

Home
Appliances

Middle East Catalogue

TEKA
TECHNIK & KÜCHE

HOME APPLIANCES

Our company	02
Cook your way to life	04
Brand values	06
Design	10
Product Editions	12
Our Range	
Ovens	14
Microwaves	46
Coffee machine	64
Hobs	70
Free Standing Cookers	110
Hoods	116
Cold Line	148
Dishwashers	164
Laundry	174





TEKA | GROUP

*Thousands of solutions.
Millions of moments.*

Teka Group comprehends different worldwide leading brands, such as Teka, Küppersbusch, Intra or Thor. The group, with more than 140 years of history, has become an international example of household appliances manufacturing. As of today, Teka owns 15 factories and 4.000 workers around the world, with presence in more than 120 countries in five continents.

TEKA

Küppersbusch
FÜR KÜCHEN MIT STIL

intra
SCANDINAVIAN DESIGN

THOR



Cook your **way to life**

The kitchen is the heart of your home. In Teka, we design appliances to be the soul of your kitchen. Because it is here where life happens, where some of the best moments of our lives take place.

The kitchen is more for us than just a place where meals are made. It is a place to laugh, to dream, to contribute, to talk, to make decisions, to share news, to make life plans and, in the end, a place to live unforgettable moments. For all these reasons, we design and manufacture appliances to bring solutions and real innovation to the kitchen, solutions that fit your lifestyle and are in harmony with your home. Every day we work to better understand your needs and bring new solutions to help you out by finding new possibilities in the kitchen. Our trademark, born in Germany, relies on quality, technology and innovation. Teka products are known worldwide for their reliability, efficiency and precision. Today, after almost 100 years of history, Teka keeps working exhaustively to give all of its products the best functionalities and design to reach excellence in every step. Our values, deeply rooted in our company, are clear: Honesty, Generosity and Originality.

This means we work for you and we are always by your side, helping you to solve your everyday problems with world class quality solutions. Customer satisfaction is our main concern. We have strived from our very beginning towards best quality products, the most modern and original designs, and the best innovations at a fair price.



A scenic landscape at sunset. The sun is low on the horizon, casting a warm, golden glow over the scene. The sun's rays are visible, creating a lens flare effect. In the foreground, a person is sitting on a blue, textured mat, with their legs and feet visible. The ground is covered in low-lying vegetation and rocks. In the background, there are rolling hills and mountains under a clear sky.

Inspiring **meaningful moments**

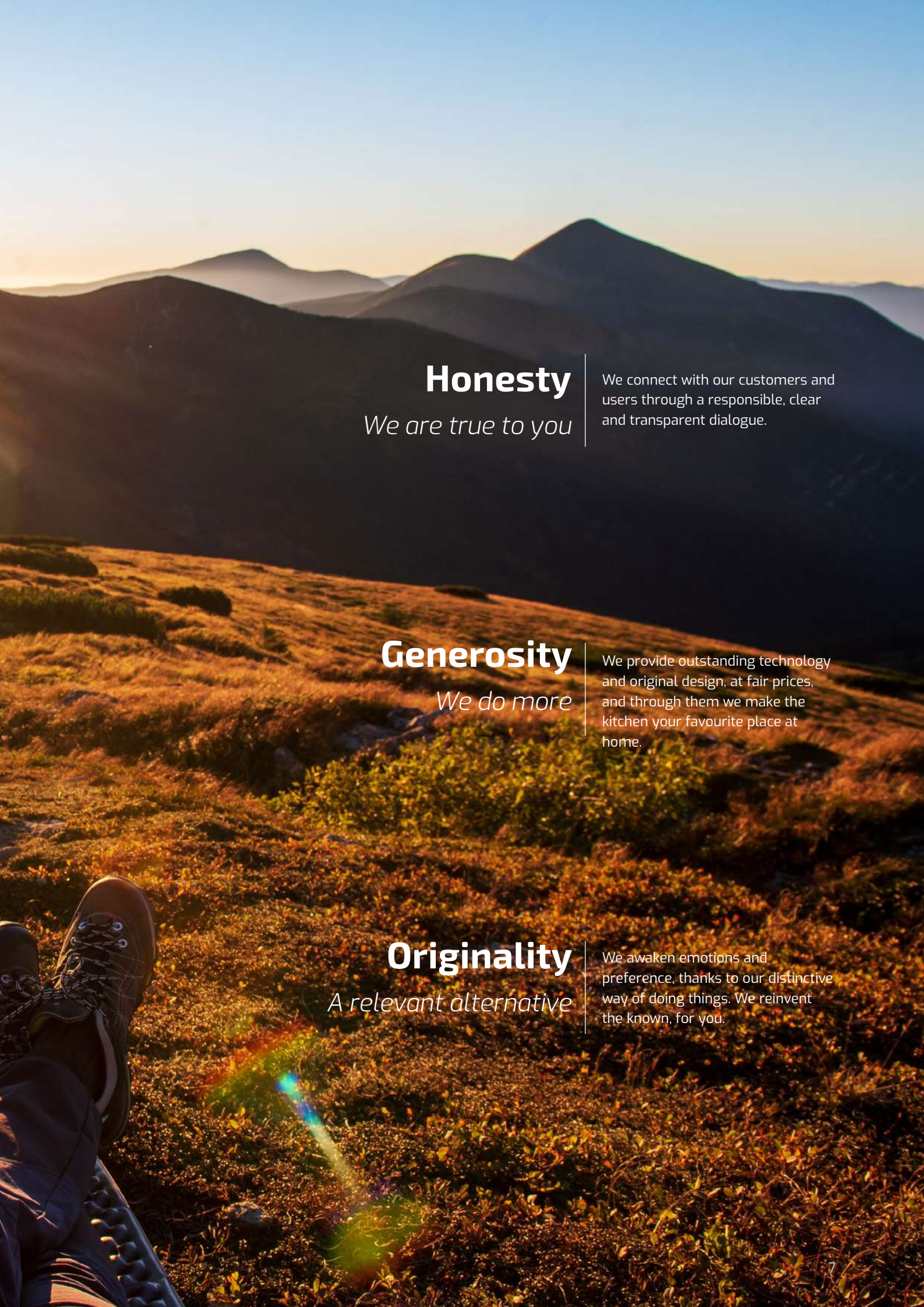

Honesty

We are true to you

We connect with our customers and users through a responsible, clear and transparent dialogue.

Generosity

We do more

We provide outstanding technology and original design, at fair prices, and through them we make the kitchen your favourite place at home.

Originality

A relevant alternative

We awaken emotions and preference, thanks to our distinctive way of doing things. We reinvent the known, for you.

Made for your
lifestyle





We work to make your life easier, and to design products to be the perfect complement for your kitchen.

As we truly believe that the kitchen is the heart of our homes and our lives, we create products to be in harmony with your lifestyle. To help you choose the products that better suit you, we have created three different lifestyle product categories, to facilitate the search and comparison of products, and so that you can find the one that is right for you.

MAESTRO

The **MAESTRO** range products are designed for the most demanding ones. For those in love with the kitchen, who want the latest innovations, and who enjoy high-quality cuisine at home. With this range, you will get the most out of your gastronomic skills, and you will have at your disposal the best options for your appliances.

TOTAL

The **TOTAL** range is made for those who love to cook and do not want to give up having the best options at their fingertips.

An option designed for those who want the best results with the minimum consumption.

EASY

The **EASY** range is designed for those looking for convenient, functional appliances, with good performance and at a fair price. Simple but smart solutions affordable for everyone.

Enter the **Infinity Design**

Infinity is the way we understand design and how we apply it to our product range.

In Teka we integrate our Infinity Design concepts at every step along the way to create our range of products and kitchen solutions.

Infinity Design was born based on one core idea: "everybody deserves great design." Teka takes the concept to reality and turns everyday actions in the kitchen into unique experiences.

Teka Infinity design is based on the following principles:



DARING TO BE UNIQUE

As we dare to be different and set ourselves
apart from the mainstream.



INTUITIVE WITH SIMPLICITY

Easy-to-use and intuitive displays are a must
for our kitchen articles, where plainness and
handiness work together with style. This is Teka
INFINITY DESIGN.



MINIMALISM WITH PERFORMANCE

We use pure, clean shapes and lines to show off
the best of our products.



STYLISH WITH ATTITUDE

The use of outstanding accent colours, new
materials and high-quality finishing reveals the
attitude behind our products.

Pure lines and essential forms







STEA



Ovens

The best moments are born
in the kitchen



WORLDWIDE **NOVELTY**

Infinity | G1 Edition

VELVET FEELING, A TOUCH LIKE NO OTHER

Feel the difference and get an exclusive composition out of your kitchen.

With its unique black matt finishing, copper details, and advanced cooking functions, our new Infinity | G1 Edition 60cm Oven promises an experience at the next level.



Black matt finishing

And a velvet touch that won't stop surprising you time after time.



340 °C

Temperature

Ideal temperature for the perfect homemade pizza with its MaestroPizza function.



Discover the complete edition

Get the most out of your Infinity | G1 Edition 60cm oven, by matching it with the rest of the products of the edition.



SCAN AND DISCOVER

WORLDWIDE **NOVELTY**

SteakMaster oven

WELCOME MEAT LOVERS



S T E A K  M A S T E R

The first and only oven capable of cooking a perfect steak at home is here.

High temperatures that reach up to 700°C, along with the cast iron grid will give your meat cuts a unique grill flavour in just a few minutes.

Choose to cook manually to manage every step and how you would like your steak cooked, or simply select one of its 20 automatic programs: SteakMaster is designed to temper the meat, keep it juicy, and seal the cut, recreating the heat process of a professional grill.

Additionally, the SteakMaster is a pyrolytic multifunction oven capable of cooking all the recipes you want.



Temperature

Grill that reaches up to 700°C for a perfect finish.



Automatic Programs

20 automatic programs, special for each meat cut.



Cast Iron Grid

The perfect grill for meat at its best.



Pyrolytic Oven

Hygiene with the power of heat.



WORLDWIDE **NOVELTY**

MaestroPizza oven

BECOME A PIZZA LEGEND



The perfect oven to cook an authentic Neapolitan pizza at home has arrived, and it reaches up to 340°C in the cavity for an epic result.

The combination of high temperature and cooking speed, along with the pizza stone, results on a crunchy crust and savouring ingredients. With MaestroPizza you'll be able to prepare 10 pizzas in only 30 minutes, getting always the same result: perfect.

Besides, MaestroPizza is a last generation multifunction oven, with dual cleaning system: Pyrolysis and HydroClean.



Temperature

The perfect temperature to cook pizza with epic results.



Pizza Stone

For a crunchy finish, as in a wood oven.



Speed

Your pizza ready in only 3 minutes.



Pizza Peel

Everything you need to cook like a real chef.

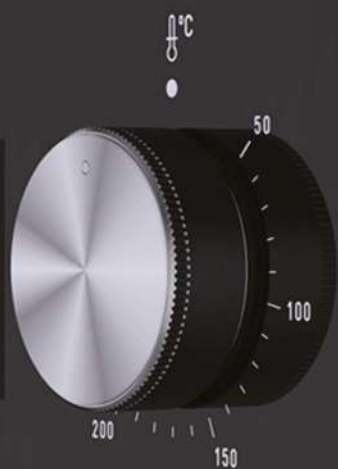

This multifunction oven's special AirFry function gets an oil-free crunchy finish, offering pleasure without guilt.

The AirFry function, along with the oven's FryMaster Box and its SurroundTemp technology, which distributes the heat evenly through the cavity, will give you the crunchy finish that you love, without the need to turn the food over, or using oil.

All of this in a multifunction oven, capable of preparing any recipes you want, with a 70 net litres capacity, more than +30% compared to other ovens*.



AirFry function

Special AirFry function for oil-free crunchy finish.



FryMaster Box

Die cut tray that allows an even heat circulation, without turning over the food.



Surroundtemp

An additional rear electrical resistance distributes the heat evenly through the cavity.



Oil-free

Ideal for French fries, nuggets and chicken wings.

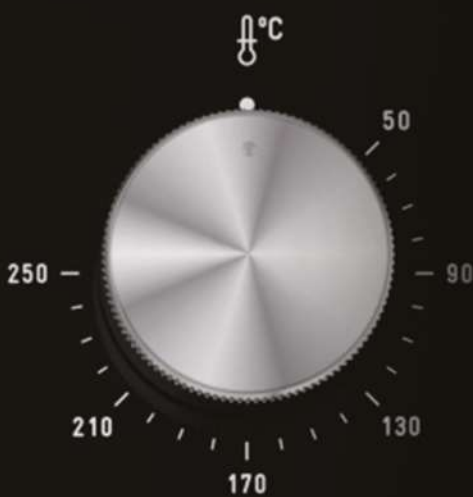

Safety first

In Teka we know that, even with the comfort and convenience that our products bring into your life, safety comes first for you and your family.

For us, safety is non-negotiable as well, and we provide with several options to take care of you and your loved ones.



Door lock

Block the door for as long as you need, for maximum safety. This safety system is available in all pyrolytic ovens.



Child lock

Block the control panel to keep the oven functioning on check.

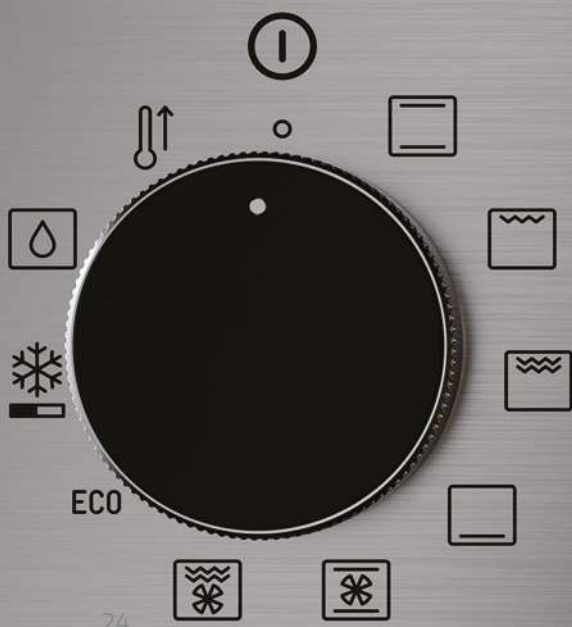



SoftClose

Say goodbye to annoying noises thanks to the soft open and close door of the oven. An extra of durability and security (your fingers will be happy about it too).



Cool front

We go beyond regulation with the minimal door temperature thanks to up to 4 removable glasses on door.



Ovens

The kitchen is where
life happens

		MAESTRO					
		TFT 4"			TOUCH CONTROL DISPLAY LED		
MULTIFUNCTION	HYDROCLEAN PRO						
		STEAKMASTER	HLB 860	HLB 8600 BK	INFINITY GI EDITION	HLB 8510 P BK	HLB 830
							
		HLB 8600 ST	HLB 8600 WH		HLB 850	HLF 940	
	HYDROCLEAN ECO						
CONVENTIONAL	HYDROCLEAN ECO						
GAS							
STEAM	MULTI FUNCTION						
					HLB 8550 SC BK		

MAESTRO

Domestic appliances for those who like going one step further. For those who will not settle for being like the rest.

TOTAL

Designed for those who demand everything of their appliances, for everyone in the house. Maximum effectiveness in any situation.

EASY

For those who prefer no complications in the kitchen without denying themselves an appliance that gives so much while asking for so little in return.

TOTAL		EASY
TOUCH CONTROL DISPLAY LED	MECHANICAL	MECHANICAL



HSB 646 55 AIRFRY



H5F 900

HSB 615



HBB 605



HBB 535



HBB 435



H5F 924 G

H5F 930 G BK

H5F 930 G



HGS 740



Ref. 11100057

NEW

MAESTRO INFINITY | G1 EDITION



- Infinity G1 special edition
- Designed in Italy by Giugiaro Italdesign
- Multifunction SurroundTemp oven
- Up to 340°C in cavity for perfect pizza finish
- Temperature range for traditional recipes: 50-250°
- Exclusive matte black finishing
- 8 cooking functions
- Pyrolysis self-cleaning system and automatic HydroClean system
- Touch control display with knobs
- Electronic timer (Delay/Start function)
- Chrome supports with 5 cooking levels
- Removable quadruple glazed door
- Automatic disconnection security system
- SoftClose system
- Children safety lock
- Manual quick preheating
- Anti-tip deep tray, baking tray and reinforced grid
- Special pizza stone included
- Capacity (gross/net): 71 /70 litres

COLOR

 **Black Matt**

PRODUCT DIMENSIONS

Height 595mm **Width** 595mm **Depth** 537+22mm



Ref. 11100055

NEW

MAESTRO STEAKMASTER



- SteakMaster Oven
- Powerfull SteakGrill (700°C)
- SurroundTemp Multifunction oven
- 12 cooking functions
- DualClean cleaning system: Pyrolytic selfcleaning (3 levels) + HydroClean® PRO
- Enamel Slippery
- A+ Energy class: up to 20% less consumption
- Capacity, gross/net: 71/63 litres
- TFT 4" true color Touch control
- LED illuminated knobs
- 20 automatic programs for meat
- Personal cook assistant: 20 international recipes
- Automatic Express preheating
- SlowCook: low temperature cooking
- Children safety block, timer and door
- Automatic disconnection security system
- 4 removable glazed door
- SoftClose system
- Full glass inner door
- 2 Plus-Extension telescopic guide, 5 cooking levels
- Special cast iron grid for Steaks
- Tangential ventilation Plus with 2 speeds

COLOR

 **Black Glass**

FRAME Stainless steel

PRODUCT DIMENSIONS

Height 595mm **Width** 595mm **Depth** 559mm



Ref. 111200002

NEW**MAESTRO HLB 8550 SC BK STEAMCHEF**

- Multifunction SurroundTemp Steam oven
- 12 cooking functions
- Automatic HydroClean system
- Touch control display with knobs
- Electronic timer
- Chrome supports with 5 cooking levels
- Easy slide telescopic guides
- Removable triple glazed door
- Automatic disconnection security system
- SoftClose system
- Automatic quick preheating
- Anti-tip deep tray
- Baking tray and reinforced grid included
- Capacity (gross/net): 71 / 70 litres

COLOR

 **Black Glass**

FRAME Infinity glass

PRODUCT DIMENSIONS

Height 595mm **Width** 595mm **Depth** 537+22 mm



Ref. 41560090

MAESTRO HLB 860

- Multifunction SurroundTemp
- 12 Cooking functions
- HydroClean® PRO cleaning system
- A+ Energy class: up to 20% less consumption
- Capacity, gross/net: 71/70 litres
- Touch Control panel with TFT 4"
- LED illuminated knobs
- Personal Cook assistant: 20 programmed recipes
- Automatic Express preheating
- SlowCook function: low temperature cooking
- Pizza, ferment, defrosting & ECO functions
- Children safety block
- Automatic disconnection security system
- Tripple removable glazed door
- SoftClose door
- Full glass inner door
- 1 Plus-Extension telescopic guide easy slide
- Tangential ventilation
- Anti-tip deep tray and reinforced grid
- Drop down maxi grill

COLOR

 **Black Glass**

FRAME Stainless steel

PRODUCT DIMENSIONS

Height 595mm **Width** 595mm **Depth** 559mm



Ref. 111000010

MAESTRO HLB 8600 BK



- Urban Colors Edition
- Multifunction SurroundTemp
- 12 Cooking functions
- Teka HydroClean@PRO cleaning system
- A+ Energy class: up to 20% less consumption
- Capacity, gross/net: 71/70 litres
- True colour TFT 4 display with digital timer
- Personal cooking assistant (20 recipes)
- SlowCook function: low temperature cooking
- Automatic temperature and time suggestion for each function
- Quick heating
- Children safety block
- Automatic disconnection security system
- Triple glazed door
- SoftClose system
- 1 Plus-Extension telescopic guide, 5 cooking levels
- Deep enamelled tray and reinforced grid
- Tangential ventilation

COLOR

 Black glass

FRAME Infinity glass

PRODUCT DIMENSIONS

Height 595mm **Width** 595mm **Depth** 559mm



Ref. 111000012

MAESTRO HLB 8600 WH



- Urban Colors Edition
- Multifunction SurroundTemp
- 12 Cooking functions
- Teka HydroClean@PRO cleaning system
- A+ Energy class: up to 20% less consumption
- Capacity, gross/net: 71/70 litres
- True colour TFT 4 display with digital timer
- Personal cooking assistant (20 recipes)
- SlowCook function: low temperature cooking
- Automatic temperature and time suggestion for each function
- Quick heating
- Children safety block
- Automatic disconnection security system
- Triple glazed door
- SoftClose system
- 1 Plus-Extension telescopic guide, 5 cooking levels
- Deep enamelled tray and reinforced grid
- Tangential ventilation

COLOR

 White Glass

FRAME Infinity glass

PRODUCT DIMENSIONS

Height 595mm **Width** 595mm **Depth** 559mm



Ref. 111000011

MAESTRO HLB 8600 ST



- Urban Colors Edition
- Multifunction SurroundTemp
- 12 Cooking functions
- Teka HydroClean®PRO cleaning system
- A+ Energy class: up to 20% less consumption
- Capacity, gross/net: 71/70 litres
- True colour TFT 4 display with digital timer
- Personal cooking assistant (20 recipes)
- SlowCook function: low temperature cooking
- Automatic temperature and time suggestion for each function
- Quick heating
- Children safety block
- Automatic disconnection security system
- Triple glazed door
- SoftClose system
- 1 Plus-Extension telescopic guide, 5 cooking levels
- Deep enamelled tray and reinforced grid
- Tangential ventilation

COLOR

 Stone Grey Glass

FRAME Infinity glass

PRODUCT DIMENSIONS

Height 595mm **Width** 595mm **Depth** 559mm



Ref. 111000046

NEW

MAESTRO HLB 8510 P BK MAESTRO PIZZA



- Maestropizza oven
- Urban Colors Edition
- Multifunction SurroundTemp oven
- 8 cooking functions
- Up to 340°C in cavity for perfect pizza finish
- Temperature range for traditional recipes: 50-250°
- Capacity (gross/net): 71/70 litres
- Pyrolysis self-cleaning system and automatic HydroClean system
- Touch control display with knobs
- Electronic timer (Delay/Start function)
- Chrome supports with 5 cooking levels
- 1 Plus Extension Telescopic guides
- Removable quadruple glazed door
- SoftClose system
- Automatic disconnection security system
- Children safety lock
- Manual quick heating
- Anti-tip deep tray, baking tray and reinforced grid
- Special pizza stone included

COLOR

 Black Glass

FRAME Infinity glass

PRODUCT DIMENSIONS

Height 595mm **Width** 595mm **Depth** 559mm



Ref. 41560290

MAESTRO HLB 850



- Multifunction SurroundTemp
- 9 Cooking functions
- HydroClean® PRO cleaning system
- A+ Energy class: up to 20% less consumption
- Capacity, gross/net: 71/70 litres
- Touch Control panel with LED display
- ECO & defrosting functions
- Children safety block
- Triple glazed door
- SoftClose door
- Full glass inner door
- 1 Plus Extension telescopic guide easy slide
- Anti-tip deep tray and reinforced grid
- Stainless steel fix knobs with black cover
- Drop down maxi grill
- Cooling fan
- Dynamic ventilation
- Optional Multicook and cast aluminium tray

COLOR

 Black Glass

FRAME Stainless steel

PRODUCT DIMENSIONS

Height 595mm **Width** 595mm **Depth** 559mm



Ref. 41560060

MAESTRO HLB 830



- Multifunction
- 6 Cooking functions
- HydroClean® PRO cleaning system
- A+ Energy class: up to 20% less consumption
- Capacity, gross/net: 71/70 litres
- Touch Control panel with LED display
- Express preheating
- ECO & defrosting functions
- Children safety block
- Double removable glazed door
- Fully glass inner doors
- 1 telescopic guide easy slide
- Dynamic ventilation
- Optional Multicook and cast aluminium tray
- Anti-tip deep tray and cooking grid

COLOR

 Black Glass

FRAME Stainless steel

PRODUCT DIMENSIONS

Height 595mm **Width** 595mm **Depth** 559mm



Ref. 111010024

NEW**TOTAL HSB 646 SS AIRFRY**

- AirFry oven
- Multifunction SurroundTemp oven
- 9 cooking functions
- Special FryMaster Box to cook without oil
- Automatic HydroClean system
- Capacity (gross/net): 71/70 litres
- Touch control display with knobs
- Electronic timer (Delay/Start function)
- Chrome supports with 5 cooking levels
- 1 Plus Extension Telescopic guides
- Removable double glazed door
- Children safety lock
- Manual quick preheating
- Anti-tip deep and baking trays
- A+ Energy class

COLOR

 **Stainless Steel**

FRAME Stainless steel

PRODUCT DIMENSIONS

Height 595mm **Width** 595mm **Depth** 559mm



Ref. 41560120

TOTAL HSB 615

- Multifunction
- 6 Cooking functions
- HydroClean® ECO cleaning system
- A+ Energy class: up to 20% less consumption
- Capacity, gross/net: 71/70 litres
- Minute Minder
- Express preheating function
- ECO and defrosting functions
- Double removable glazed door
- Full glass inner door
- 1 plus-extension telescopic guide easy slide
- Dynamic ventilation
- Anti-tip deep & baking trays and cooking grid
- Optional Multicook and cast aluminium tray

COLOR

 **Stainless Steel**

FRAME Stainless steel

PRODUCT DIMENSIONS

Height 595mm **Width** 595mm **Depth** 559mm



Ref. 41560050

EASY HBB 605



- Multifunction
- 6 Cooking functions
- HydroClean® ECO cleaning system
- A Energy class
- Capacity, gross/net: 71/70 litres
- Minute minder
- Express preheating function
- ECO and defrosting functions
- Double removable glazed door
- Full glass inner door
- Dynamic ventilation
- Anti-tip deep & baking tray and cooking grid
- Dynamic ventilation
- Optional Multicook tray

COLOR

 Stainless Steel

FRAME Frameless

PRODUCT DIMENSIONS

Height 595mm **Width** 595mm **Depth** 559mm



Ref. 41560040

EASY HBB 535



- Conventional
- 3 Cooking functions
- HydroClean® ECO cleaning system
- A Energy class
- Capacity, gross/net: 77/76 litres
- Minute minder
- Double removable glazed door
- Full glass inner door
- Dynamic ventilation
- Anti-tip deep tray and cooking grid
- Optional Multicook tray

COLOR

 Stainless Steel

FRAME Frameless

PRODUCT DIMENSIONS

Height 595mm **Width** 595mm **Depth** 559mm



Ref. 41560010

EASY HBB 435



- Conventional
- 3 Cooking functions
- Enamel Slippery
- A Energy class
- Capacity, gross/net: 75/72 litres
- Double removable glazed door
- Full glass inner door
- Dynamic ventilation
- Anti-tip deep tray cooking grid
- Optional Multicook tray

COLOR

 Stainless Steel

FRAME Frameless

PRODUCT DIMENSIONS

Height 595mm **Width** 595mm **Depth** 559mm





Ref. 41592226

MAESTRO HLF 940



- Multifunction SurroundTemp
- 9 Cooking functions
- Hydroclean® PRO cleaning system
- A Energy class
- Capacity, gross/net: 91/77 litres
- 1 Plus + 1 Full Extension telescopic guides
- Children safety block
- Dynamic ventilation
- Anti-tip deep & baking tray and cooking grid
- Touch Control panel
- Tripple glazed door
- Full glass inner door
- Drop down maxi grill
- Automatic disconnection security system

COLOR

 **Black Glass**

FRAME Stainless steel

PRODUCT DIMENSIONS

Height 480mm **Width** 890mm **Depth** 560mm



Ref. 41592225

TOTAL HSF 900



- Hydroclean® ECO cleaning system
- 7 Cooking functions
- A Energy class
- Capacity, gross/net: 91/77
- Tangential ventilation
- Triple glazed door
- Anti-tip deep & baking tray and cooking grid
- Minute minder
- Drop down maxi grill
- Full glass inner door

COLOR

 **Stainless Steel**

FRAME Stainless steel

PRODUCT DIMENSIONS

Height 480mm **Width** 890mm **Depth** 560mm



Ref. 41596124

TOTAL HSF 930 G

- Multifunction gas oven with gas grill
- 4 Cooking functions
- B Energy class
- Capacity Gross/Net: 88/64 litres
- Black Knob timer with stop programmer
- Double glazed door
- Full glass inner door
- Chromed guides, 5 cooking levels
- Automatic gas oven ignition
- Deep tray and cooking grid
- Tangential ventilation
- Gas typology: LPG (butane/propane)
- Nozzles to natural gas

COLOR

 **Stainless Steel**

FRAME Stainless steel

PRODUCT DIMENSIONS

Height 595mm **Width** 898mm **Depth** 549mm



Ref. 111110000

NEW**TOTAL HSF 930 G BK**

- Multifunction gas oven with gas grill
- 4 cooking functions
- B Energy class
- Capacity (gross/net): 88/64 litres
- Mechanical control knobs
- Mechanical timer
- Chrome supports with 5 cooking levels
- Removable double glazed door
- Automatic disconnection security system
- 1 Anti-tip deep tray

COLOR

 **Black**

FRAME Black

PRODUCT DIMENSIONS

Height 595mm **Width** 898mm **Depth** 549mm



Ref. 41596123

TOTAL HSF 924 G



- Multifunction gas oven with electric grill
- 5 Cooking functions
- B Energy class
- Capacity Gross/Net: 88/69 litres
- Black Knob timer with stop programmer
- Double glazed door
- Full glass inner door
- Chromed guides, 5 cooking levels
- Automatic gas oven ignition
- Deep tray and cooking grid
- Tangential ventilation
- Gas typology: LPG (butane/propane)
- Nozzles to natural gas

COLOR

 Stainless Steel

FRAME Stainless steel

PRODUCT DIMENSIONS

Height 595mm **Width** 898mm **Depth** 549mm



Ref. 41597404

NEW

EASY HGS 740 G



- Multifunction gas oven with gas grill
- B Energy class
- Capacity Gross/Net: 56.3/45.6 litres
- 4 cooking functions
- Mechanical timer with stop programmer
- Children safety block
- Double glazed door
- Full glass inner door
- Side catalytic panels
- Deep tray and cooking grid
- Tangential ventilation
- Nozzels to LPG gas

COLOR

 Stainless Steel

FRAME Frameless

PRODUCT DIMENSIONS

Height 595mm **Width** 595mm **Depth** 562mm



Ref. 111600003

MAESTRO CP 150 GS

- Urban Colors Edition
 - Plate warmer
 - Temperature range: 30°-80°
 - 6 plates setting: 6 dinner plates (24 cm), 6 deep plates (10 cm), and 3 serving platters (17, 19 and 32 cm) or 20 dinner plates (28 cm) or 40 tea cups or 80 coffee cups.
 - Pull out telescopic drawer
 - Push-pull opening system
 - Anti-sliding base
- Frontal Glass not included:

Refer to page no 41 for below colors

- | | |
|---|--|
| <input checked="" type="checkbox"/> Black Glass | <input checked="" type="checkbox"/> Stone Grey Glass |
| <input checked="" type="checkbox"/> Black Matt | <input type="checkbox"/> White Glass |

COLOR

FRAME Infinity Glass

PRODUCT DIMENSIONS

Height 140mm **Width** 595mm **Depth** 559mm





A distinguished way to serve your delicious meals

Turn every meal into comfort food, keeping not only the heat, but also the texture and aroma you wanted when you conceived the recipe. Make the whole cooking and eating experience perfect by making sure that the plating is the best possible as well.





Ref. 111890002

MAESTRO KIT VS/CP COLOR BK

- Frontal Panel
- Urban Colors Edition

COLOR

 Black Glass



Ref. 111890003

MAESTRO KIT VS/CP COLOR WH

- Frontal Panel
- Urban Colors Edition

COLOR

 White Glass



Ref. 111890004

MAESTRO KIT VS/CP COLOR ST

- Frontal Panel
- Urban Colors Edition

COLOR

 Stone Grey Glass



Ref. 111490016

NEW

MAESTRO KIT VS/CP MB INFINITY G1

- Frontal Panel
- Infinity G1 Edition

COLOR

 Matt Black

MODEL	MaestroPizza HLB 85, Infinity G1	SteakMaster	HLB 860	HLB 8600	MaestroPizza HLB 8510 P BK
INNER CAVITY DIMENSIONS					
Height (mm)	364	364	364	364	364
Width (mm)	475	475	475	475	475
Depth (mm)	402	402	402	402	402
Volume Net (L)	70	63	70	70	70
ELECTRICAL FEATURES					
Maximum Nominal Power (W)	3.552	3.518	3.215	3.215	3.552
Bottom Heating Element (W)	1.050	1.050	1.150	1.150	1.050
Grill (W)	1.400	2.400	1.400	1.400	1.400
Maxigrill (W)	2.450	3.540	2.500	2.500	2.450
Turbo (W)	2.000	2.000	2.000	2.000	2.000
Multifunction motor (W)	25	25	22	22	25
Inner Light	25	2x25	25	25	25
Cooling fan motor (W)	30	30	18	18	30
Cable connection length (cm)	150	150	150	150	190
SAFETY SYSTEMS					
Automatic disconnection security system	✓	✓	✓	✓	✓
Children safety	✓	✓	✓	✓	✓
Grill protection	✓	✓	✓	✓	✓
Full glazed door	4	4	3	3	4
CLEANING SYSTEMS					
Hydroclean ECO	-	-	-	-	-
Hydroclean PRO	✓	✓	✓	✓	✓
Pyrolytic	✓	✓	-	-	✓
Crystal Clean Enamel	✓	✓	✓	✓	✓
ENERGY EFFICIENCY					
Energy Efficiency Class	A+	A	A+	A+	A+
MODEL					
	HLB 850	HLB 830	HSB 646 SS	HSB 615	HLB 8550 SC BK
INNER CAVITY DIMENSIONS					
Height (mm)	364	364	364	364	364
Width (mm)	475	475	475	475	475
Depth (mm)	402	402	402	402	402
Volume Net (L)	70	70	70	70	70
ELECTRICAL FEATURES					
Maximum Nominal Power (W)	3.215	2.593	3.215	2.615	3215
Bottom Heating Element (W)	1.150	1.150	1.150	1.150	1150
Grill (W)	1.400	1.400	1.400	1.400	1400
Maxigrill (W)	2.500	-	2.500	-	2500
Turbo (W)	2.000	-	2.000	-	2000
Multifunction motor (W)	22	22	22	22	22
Inner Light	25	25	25	25	25
Cooling fan motor (W)	18	18	18	18	18
Cable connection length (cm)	150	110	150	110	110
SAFETY SYSTEMS					
Automatic disconnection security system	-	-	-	-	V
Children safety	✓	✓	-	-	-
Grill protection	✓	✓	✓	✓	V
Full glazed door	3	2	2	2	3
CLEANING SYSTEMS					
Hydroclean ECO	-	-	-	✓	-
Hydroclean PRO	✓	✓	✓	-	V
Pyrolytic	-	-	-	-	-
Crystal Clean Enamel	✓	✓	✓	✓	V
ENERGY EFFICIENCY					
Energy Efficiency Class	A+	A+	A+	A+	A+

MODEL	HBB 605	HBB 535	HBB 435	HLF 940	HSF 900
INNER CAVITY DIMENSIONS					
Height (mm)	364	364	364	318	318
Width (mm)	475	475	446	639	639
Depth (mm)	402	441	441	380	380
Volume Net (L)	70	76	72	77	77
ELECTRICAL FEATURES					
Maximum Nominal Power (W)	2.615	2.593	2.593	3.553	2.848
Bottom Heating Element (W)	1.150	1.150	1.150	1.055	1.055
Grill (W)	1.400	1.400	1.400	1.700	1.700
Maxigrill (W)	-	-	-	2.750	2.750
Turbo (W)	-	-	-	2.400	-
Multifunction motor (W)	22	-	-	30	30
Inner Light	25	25	25	25	25
Cooling fan motor (W)	18	18	18	18	18
Cable connection length (cm)	110	110	110	110	110
SAFETY SYSTEMS					
Automatic disconnection security system	-	-	-	✓	-
Children safety	-	-	-	✓	-
Grill protection	✓	✓	✓	✓	✓
Full glazed door	2	2	2	3	2
CLEANING SYSTEMS					
Hydroclean ECO	✓	✓	-	-	✓
Hydroclean PRO	-	-	-	✓	-
Pyrolytic	-	-	-	-	-
Crystal Clean Enamel	✓	✓	✓	✓	✓
ENERGY EFFICIENCY					
Energy Efficiency Class	A	A	A	A	A

MODEL	HSF 924 G	HSF 930 G	HGS 740
INNER CAVITY DIMENSIONS			
Height (mm)	308	280	320
Width (mm)	615	615	419
Depth (mm)	388	388	400
Volume Net (L)	69	64	45.6
ELECTRICAL FEATURES			
Maximum Nominal Power (W)	1.998	1.531	70
Bottom Heating Element (W)	4.000	4.000	2.400
Grill (W)	19	-	1.800
Maxigrill (W)	-	-	-
Turbo (W)	-	-	2.700
Multifunction motor (W)	30	30	30
Inner Light	25	25	25
Cooling fan motor (W)	18	18	18
Cable connection length (cm)	110	110	-
SAFETY SYSTEMS			
Automatic disconnection security system	-	-	-
Children safety	-	-	-
Grill protection	✓	✓	-
Full glazed door	2	2	2
CLEANING SYSTEMS			
Hydroclean ECO	-	-	-
Hydroclean PRO	-	-	-
Pyrolytic	-	-	-
Crystal Clean Enamel	✓	✓	✓
ENERGY EFFICIENCY			
Energy Efficiency Class	B	B	B

OVENS

INSTALLATION DIAGRAM

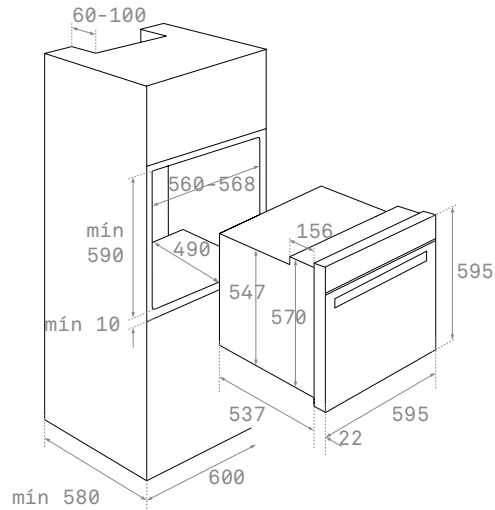

INFINITY G1 · STEAKMASTER · HLB 8510 · HLB 860 · HLB 8600 · HLB 850
 HLB 8550 SC BK · HLB 830 · HSB 646 SS · HSB 615 · HBB 605 · HBB 535 · HBB 435

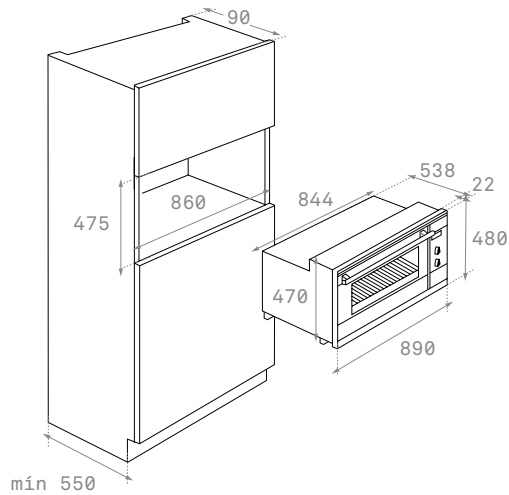

HLF 940 · HSF 900

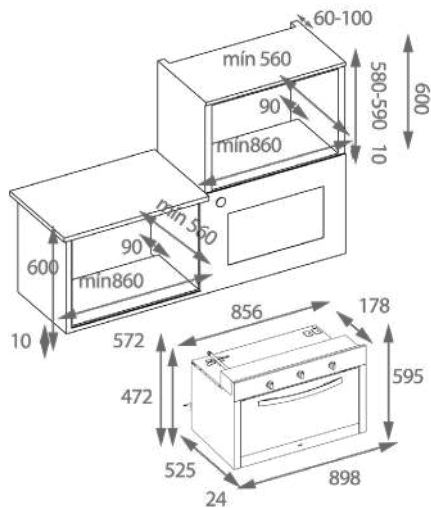

HSF 924 G · HSF 930 G

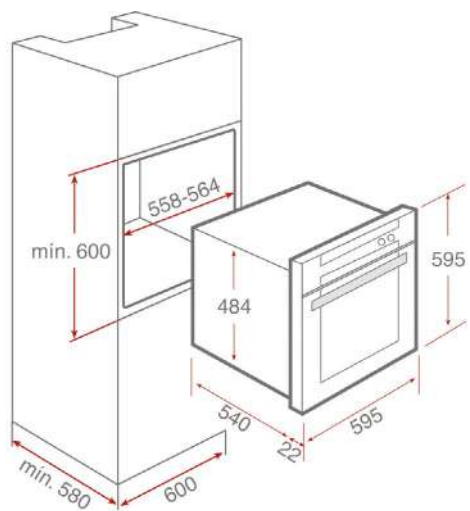

HGS 740 G

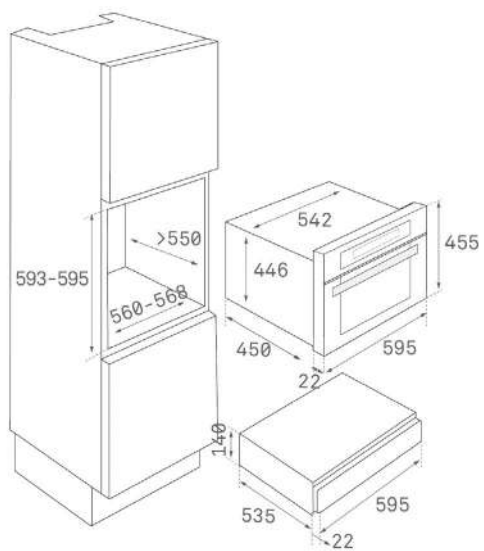

CP 150 GS



TEKA



Microwaves

The kitchen is where family memories are homemade



WORLDWIDE **NOVELTY**

Infinity | G1 Edition

THE BEST LOOKING CONVENIENCE

The microwave, reinvented.

Convenience and fast cooking solutions will be only part of the advantages of our new Infinity | G1 Edition Microwave Oven, which will fulfill all of these cooking needs, in such a stylish way, rarely seen in a microwave oven.



Black matt finishing

For an exclusive look. Soft touch and attractive design.



Convenient solution

Your quick cooking needs, solved in the most elegant and convenient way possible.



Discover the complete edition

Get the most out of your Infinity | G1 Edition Microwave Oven, by matching it with the rest of the products of the edition.

INFINITY G1

19:24

INFINITY G1

TEKA



19:24



SCAN AND
DISCOVER

Cooking meals to share **was never so fast and easy**

Ceramic base

Don't get another hot-but-cold dish thanks to our homogeneous heat system. Waves distribution comes from the lower ceramic base with no need to use turntable plates.

Our microwaves have wide cooking surfaces to use bigger plates, and a completely flat cavity, easier to clean and to reach any part of it where food stains may remain. Great efficiency comes included too.

Crunch plate

You can do a potato omelette without turning it upside down. Cook a quiche or even do some crunchy French fries. You can even have crispy pizzas thanks to the plate, reaching very high temperatures to turn the borders golden brown and crusty.

Memory

With our microwaves you can select different power memories and heating times so you can repeat your favourite recipes as many times as you wish.

Easy installation





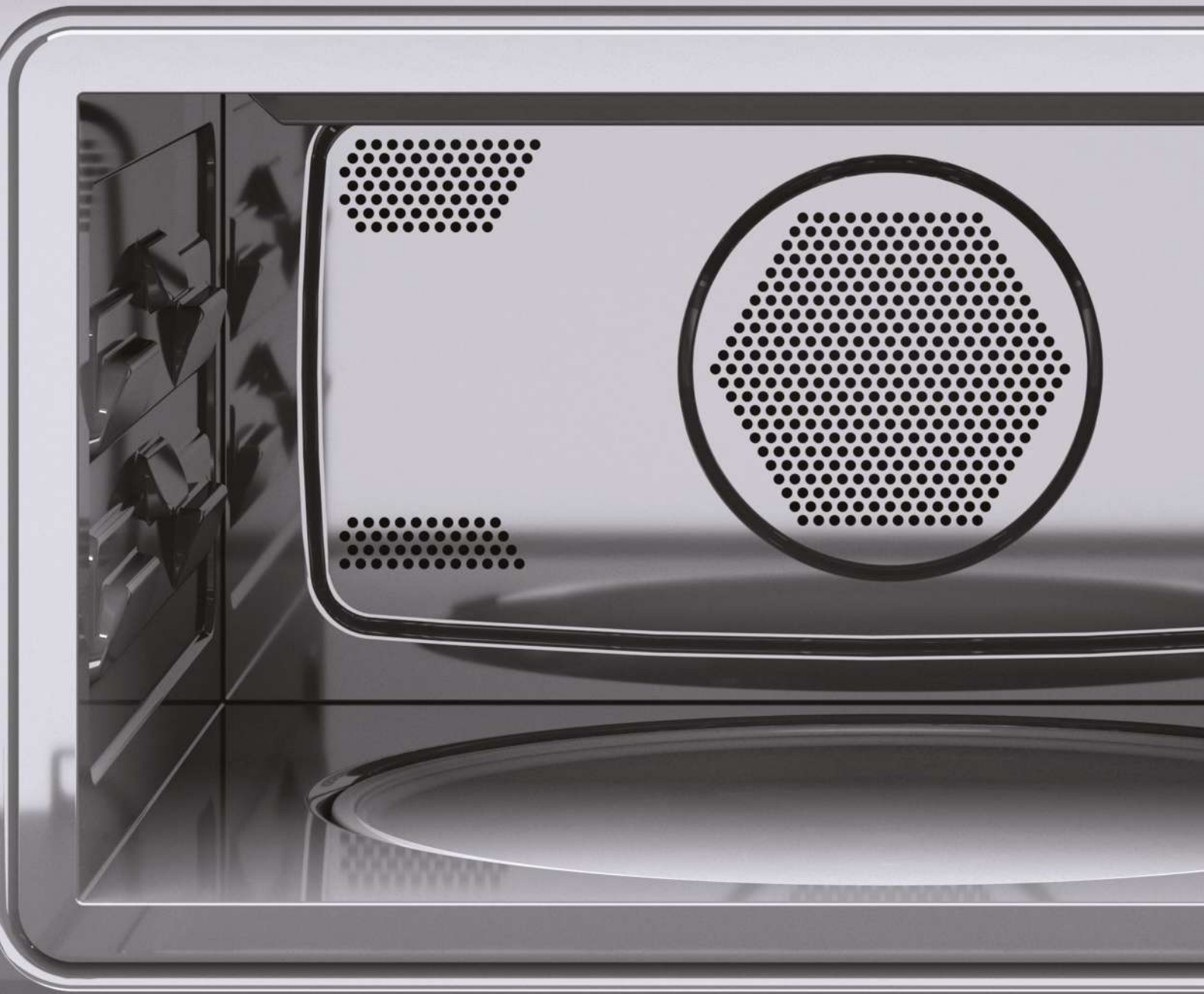







Frontal trim kit is included in the microwave for an easy installation. The frame is already fixed to the microwave oven instead of the cabinet, so the assembly process is faster, and we can get our new microwave ready in just 5 minutes and using only 4 screws.





Microwaves

Cooking is believing.

		MAESTRO			
		TFT 4"	ELECTRONIC CONTROL DIGITAL DISPLAY	TOUCH CONTROL LED DISPLAY	TOUCH CONTROL TFT WHITE DISPLAY
MULTI FUNCTION	OVEN + MICROWAVE			 <p>HLC 844 C</p>	
	MICROWAVE + GRILL	 <p>ML 8220 BIS L BK</p>	 <p>ML 8220 BIS L WH</p>	 <p>MLC 844</p>	
BUILT-IN	MICROWAVE + GRILL	 <p>ML 8220 BIS L ST</p>	 <p>ML 82 INFINITY G1</p>	 <p>MLC 8440 BK</p>	 <p>ML 820 BIS</p>
		 <p>ML 822 BIS</p>		 <p>MLC 8440 ST</p>	
	MICROWAVE				
COFFEE MACHINE		 <p>CLC 835 MC</p>	 <p>CLC 855 GM BK</p>	 <p>CLC 855 GM ST</p>	

MAESTRO

Domestic appliances for those who like going one step further. For those who will not settle for being like the rest.

TOTAL

Designed for those who demand everything of their appliances, for everyone in the house. Maximum effectiveness in any situation.

EASY

For those who prefer no complications in the kitchen without denying themselves an appliance that gives so much while asking for so little in return.

TOTAL		EASY	
TOUCH CONTROL DISPLAY LED	TOUCH CONTROL TFT DISPLAY	MECHANICAL	MECHANICAL



MS 622 BIS L



MS 620 BIS



MSC 642



MS 622 BI L



MB 620 BI



Ref. 40587602



Ref. 40584400

MAESTRO HLC 844 C



- Combi Multifunction SurroundTemp + Microwave
- HydroClean® ECO cleaning system
- Enamel Slippery
- Capacity, gross/net: 41/40 litres
- Touch Control panel with LED display
- 11 cooking functions
- Quick start 30"
- 2500 W maxigrill
- Microwave combinations Pizza & ECO functions
- Automatic defrost by time and weight
- Children safety block
- Automatic disconnection security system
- Triple removable glazed door
- Full glass inner door
- Tangential ventilation
- Anti-tip glass tray and reinforced grid
- Optional Muticook and cast aluminium tray

COLOR

■ Black Glass

FRAME Stainless steel

PRODUCT DIMENSIONS

Height 455mm Width 595mm Depth 559mm

MAESTRO MLC 844



- Microwave + Grill
- 3 Cooking functions
- Capacity, gross/net: 45/44 litres
- 1400 W grill
- 0-90 min. Timer
- Enamel Slippery
- Quick start 30"
- Chromed guide
- 5 Cooking heights
- 1 reinforced grid
- Touch Control panel with LED display
- 5 power levels, 1000 W
- Automatic disconnection security system
- Tangential ventilation
- Defrost by time and weight
- Double Glazed door

COLOR

■ Black Glass

FRAME Stainless steel

PRODUCT DIMENSIONS

Height 455mm Width 595mm Depth 559mm



Ref. 111160003

NEW

MAESTRO MLC 8440 BK



- Urban Colors Edition
- Microwave + Grill
- 3 cooking functions
- Capacity (gross/net): 45 / 44 litres
- 5 power levels + 1000 W microwave power
- 1400 W grill
- Defrost by time and weight
- Touch control display with knobs
- Electronic timer (Delay/Start function)
- Chrome supports with 5 cooking levels
- Removable double glazed door
- Automatic disconnection security system
- Reinforced grid

COLOR

Black Glass

FRAME Infinity Glass

PRODUCT DIMENSIONS

Height 455mm **Width** 595mm **Depth** 559mm



Ref. 111160004

NEW

MAESTRO MLC 8440 ST



- Urban Colors Edition
- Microwave + Grill
- 3 cooking functions
- Capacity (gross/net): 45 / 44 litres
- 5 power levels + 1000 W microwave power
- 1400 W grill
- Defrost by time and weight
- Touch control display with knobs
- Electronic timer (Delay/Start function)
- Chrome supports with 5 cooking levels
- Removable double glazed door
- Automatic disconnection security system
- Reinforced grid

COLOR

Stone Grey Glass

FRAME Infinity Glass

PRODUCT DIMENSIONS

Height 455mm **Width** 595mm **Depth** 559mm



Ref. 40586800

TOTAL MSC 642



- Microwave + grill
- 3 Cooking functions
- Capacity, gross/net: 45/44 litres
- Minute minder
- Electromechanical control panel
- 5 Power levels, 1.000 W
- 1400 W grill
- 0-60 min. Timer
- Defrost by time
- Automatic disconnection security system
- Double Glazed door
- Chromed guides
- 5 Cooking heights
- 1 reinforced grid
- Tangential ventilation

COLOR

 **Stainless Steel**

FRAME Stainless steel

PRODUCT DIMENSIONS

Height 455mm **Width** 595mm **Depth** 559mm



Ref. 112030010

NEW

MAESTRO ML 82 INFINITY G1



- Infinity G1 special edition
- Designed in Italy by Giugiaro Italdesign
- Built-in Microwave + Grill
- Exclusive matte black finishing
- Ceramic base with uniform heating
- 3 cooking functions
- 5 power levels, 850 W
- Grill power: 1200 W
- Defrost by time and weight
- Touch control display with knobs and minute minder
- Double glazed door with left opening
- Electronic door opening
- Automatic disconnection when open door
- Incandescent inner light
- Dropdown grill
- Quick start
- Capacity (gross/net): 22 /21.56 litres
- Stainless steel cavity
- Crunch plate included

COLOR

 **Black Matt**

PRODUCT DIMENSIONS

Height 390mm **Width** 595mm **Depth** 334mm



Ref. 40584300



Ref. 112030001

MAESTRO ML 822 BIS



- Microwave + Grill
- Ceramic base
- Capacity: 22 litres
- Touch Control panel with LED display
- Electronic door opening
- 5 power levels, 850 W
- 9 direct access menus
- 3 cooking functions
- Quick start 30"
- Drop down grill, 1200 W
- 0-90 min. Timer
- Automatic defrosting by time and weight
- Children safety block
- Double glazed door
- Stainless steel inner cavity
- Tangential ventilation
- Left door opening
- Browning plate and reinforced grid

COLOR

■ Black Glass

FRAME Stainless steel

PRODUCT DIMENSIONS

Height 390mm **Width** 595mm **Depth** 334mm

MAESTRO ML 8220 BIS L BK



- Urban Colors Edition
- Ceramic base microwave + grill
- Capacity: 22 litres
- Electronic glass control panel with digital display
- Dropdown grill, 1200W
- 5 power levels, 850 W out
- Stainless steel cavity
- Ceramic base with uniform heating
- Forced tangential ventilation
- Program selector and electronic functions
- Quick start 30"
- Defrost (5 programs)
- 9 direct access menus
- Browning plate and reinforced grill grid

COLOR

■ Black Glass

FRAME Infinity glass

PRODUCT DIMENSIONS

Height 390mm **Width** 595mm **Depth** 334mm



Ref. 112030000



Ref. 112030002

MAESTRO ML 8220 BIS L WH



- Urban Colors Edition
- Ceramic base microwave + grill
- Capacity: 22 litres
- Electronic glass control panel with digital display
- Dropdown grill, 1200W
- 5 power levels, 850 W out
- Stainless steel cavity
- Ceramic base with uniform heating
- Forced tangential ventilation
- Program selector and electronic functions
- Quick start 30"
- Defrost (5 programs)
- 9 direct access menus
- Browning plate and reinforced grill grid

COLOR

White Glass

FRAME Infinity Glass

PRODUCT DIMENSIONS

Height 390mm **Width** 595mm **Depth** 334mm

MAESTRO ML 8220 BIS L ST



- Urban Colors Edition
- Ceramic base microwave + grill
- Capacity: 22 litres
- Electronic glass control panel with digital display
- Dropdown grill, 1200W
- 5 power levels, 850 W out
- Stainless steel cavity
- Ceramic base with uniform heating
- Forced tangential ventilation
- Program selector and electronic functions
- Quick start 30"
- Defrost (5 programs)
- 9 direct access menus
- Browning plate and reinforced grill grid

COLOR

Stone Grey Glass

FRAME Infinity glass

PRODUCT DIMENSIONS

Height 390mm **Width** 595mm **Depth** 334mm



Ref. 40584200

MAESTRO ML 820 BIS



- Microwave + Grill
- Capacity: 20 litres
- Touch Control panel with TFT white display
- 5 power levels, 750 W
- 3 direct access menus
- Quick start 30"
- Automatic defrosting by time and weight
- Children safety block
- Double glazed door
- Quartz Grill, 1000 W
- 1 Round grid
- Left door opening
- 0-90 min. Timer
- Stainless steel inner cavity

COLOR

Black Glass

FRAME Stainless steel

PRODUCT DIMENSIONS

Height 390mm **Width** 595mm **Depth** 325mm





Ref. 40584100



Ref. 40584102

TOTAL MS 622 BIS L



- Microwave + Grill
- Ceramic base
- Capacity: 22 litres
- Touch Control panel with LED display
- Electronic door opening
- 5 power levels, 850 W
- 2 direct access menus
- 3 cooking functions
- Quick start 30"
- Drop down grill, 1200 W
- 0-90 min. Timer
- Automatic defrosting by time and weight
- Children safety block
- Double glazed door
- Stainless steel inner cavity
- Tangential ventilation
- Left door opening
- Reinforced grid

COLOR

■ Stainless Steel

FRAME Stainless steel

PRODUCT DIMENSIONS

Height 390mm **Width** 595mm **Depth** 334mm

TOTAL MS 622 BI L



- Microwave
- Ceramic base
- Capacity: 22 litres
- Electromechanical controls
- Electronic door opening
- 5 power levels, 850 W
- 1 cooking function
- 0-60 min. Timer
- Automatic defrosting by time
- Children safety block
- Double glazed door
- Stainless steel inner cavity
- Tangential ventilation
- Reinforced grid

COLOR

■ Stainless Steel

FRAME Stainless steel

PRODUCT DIMENSIONS

Height 390mm **Width** 595mm **Depth** 334mm



Ref. 40584010



Ref. 40584000

TOTAL MS 620 BIS



- Microwave + Grill
- Capacity: 20 litres
- Touch Control panel with TFT white display
- 5 power levels, 750 W
- 3 direct access menus
- 3 cooking functions
- Quick start 30"
- 0-90 min. Timer
- Automatic defrosting by time and weight
- Children safety block
- Double glazed door
- Stainless steel inner cavity
- Quartz Grill, 1000 W
- 1 round grid
- Left door opening

COLOR

■ Stainless Steel

FRAME Stainless steel

PRODUCT DIMENSIONS

Height 390mm **Width** 595mm **Depth** 325mm

EASY MB 620 BI



- Microwave
- Capacity: 20 litres
- Electromechanical controls
- 5 power levels, 750 W
- 1 cooking function
- 0-60 min. Timer
- Automatic defrosting by time
- Double glazed door
- Stainless steel inner cavity
- Left door opening

COLOR

■ Stainless Steel

FRAME Stainless steel

PRODUCT DIMENSIONS

Height 390mm **Width** 595mm **Depth** 325mm

MICROWAVES

TECHNICAL FEATURES

Model	HLC 844 C	MLC 844	MLC 8440	MSC 642
INNER CAVITY DIMENSIONS				
Height (mm)	232	232	232	232
Width (mm)	475	475	475	475
Depth (mm)	365	365	365	405
Volume Net (L)	40	44	44	44
Volume Gross (L)	41	45	45	-
ELECTRICAL FEATURES				
Maximum Nominal Power (W)	3.400	3.200	3.200	3.200
MWO Power (W)	1.000	1.000	1.000	1.000
Static oven (W)	2.100	-	-	-
Bottom Heating Element (W)	1.000	-	-	-
Grill (W)	-	1.400	1.400	1.400
Maxigrill (W)	2.500	-	-	-
Turbo (W)	1.600	-	-	-
Multifunction motor (W)	30	-	-	-
Inner light (W)	25	25	25	25
Cooling fan motor (W)	18	18	18	18
Cable connection length	110	110	110	110
SAFETY SYSTEMS				
Automatic disconnection security system	√	√	√	√
Children safety	√	-	-	-
Grill protection	√	√	√	√
Full glazed door	3	2	√	2

Model	ML 8220 BIS L	ML 822 BIS ML 82 Infinity G1	ML 820 BIS	MS 622 BIS L	MS 622 BI L	MS 620 BIS	MB 620 BI
INNER CAVITY DIMENSIONS							
Height (mm)	220	220	210	220	220	210	210
Width (mm)	350	350	305	350	350	305	305
Depth (mm) (mm)	280	280	280	280	280	280	280
Volume (l)	22	22	20	22	22	20	20
ELECTRICAL FEATURES							
Maximum Nominal Power (W)	2.500	2.500	1.200	2.500	1.400	1.200	1.200
Microwave power	850	850	750	850	850	750	750
Grill power (W)	1.200	1.200	1.000	1.200	-	1.000	-
Cable connection length	110	110	110	110	110	110	110
SAFETY SYSTEMS							
Children safety block	-	√	√	√	-	√	-
Safety thermostat	√	√	√	√	√	√	√
Automatic disconnection when opening the door	√	√	√	√	√	√	√
Tangential ventilation	√	√	-	√	√	-	-

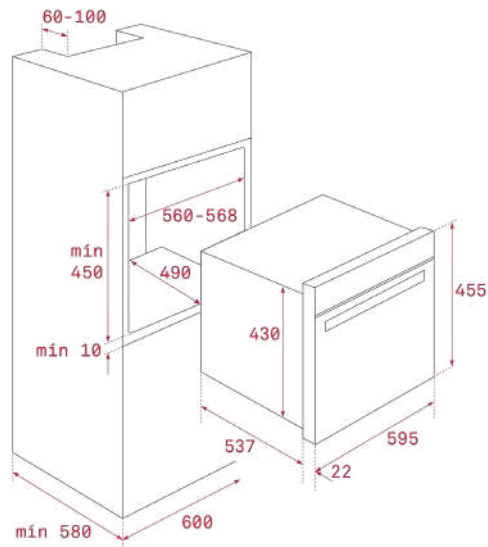

HLC 844 C · MLC 844 · MLC 8440 · MSC 642

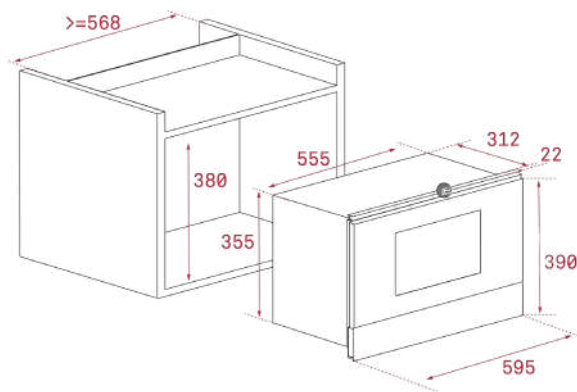

ML 8220 BIS L · ML 82 INFINITY G1 · ML 822 BIS · ML 820 BIS
MS 622 BIS · MS 622BI

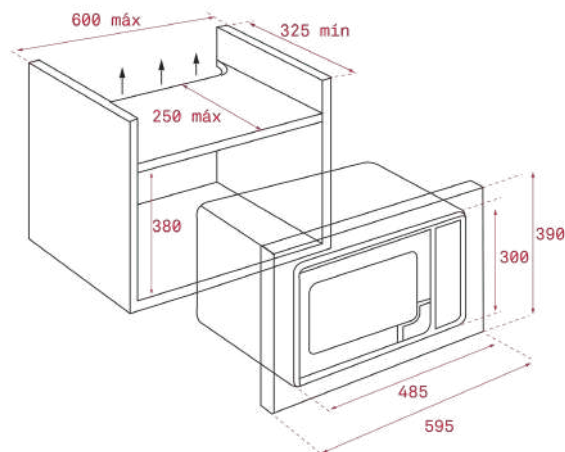

MS 620 BIS · MB 620 BI

Delicious coffee, now faster and **more flavouring** **than ever**

Share unique moments around a cup of exquisite espresso or cappuccino. Our automatic coffee machine adds an exclusive touch of personality and refinement, while amplifying the aromas and flavours of your favourite blends. Choose among built-in capsule coffee machines or with coffee grinder. Because great conversations start with delicious coffee.



Coffee Machine



COFFEE MACHINE



YOUR COFFEE EXPERT, ALWAYS ON HAND

Enjoy the best coffee, whenever you want! The new **WISH** coffee makers will surprise you with the high degree of satisfaction they provide.



COFFEE, STEAM OR JUST HOT WATER?

Featuring an easy and intuitive control panel with easy access to 3 great functions: coffee, steam and hot water.

NOW ALSO FOR COFFEE CAPSULES

You can use different brands of coffee capsules directly in the Teka coffee maker. And if you prefer a cup of tea, that too!



Ref. 40589513

MAESTRO CLC 835 MC



- Multi capsule built-in coffee maker
- Multi capsule (*) and ground coffee machine
- Coffee selector: small, medium, large, extra large and infusions
- Electronic control panel with TFT display
- 5 adapters included
- Automatic LED lights
- Capacity: 1 cup
- Adjustable height cup support
- Temperature selector
- Storage drawer
- 2 side storage compartments
- Drip tray
- 19 bar pump pressure
- 1 litre water tank
- Waste container
- Automatic decalcifier
- Descalling function
- *5 capsule adaptors: Nespresso®, Lavazza®, Caffitaly®, E.S.E pod, Coffee powder

COLOR

Black Glass

FRAME Stainless steel

PRODUCT DIMENSIONS

Height 455mm **Width** 595mm **Depth** 330mm



Ref. 111630004



Ref. 111630003

MAESTRO CLC 855 GM BK



- Urban color Edition
- Automatic built-in coffee machine
- Self-cleaning function
- Intensity, temperature and coffee quantity regulation
- Electronic control display
- Telescopic rails for an easy pull out of the coffee maker
- 30 automatic programs
- Automatic LED lights
- Capacity: 2 cups at once
- Easy removable container for coffee grounds
- 15 bar pump pressure
- Adjustable coffee, steam, and hot water pipes
- Integrated steel grinder for natural coffee beans (13 different ground positions)
- Coffee beans container, 200 gr capacity
- Pre-grounded coffee container
- 1,8 litres water tank
- Automatic decalcifier

COLOR

 **Black Glass**

FRAME Infinity glass

PRODUCT DIMENSIONS

Height 455mm **Width** 595mm **Depth** 411mm

MAESTRO CLC 855 GM ST



- Urban color Edition
- Automatic built-in coffee machine
- Self-cleaning function
- Intensity, temperature and coffee quantity regulation
- Electronic control display
- Telescopic rails for an easy pull out of the coffee maker
- 30 automatic programs
- Automatic LED lights
- Capacity: 2 cups at once
- Easy removable container for coffee grounds
- 15 bar pump pressure
- Adjustable coffee, steam, and hot water pipes
- Integrated steel grinder for natural coffee beans (13 different ground positions)
- Coffee beans container, 200 gr capacity
- Pre-grounded coffee container
- 1,8 litres water tank
- Automatic decalcifier

COLOR

 **Stone Grey Glass**

FRAME Infinity glass

PRODUCT DIMENSIONS

Height 455mm **Width** 595mm **Depth** 411mm

COFFEE MACHINE

TECHNICAL FEATURES

Model	CLC 835 MC	CLC 855 GM
Multicapsule	√	-
INNER CABINET DIMENSIONS		
Cabinet height (mm)	450	450
Cabinet width (mm)	560	560
Cabinet depth (mm)	580	-
ELECTRICAL FEATURES		
Maximum Nominal Power (W)	2.100	1.350
Cable connection length	110	180

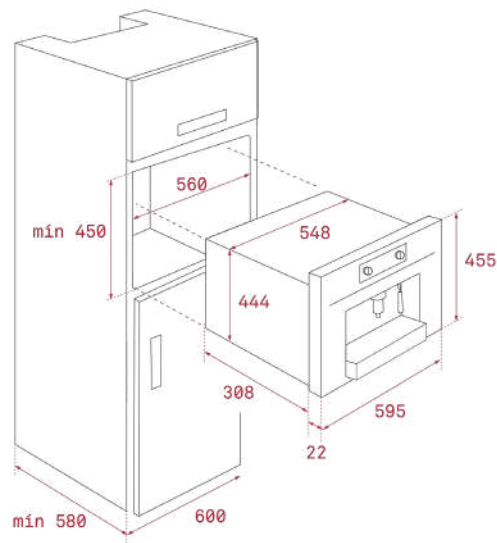

CLC 835 MC

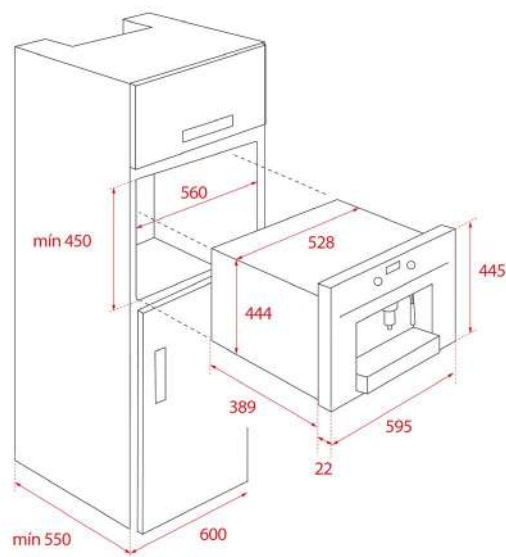

CLC 855 GM



Hobs

Add some of your own magic
to each of your recipes

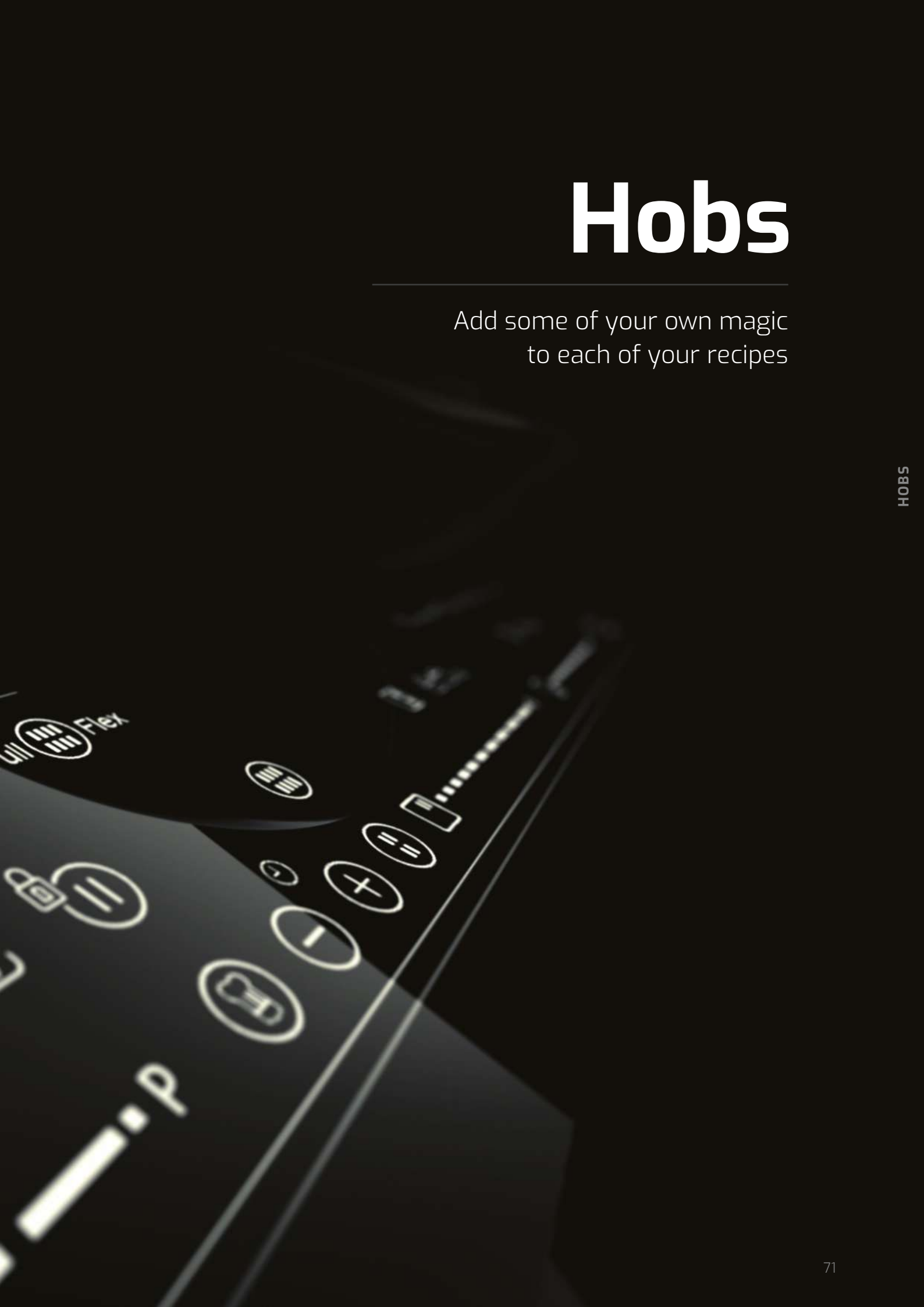

WORLDWIDE **NOVELTY**

Infinity | G1 Edition

COOKING WILL NEVER BE THE SAME

The new Infinity | G1 Edition Induction and Gas Hobs will be the solution to enjoy cooking like never before.

Their black matt finishing with copper details make them a work of art, with fine lines and tasteful details.

Our Infinity | G1 Edition Induction Hobs, with Flex cooking zones, ceramic glass surface and direct functions, will prove to be the ideal cooking assistant, accompanying you at every step of the cooking process.

In the case of our Infinity | G1 Edition Gas Hobs, their ergonomic knobs will be a pleasure to touch and use. Their glass top, easy to clean, gives an elegant touch to any kitchen.



Designed down to the last detail

Outstanding combination of black glass and copper details. Ergonomic and great-looking control panel, for the most absolute convenience.



Options to choose from

Induction or gas: choose your favorite and enjoy either way.



Discover the complete edition

Get the most out of your Infinity | G1 Edition Hobs, by matching them with the rest of the products of the edition.



SCAN AND
DISCOVER

VarioPro Series

REINVENT YOUR KITCHEN

Discover our new VarioPro series. A modular range that you can design to suit your kitchen and your lifestyle, with the hood where you need it most, next to your hob.

Choose and combine your hood as you wish with Induction, Gas, Highlight hobs or Teppanyaki.



SCAN AND
DISCOVER

Simmering Melting



TEKA

SCHOTT CERAN®

T

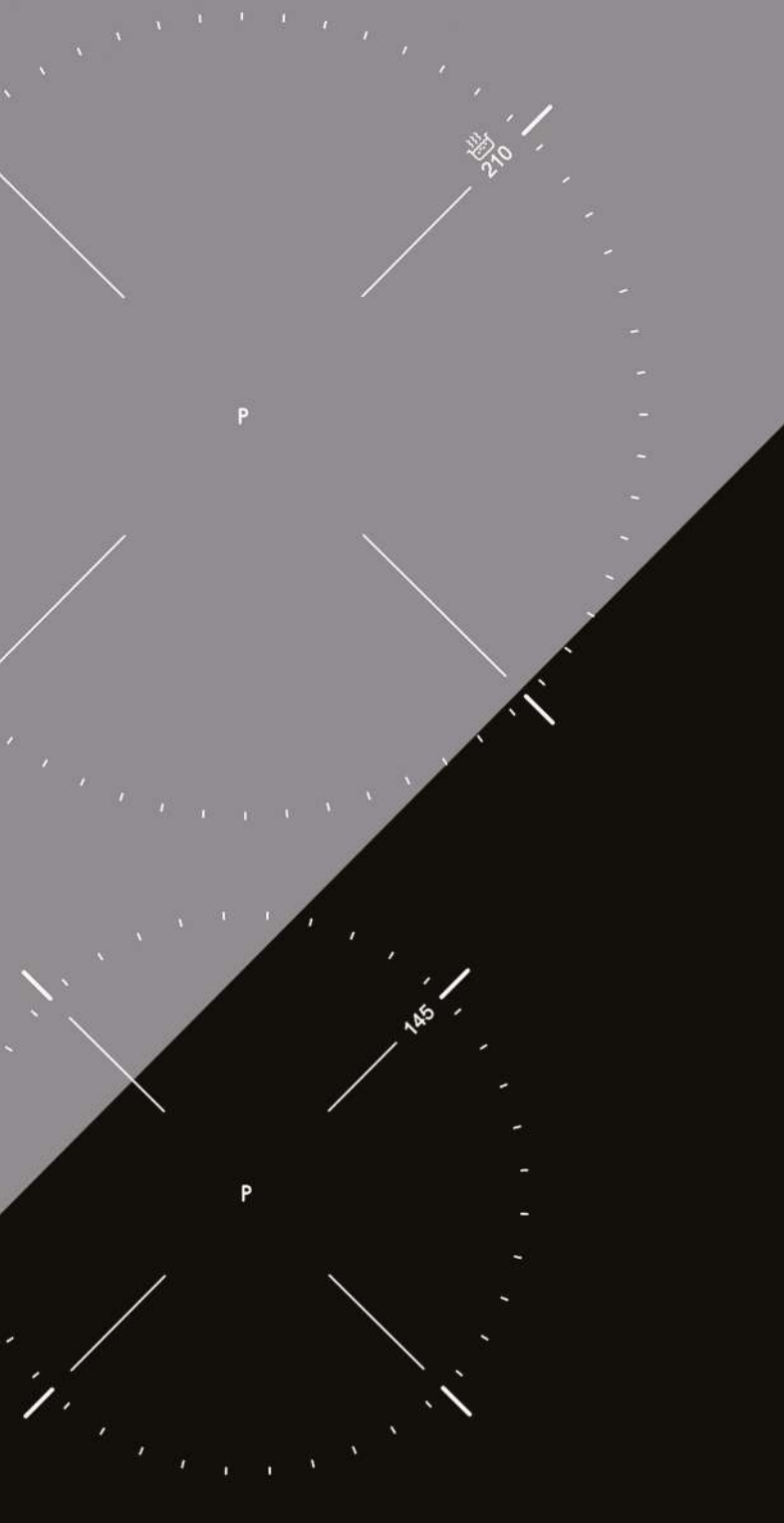

Keep warm Slide Cooking



induction

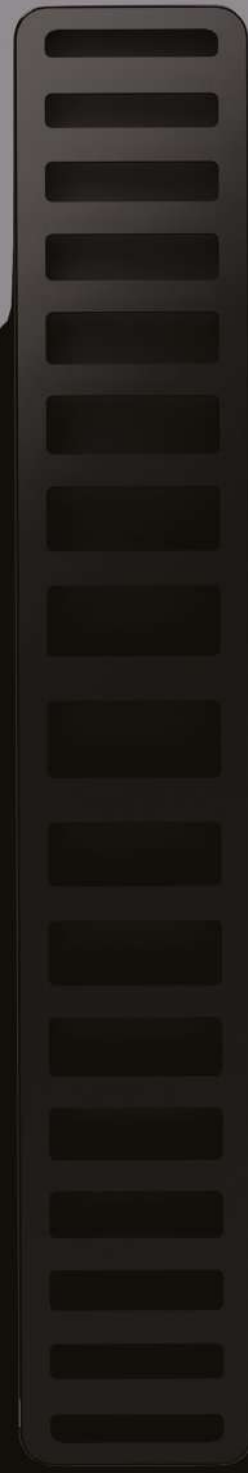

TEKA

HOBBS

Cooking **without limits**



Full Flex DirectSense induction

Cook with no limits thanks to its FullFlex technology using the whole cooking surface. Use your imagination and cook with recipients of any size, your recipes won't have limits.

DirectSense control the Temperature using sensors avoids oil to reach excessively high temperatures. Use your imagination and cook with recipients of any size at the perfect temperature without limits.

Space induction

Flex area is designed to use every single corner of the cooking area with different shape pans. Perfect for grids, grill, TeppanYaki or rectangular recipients.



Old traditional cooking with the **newest technology**

ExactFlame

Trying to guess the power of the flame is just part of the past.









With ExactFlame you can easily control flame intensity with the highest precision. You can choose a range of power from 1 to 9, ready for any kind of cooking you need at any time.

- Power 8 to 9:**
 - Deep Frying
 - Quick Boiling
 - Stir Frying
- Power 4 to 5:**
 - Pasta
 - Boiled Potatoes
 - Vegetables
- Power 1:**
 - Keep Warm
- Power 6 to 7:**
 - Pan Frying
 - Simmering
- Power 2 to 3:**
 - Melting
 - Bain-Marie

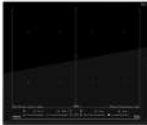

Hobs

Teka adds soul to your kitchen.

		MAESTRO				
		MULTISLIDER	TOUCH CONTROL	MULTISLIDER		
INDUCTION	90	 IZS 97630	 IZS 96600			
	60	 DIRECTSENSE IZF 68600		 IBF 64 - G1 MSP BM	 IZC 64630 WH MST	 IZC 64630 ST MST
	MODULAR	 IZS 34700				
VITROCERAMIC	90		 TR 951			
	60		 TBC 63632 TTC BK			
	MODULAR					

MAESTRO

Domestic appliances for those who like going one step further. For those who will not settle for being like the rest.

TOTAL

Designed for those who demand everything of their appliances, for everyone in the house. Maximum effectiveness in any situation.

EASY

For those who prefer no complications in the kitchen without denying themselves an appliance that gives so much while asking for so little in return.

TOTAL		EASY		
TOUCH CONTROL	STAINLESS STEEL	MULTISLIDER	TOUCH CONTROL	MECHANICAL



IZC 64010 BK MSS



TZ 6420











TBC 64000 XFL



TZC 32320 BK TTC



EFX 30.1 2H

		MAESTRO		
		GAS ON GLASS	STAINLESS STEEL	
GAS + INDUCTION	90	 <p>JZC 96342 BBB</p>		
	60	 <p>JZC 64322 ABB</p>		
GAS	90	 <p>GZC 95320</p>	 <p>EW 90 5G AI AL TR CI</p>	
	70	 <p>GBC 75- G1 GBC BM</p>		
	60	 <p>GZC 64320 WH</p>	 <p>GZC 64300 BK</p>	 <p>GZC 64320 ST</p>
	MODULAR			
ELECTRIC	MODULAR	 <p>YZC 32600</p>		

TOTAL		EASY
GAS ON GLASS	STAINLESS STEEL	STAINLESS STEEL



EX 90.1 5G AI AL DR CI



EX 90.1 5G AI AL DR LEFT CI BUT



EFX 90.1 5G AI AL DR LEFT



EFX 60.1 4G AI AL
DR CI BTN (ME)



EFX 60.1 4G AI AL
DR CI BTN (E1)



HLX 640 KB



GZC 32309



EFX 30.1 2G AI AL CI



EFX 30.1 FRYER



EFX 30.1 GRILL

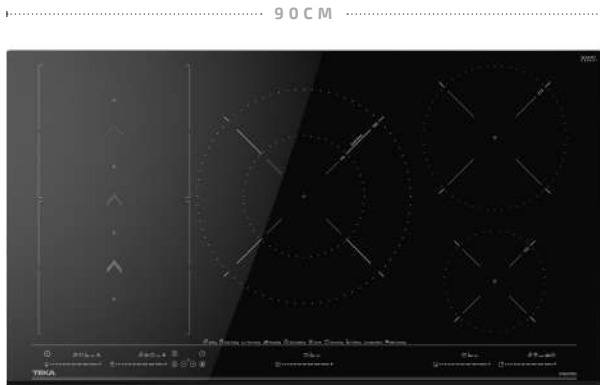

Ref. 112500034

NEW

MAESTRO IZS 97630 MST BK



- 90 cm Flex Induction hob
- SlideCooking function
- 9 Direct functions with temperature sensors: Confit, poaching, grilling, pan frying, deep frying, quick boiling, simmering, melting and keep warm
- Touch Control MultiSlider
- 5 cooking zones
 - 1 zone Ø 320/180 mm
 - 2 zones Ø 228 x 200 mm
 - 1 zone Ø 215 mm
 - 1 zone Ø 150 mm
- Ceramic glass surface
- Auto-lock safety system
- Cooking timer
- Power plus
- Child lock
- Residual heat indicator
- Power management
- Easy installation kit
- Maximum nominal power 10.800 W

COLOR

Black Glass

FRAME Front bevelled glass

PRODUCT DIMENSIONS

Height 53mm **Width** 900mm **Depth** 510mm

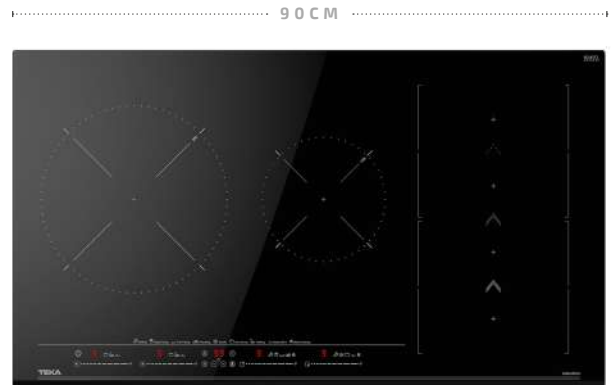

Ref. 112500033

NEW

MAESTRO IZS 96700 MST



- 90 cm Flex Induction hob
- SlideCooking function
- Direct functions with temperature sensors: Confit, poaching, grilling, pan frying, deep frying, quick boiling, simmering, melting and keep warm
- Touch Control MultiSlider
- 4 cooking zones
 - 1 zone Ø 280 mm
 - 2 zone Ø 228 x 200 mm
 - 1 zone Ø 185 mm
- Ceramic glass surface
- Auto-lock safety system
- Cooking timer
- Power plus
- Child lock
- Residual heat indicator
- Power management
- Easy installation kit
- Maximum nominal power 7200 W

COLOR

Black Glass

FRAME Front bevelled glass

PRODUCT DIMENSIONS

Height 53mm **Width** 900mm **Depth** 510mm

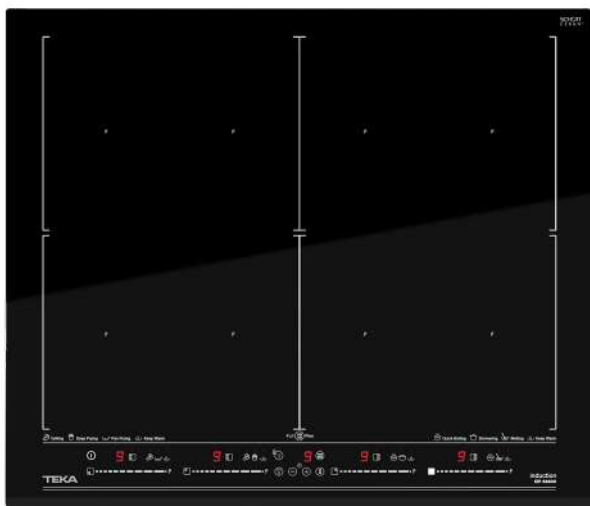

Ref. 112500037

NEW**MAESTRO DIRECTSENSE IZF 68700**

- FullFlex 60 cm Induction hob
- Direct functions with temperature sensors: Rice cooking, confit, poaching, grilling, pan frying, deep frying, quick boiling, keep warm, simmering and melting.
- MasterSense Series
- Touch Control MultiSlider
- 4 cooking zones
4 zones Ø 262,5 X 195 mm
- Ceramic glass surface
- Auto-lock safety system
- Cooking timer
- Power plus
- Child lock
- Residual heat indicator
- Power management
- Easy installation kit
- Maximum nominal power 7400 W

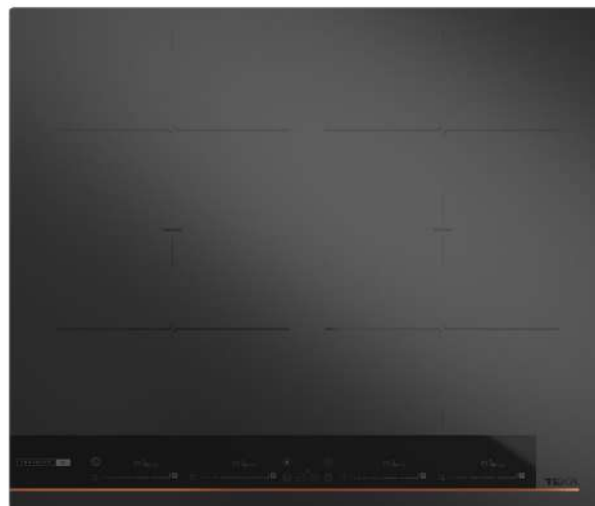
COLOR
 **Black Glass**
FRAME Front bevelled glass**PRODUCT DIMENSIONS****Height** 57mm **Width** 600mm **Depth** 510mm

Ref. 112510038

NEW**MAESTRO IBF 64 INFINITY G1**

- Infinity G1 special edition
- Designed in Italy by Giugiaro Italdesign
- Flex induction hob
- Exclusive matte black finishing
- Direct functions: Simmering, melting and keep warm
- Touch Control MultiSlider
- 4 cooking zones
- 4 Flex zones Ø 235 X 188,5 mm
- Ceramic glass surface
- Auto-lock safety disconnection
- Cooking timer
- Power Plus
- Child lock
- Residual heat indicator
- Power management
- Easy installation kit
- Maximum nominal power 7200 W

COLOR
 **Black Matt**
PRODUCT DIMENSIONS**Height** 53mm **Width** 600mm **Depth** 510mm



Ref. 112500027

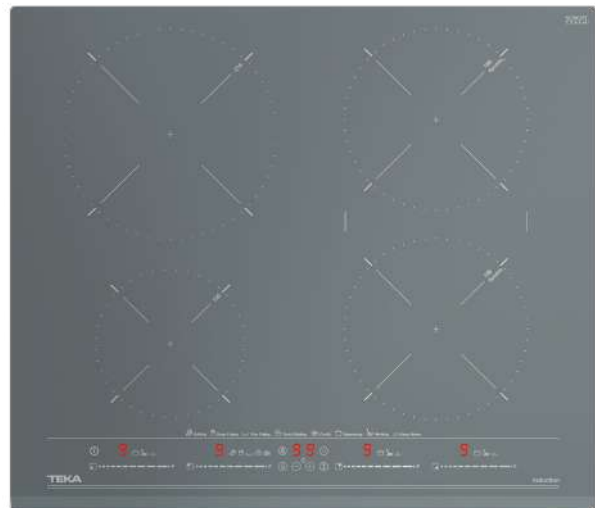

Ref. 112500026

MAESTRO IZC 64630 WH MST



- Urban Colors Edition
- Induction hob
- Touch control MultiSlider
- Cooking timer
- 4 cooking zones:
 - 1 induction Ø 215 mm
 - 2 induction Ø 185 mm
 - 1 induction Ø 150 mm
- Special cooking functions with temperature sensors: Grilling, Deep frying, Pan frying, KeepWarm, Boiling, Simmering, Confit & Melting
- Power Plus function
- Stop & Go function
- Residual heat indicators
- Fast-Click easy installation
- Maximum nominal power : 8.800 W

MAESTRO IZC 64630 ST MST



- Urban Colors Edition
- Induction hob
- Touch control MultiSlider
- Cooking timer
- 4 cooking zones:
 - 1 induction Ø 215 mm
 - 2 induction Ø 185 mm
 - 1 induction Ø 150 mm
- Special cooking functions with temperature sensors: Grilling, Deep frying, Pan frying, KeepWarm, Boiling, Simmering, Confit & Melting
- Power Plus function
- Stop & Go function
- Residual heat indicators
- Fast-Click easy installation
- Maximum nominal power : 8.800 W

COLOR

White Glass

FRAME Front bevelled glass

PRODUCT DIMENSIONS

Height 50mm **Width** 600mm **Depth** 510mm

COLOR

Stone Grey Glass

FRAME Front bevelled glass

PRODUCT DIMENSIONS

Height 50mm **Width** 600mm **Depth** 510mm

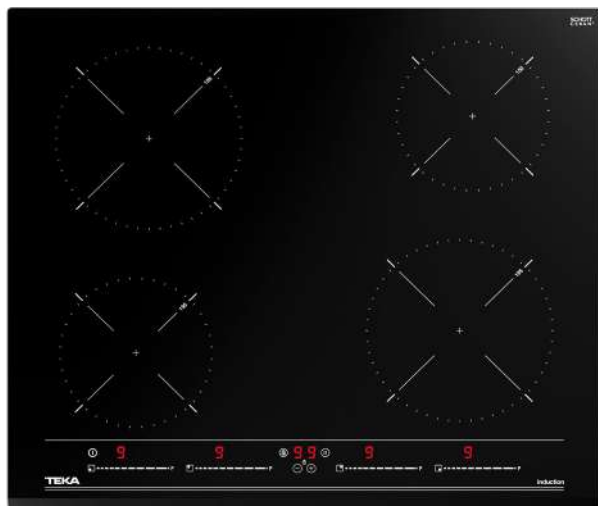

Ref. 112520015

EASY IZC 64010 BK MSS



- 60 cm Induction hob
- Touch control MultiSlider
- Cooking timer
- 4 cooking zones:
2 induction Ø 185 mm
2 induction Ø 150 mm
- Power Plus function
- Stop & Go function
- Residual heat indicators
- Fast-Click easy installation
- Maximum nominal power : 7.200 W

COLOR

■ Black Glass

FRAME Front bevelled glass

PRODUCT DIMENSIONS

Height 50mm **Width** 600mm **Depth** 510mm

90 CM

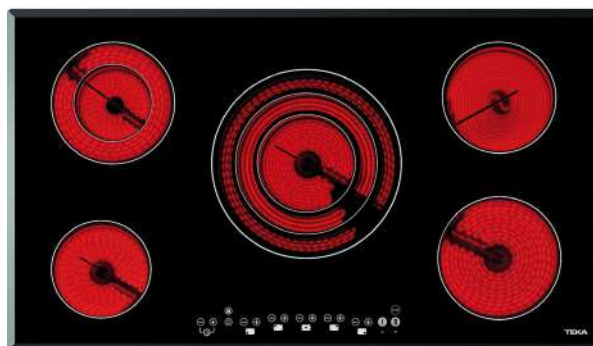

Ref. 10210002

MAESTRO TR 951



- 90 cm vitroceramic hob
- Touch control panel
- Burst of cooking function
- Stop and Go function
- Security blocking
- Cooking time programmer
- Independent programmer of each cooking zone
- Residual heat indicator
- 5 cooking zones :
1 triple high light Ø 145/210/270 mm
1 double high light Ø 120/180 mm
1 high light Ø 180 mm
1 high light Ø 160 mm
1 high light Ø 145 mm
- Total nominal power : 8.900 W

COLOR

■ Black Glass

FRAME Full bevelled glass

PRODUCT DIMENSIONS

Height 63mm **Width** 900mm **Depth** 510mm

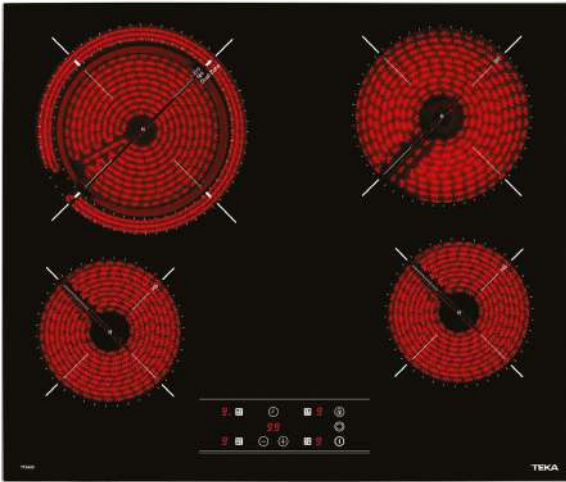

Ref. 40239021

NEW

TOTAL TT 6420



- Vitroceramic hob
- Touch Control
- 4 cooking zones
 - 1 high lights Ø 180/210 mm
 - 1 high lights Ø 180 mm
 - 2 high lights Ø 145 mm
- Ceramic glass surface
- Auto-lock safety system
- Cooking timer
- Power plus
- Child lock
- Residual heat indicator
- Easy installation kit
- Maximum nominal power 6200 W

COLOR

Black Glass

FRAME Slim metal frame

PRODUCT DIMENSIONS

Height 51mm **Width** 600mm **Depth** 515mm

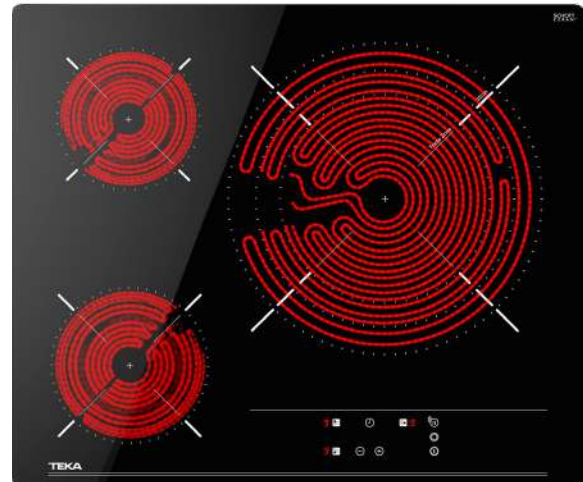

Ref. 112530007

NEW

MAESTRO TBC 63632 TTC



- Vitroceramic hob
- Frontal Touch Control
- 3 cooking zones
 - 1 high lights Ø 320/260/210 mm
 - 1 high lights Ø 160 mm
 - 1 high lights Ø 145 mm
- Ceramic glass surface
- Auto-lock safety disconnection
- Cooking timer
- Power plus
- Child lock
- Residual heat indicator
- Easy installation kit
- Maximum nominal power 6700 W

COLOR

Black Glass

FRAME C-edged glass

PRODUCT DIMENSIONS

Height 64mm **Width** 600mm **Depth** 510mm

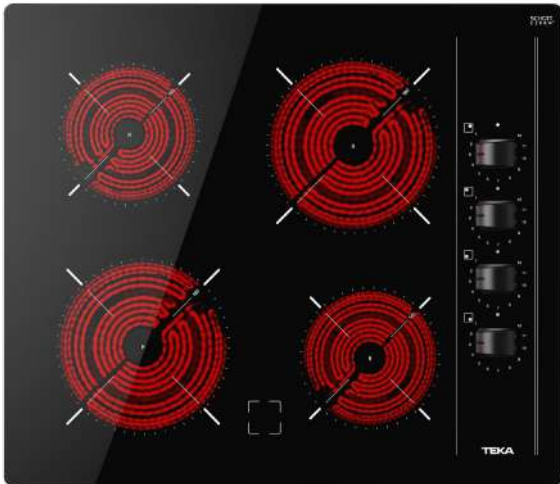

Ref. 112550009

EASY TBC 64000 XFL



- 60cm vitroceramic hob
- Black Ergonomic Knob
- 4 cooking zones:
 - 2 high light Ø 180 mm
 - 2 high light Ø 145 mm
- Fast-Click easy installation
- Maximum nominal power: 6.000 W

COLOR

 Black Glass

FRAME C-edged glass

PRODUCT DIMENSIONS

Height 57mm **Width** 600mm **Depth** 510mm



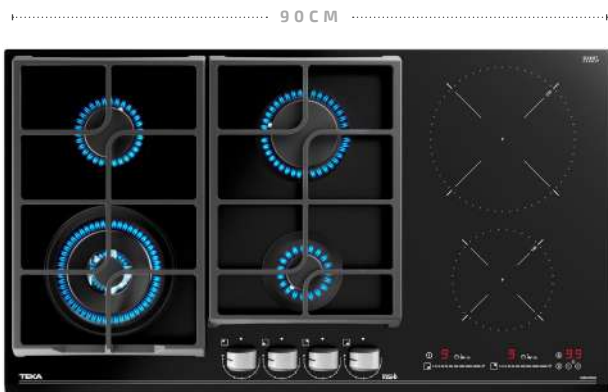

Ref. 112570144

MAESTRO JZC 96342 BBB



- Gas on glass + Induction hob
- Touch control MultiSlider
- ExactFlame control
- Cooking timer
- 6 cooking zones:
 - 1 double ring burner 4.00 kW
 - 1 induction 145 Ø (1250-1800 W)
 - 1 induction 180 Ø (1700 - 2100 W)
 - 1 gas rapid burner (2.8 kW)
 - 1 gas semi-rapid burner (1.75 kW)
 - 1 gas auxiliary burner (1.0 kW)
- 9 gas power levels with precise control of the flame
- Large cast iron grids
- Automatic-ignition
- Auto-lock safety device
- Induction Power Plus function
- 3 special cooking functions: Simmering, Melting and KeepWarm
- Maximum nominal power (gas): 6.95 kW
- Maximum nominal power (induction): 3500 W
- Ceramic Glass (4 mm)
- Gas typology: LPG (butan/propane)
- Nozzles to natural gas

COLOR

 **Black Glass**

FRAME Front bevelled glass

PRODUCT DIMENSIONS

Height 55mm **Width** 900mm **Depth** 510mm



Ref. 112570069

MAESTRO GZC 95320



- Gas on Glass with ExactFlame
- Front control knobs with ergonomic design
- Ceramic glass surface
- 9 power levels with precise control of the flame
 - 1 double ring burner, 4,00 kW
 - 1 fast burner, 2,80kW
 - 1 semi-fast burner, 1,75 kW
 - 1 semi-fast burner, 1,4 kW
 - 1 auxiliary burner, 1,00 kW
- Auto-lock safety device (Thermocouples)
- Automatic-ignition in every burner, activated through control knobs
- Optional Wok support
- Large cast iron pan grids
- Easy installation kit
- Gas typology: LPG (butan/propane)
- Nozzles to natural gas

COLOR

 **Black Glass**

FRAME Front bevelled glass

PRODUCT DIMENSIONS

Height 50mm **Width** 900mm **Depth** 510mm

70 CM



Ref. 112570210

NEW

MAESTRO GBC 75 INFINITY G1



- Infinity | G1 Edition
- Designed in Italy by Giugiaro Italdesign
- Gas on Glass hob
- Exclusive matte black finishing
- Frontal mechanical control panel with ergonomic design
- 5 cooking zones
- 1 double ring burner, 3,50 kW
- 1 fast burner, 2,80 kW
- 1 semi fast burner, 1,75 kW
- 1 semi fast burner, 1,40 kW
- 1 auxiliary burner, 1,00 kW
- Ceramic glass surface
- Auto ignition
- Auto-lock safety system
- Cast iron grids
- Easy installation kit
- Maximum nominal power 10450 W
- Optional: Wok support

COLOR

Black Matt

PRODUCT DIMENSIONS

Height 50mm **Width** 700 mm **Depth** 510mm



Ref. 112570145

MAESTRO JZC 64322 ABB



- Gas on glass + Induction hob
- Touch control MultiSlider
- ExactFlame control
- Cooking timer
- 4 cooking zones:
 - 1 induction 210 Ø (2250-3000 W)
 - 1 induction 145 Ø (1250-1800 W)
 - 1 gas rapid burner (2.8 kW)
 - 1 gas auxiliary burner (1.0 kW)
- 9 gas power levels with precise control of the flame
- Large cast iron grids
- Automatic-ignition
- Auto-lock safety device
- Induction Power Plus function
- 3 special cooking functions: Simmering, Melting and KeepWarm
- Maximum nominal power (gas): 4.0 kW
- Maximum nominal power (induction): 3500 W
- Ceramic Glass (4 mm)
- Gas typology: LPG (butan/propane)
- Nozzles to natural gas

COLOR

Black Glass

FRAME Front bevelled glass

PRODUCT DIMENSIONS

Height 55mm **Width** 600mm **Depth** 510mm



Ref. 112570033

MAESTRO GZC 64300 BK



- Gas on Glass with ExactFlame
- 9 power levels with precise control of the flame
- Front control knobs with ergonomic design
- 4 cooking zones:
 - 1 semi-fast burner (1.4 kW)
 - 1 semi-fast burners (1.75 kW)
 - 1 fast burner (2.80 kW)
 - 1 auxiliary burner (1.00 kW)
- Large cast iron grids
- Automatic-ignition in every burner, activated through control knobs
- Auto-lock safety device (Thermocouples)
- Optional Wok support
- Easy installation kit
- Ceramic glass surface
- Gas typology: LPG (butan/propane)
- Nozzles to natural gas

COLOR

Black Glass

FRAME Front bevelled glass

PRODUCT DIMENSIONS

Height 50mm **Width** 600mm **Depth** 510mm



Ref. 112570140

MAESTRO GZC 64320 WH



- Urban Colors Edition
- Gas on Glass with ExactFlame
- 9 power levels with precise control of the flame
- Front control knobs with ergonomic design
- 4 cooking zones:
 - 1 double ring burner (4.00 kW)
 - 1 semi-fast burner (1.75 kW)
 - 1 fast burner (2.80 kW)
 - 1 auxiliary burner (1.00 kW)
- Large cast iron grids
- Automatic-ignition in every burner, activated through control knobs
- Auto-lock safety device (Thermocouples)
- Optional Wok support
- Easy installation kit
- Ceramic glass surface
- Gas typology: LPG (butan/propane)
- Nozzles to natural gas

COLOR

Glass White

FRAME Front bevelled glass

PRODUCT DIMENSIONS

Height 50mm **Width** 600mm **Depth** 510mm



Ref. 112570141

MAESTRO GZC 64320 ST



- Urban Colors Edition
- Gas on Glass with ExactFlame
- 9 power levels with precise control of the flame
- Front control knobs with ergonomic design
- 4 cooking zones:
 - 1 double ring burner (4.00 kW)
 - 1 semi-fast burner (1.75 kW)
 - 1 fast burner (2.80 kW)
 - 1 auxiliary burner (1.00 kW)
- Large cast iron grids
- Automatic-ignition in every burner, activated through control knobs
- Auto-lock safety device (Thermocouples)
- Optional Wok support
- Easy installation kit
- Ceramic glass surface
- Gas typology: LPG (butan/propane)
- Nozzles to natural gas

COLOR

 Stone Grey Glass

FRAME Front bevelled glass

PRODUCT DIMENSIONS

Height 50mm **Width** 600mm **Depth** 510mm





Ref. 40219018

MAESTRO EW 90 5G AI AL TR CI



- 90 cm gas hob
- Triple ring burner
- Cast iron grids
- Metal looking frontal knobs
- Flash-fit surface
- Auto-ignition
- Auto-lock safety device
- 5 cooking zones :
 - 1 triple ring burner (3.1 kw)
 - 1 fast burner (2.8 kW)
 - 1 semi-fast burner (1.75 kW)
 - 1 semi-fast burner (1.4 kW)
 - 1 auxiliary burner (1 kW)
- Gas typology: LPG (butane/propane)
- Nozzles to natural gas

COLOR

 Stainless Steel

FRAME Frameless

PRODUCT DIMENSIONS

Height 70mm **Width** 870mm **Depth** 520mm

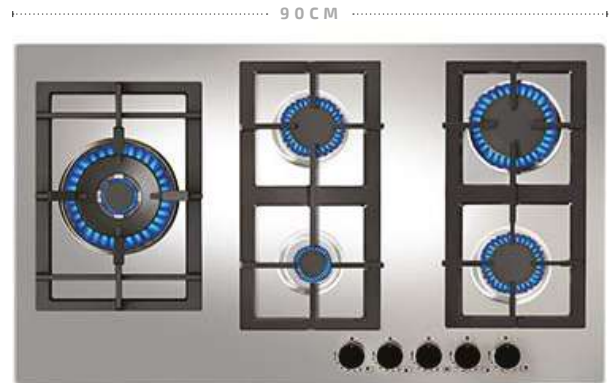

Ref. 40211631

TOTAL EFX 90.1 5G AI AL DR LEFT



- 90 cm gas hob
- Double ring burner
- Cast iron grids
- Metallic and glossy black looking frontal knobs
- Auto-ignition
- Auto-lock safety device
- High efficiency burners
- 5 cooking zones :
 - 1 double ring burner (4 kw)
 - 1 fast burner (3 kW)
 - 2 semi-fast burners (1.75 kW)
 - 1 auxiliary burner (1 kW)
- Gas typology : LPG (butane/propane)
- Nozzles to natural gas

COLOR

 Stainless Steel

FRAME Brushed stainless steel

PRODUCT DIMENSIONS

Height 45mm **Width** 860mm **Depth** 510mm

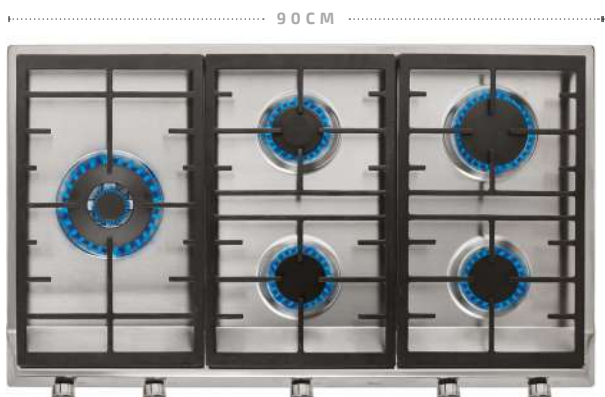

Ref. 40212503

NEW

TOTAL EX 90.1 5G AI AL DR LEFT CI BUT



- 90 cm gas hob
- Double ring burner
- Cast iron grids with a professional look.
- Metallic and glossy black looking frontal knobs
- Auto-ignition
- Auto-lock safety device
- High Efficiency burners.
- 5 cooking zones:
 - 1 rapid (2.80 kW)
 - 1 auxiliary (1 kW)
 - 1 semirapid (1.75 kW)
 - 1 semirapid (1.75 kW)
 - 1 double ring (4 kW)
- Gas typology: LPG (butane/ propane)
- Nozzles to natural gas

COLOR

 **Stainless Steel**

FRAME Brushed stainless steel

PRODUCT DIMENSIONS

Height 33mm **Width** 860mm **Depth** 500mm

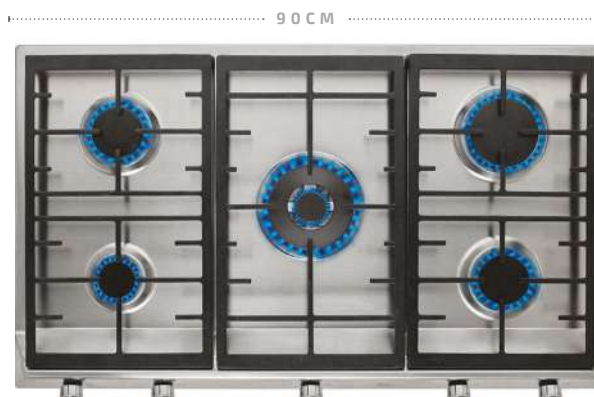

Ref. 40212063

TOTAL EX 90.1 5G AI AL DR CI BUT



- 90 cm gas hob
- Double ring burner
- Cast iron grids with a professional look.
- Metallic and glossy black looking frontal knobs
- Auto-ignition
- Auto-lock safety device
- High Efficiency burners.
- 5 cooking zones:
 - 1 double ring burner (4.00 kW)
 - 1 fast burner (2.8 kW)
 - 2 semi-fast burner (1.75 kW)
 - 1 auxiliary burner (1kW)
- Gas typology: LPG (butane/ propane)
- Nozzles to natural gas

COLOR

 **Stainless Steel**

FRAME Brushed stainless steel

PRODUCT DIMENSIONS

Height 33mm **Width** 860mm **Depth** 500mm



Ref. 112610072

TOTAL EFX 60.1 4G AI AL DR CI BTN (ME)



- 60 cm gas hob
- Double ring burner
- Cast iron grids
- Metallic and glossy black looking frontal knobs
- Auto ignition
- Auto-lock safety system
- 4 cooking zones
 - 1 double ring burner (4.00 kW)
 - 2 semi-fast burners (1.75 kW)
 - 1 auxiliary burner (1 kW)
- Gas typology: LPG (butane/propane)
- Nozzles to natural gas

COLOR

 **Stainless Steel**

FRAME Brushed stainless steel

PRODUCT DIMENSIONS

Height 45mm **Width** 600mm **Depth** 510mm



Ref. 112610042

NEW

TOTAL EX 60.1 4G AI AL DR CI BTN (E1)



- 60 cm gas hob
- Double ring burner
- Cast iron grids
- Frontal control knobs
- Auto ignition
- Auto-lock safety system
- 4 cooking zones
 - 1 double ring burner (4.00 kW)
 - 1 fast burner (2.8 kW)
 - 1 semi fast burner (1.7 kW)
 - 1 fast burner (1 kW)
- Gas typology: LPG (butane/propane)
- Nozzles to natural gas

COLOR

 **Stainless Steel**

FRAME Brushed stainless steel

PRODUCT DIMENSIONS

Height 84mm **Width** 580mm **Depth** 500mm



Ref. 112620020

NEW**EASY HLX 640 KB**

- 60 cm gas hob
- Enamelled grids
- Lateral mechanical control panel with ergonomic design
- Auto ignition
- Auto-lock safety system
- 4 cooking zones
 - 1 fast burner (3 kW)
 - 2 semi fast burners (1.75 kW)
 - 1 auxiliary burner (1 kW)
- Stainless steel surface

COLOR

 **Stainless Steel**

FRAME Brushed stainless steel

PRODUCT DIMENSIONS

Height 85mm **Width** 580mm **Depth** 500mm



Ref. 40214555

TOTAL EFX 30.1 2G AI AL CI BUT

- Modular gas hob
- Stainless steel Surface
- Cast iron grid
- Auto-ignition
- Auto-lock safety device
- High Efficiency burners
- Metallic and glossy black looking frontal knob
- 2 cooking zones:
 - 1 fast burner (3.00 kW)
 - 1 auxiliary burner (1.00 kW)
- Gas typology: LPG (butane/propane)
- Nozzles to natural gas

COLOR

 **Stainless Steel**

PRODUCT DIMENSIONS

Height 45mm **Width** 305mm **Depth** 510mm

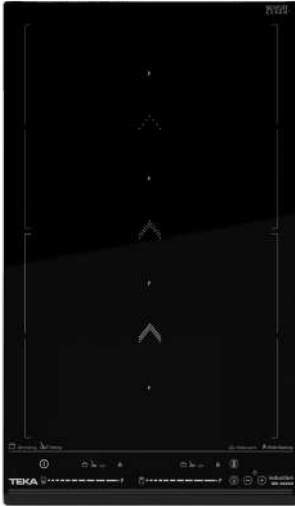

Ref. 112530001

NEW

MAESTRO IZS 34700 MST BK



- VarioPro Series
- Modular Flex Induction hob
- SlideCooking function
- Direct functions with temperature sensors: Poaching, confit, grilling, pan frying, deep frying, simmering and keep warm
- Touch Control MultiSlider
- 2 cooking zones
 - 1 Slide Flex zone 255 x 400 mm
 - 2 zones 255 x 200 mm
- Auto-lock safety system
- Cooking timer
- Power plus
- Child lock
- Residual heat indicator
- Power management
- Easy installation kit
- Maximum nominal power 3600 W

COLOR

 **Black Glass**

FRAME Front bevelled glass

PRODUCT DIMENSIONS

Height 53mm **Width** 300mm **Depth** 510mm



Ref. 112660000

NEW

MAESTRO YZC 32600 TEPPANYAKI



- VarioPro Series
- Modular teppanyaki hob
- Frontal control knobs with ergonomic design
- 2 cooking zones
 - 2 zones Ø 376 X 118 mm
- Ceramic glass surface
- Easy cleaning
- Max.nominal power: 2400 W

COLOR

 **Black Glass**

FRAME Front bevelled glass

PRODUCT DIMENSIONS

Height 79mm **Width** 300mm **Depth** 510mm



Ref. 113160000

NEW**MAESTRO FIH 16760 TOS BK**

- VarioPro Series
- Modular Flow-in hood
- Touch control
- FreshAir function
- Energy Efficiency Class: A+
- Brushless EcoPower Motor
- 3 speeds + 1 intensive
- Free Outlet exhaust capacity (m3/h): 630
- Intensive speed exhaust capacity (m3/h): 600
- Max speed exhaust capacity (m3/h): 540
- Min speed exhaust capacity (m3/h): 415
- Intensive speed sound level (dBA): 70
- Max speed sound level (dBA): 67
- Min speed sound level (dBA): 62
- 1 mesh washable filter
- Stop delay timer
- Filter saturation indicator
- Operating pilot light
- Optional regenerative charcoal filters

Filter required for installation without outlet:
Recirculation Kit including Regenerative
Charcoal Filter - RFH 36100 FOA

Ref.113290013

Regenerative Charcoal Filter - R1RFB

Ref.113290014

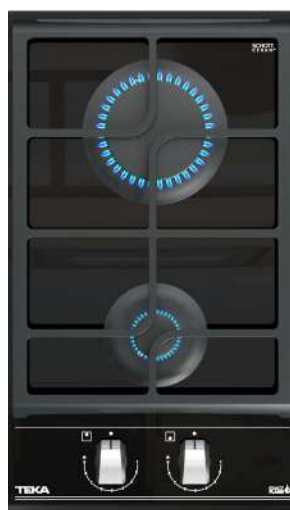
COLOR
 **Black Glass**
PRODUCT DIMENSIONS**Width** 110mm **Depth** 510mm

Ref. 112570180

NEW**TOTAL GZC 32309 XBB ME**

- VarioPro Series
- Modular gas on glass hob
- ExactFlame
- Frontal control knobs with ergonomic design
- 2 cooking zones
 - 1 semi fast burner, 1.7 kW
 - 1 auxiliary burner, 1 kW
- Ceramic glass surface
- Auto ignition
- Auto-lock safety system
- Cast iron grids
- Easy installation kit
- Maximum nominal power 2750 W
- Includes deflector accessory for VarioPro hood

COLOR
 **Black Glass**
FRAME Front bevelled glass**PRODUCT DIMENSIONS****Height** 55mm **Width** 300mm **Depth** 510mm

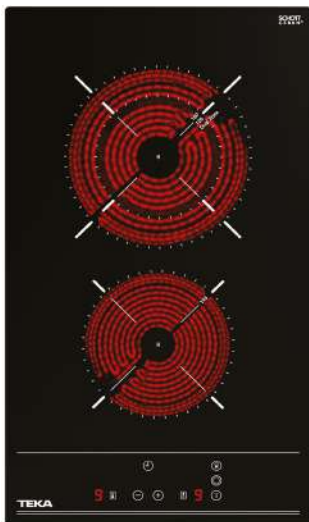

Ref. 112540002

TOTAL TZC 32320 BK TTC



- Modular vitroc ceramic hob
- Touch Control
- 2 cooking zones:
 - 1 double high light Ø 120/180
 - 1 high light Ø 145 mm
- Keep warm function
- Maximum nominal power: 2.900 W

COLOR

 Black Glass

FRAME Front bevelled glass

PRODUCT DIMENSIONS

Height 55mm **Width** 300mm **Depth** 510mm



Ref. 40214406

EASY EFX 30.1 2H

- Modular vitroc ceramic hob
- Metallic and glossy black looking frontal knob
- Residual heat indicator
- 2 cooking zones:
 - 1 high light Ø 180 mm
 - 1 high light Ø 145 mm
- Max. nominal power: 3000 W
- Optional: junction kit

COLOR

 Stainless Steel

PRODUCT DIMENSIONS

Height 40mm **Width** 305mm **Depth** 510mm



Ref. 40214451

TOTAL EFX 30.1 FRYER

- Modular hob
- Fryer
- Stainless steel surface
- Overheating cut-off system
- Metallic and glossy black looking frontal knob
- Thermostat for a constant oil temperature control
- 2 electric resistance
- Max.nominal power: 2300 W

COLOR

■ Stainless Steel

PRODUCT DIMENSIONS

Height 45mm **Width** 305mm **Depth** 510mm



Ref. 40214561

TOTAL EFX 30.1 GRILL

- Modular hob
- Barbecue
- Stainless steel surface
- Cast iron grid
- Metallic and glossy black looking frontal knob
- Overheating cut-off system
- 1 electric resistance
- Max.nominal power: 2400 W

COLOR

■ Stainless Steel

PRODUCT DIMENSIONS

Height 45mm **Width** 305mm **Depth** 510mm



Model	IZS 97630	IZF 96700	DirectSense IZF 68700	IZC 64010 BK MSS	IBF 64 Infinity G1
BUILT-IN DIMENSIONS					
Width (mm)	860	860	560	560	560
Depth (mm)	490	490	490	490	490
Height (mm)	49	49	53	50	49
COOKING ELEMENTS					
COOKING ZONE -left front , (Type)	Single Zone	-	Flex Zone	Single Zone	FlexZone
COOKING ZONE -left center , (Type)	-	Single Zone	-	-	-
COOKING ZONE -left rear , (Type)	Single Zone	-	Flex Zone	Single Zone	FlexZone
COOKING ZONE - center front , (Type)	-	-	-	-	-
COOKING ZONE -center center , (Type)	Double Zone	Single Zone	-	-	-
COOKING ZONE -center rear , (Type)	-	-	-	-	-
COOKING ZONE -right front, (Type)	Flex Zone	Flex Zone	Flex Zone	Single Zone	FlexZone
COOKING ZONE -right center, (Type)	-	-	-	-	-
COOKING ZONE -right rear, (Type)	Flex Zone	Flex Zone	Flex Zone	Single Zone	FlexZone
COOKING ZONE -left front , mm	150	-	262.5 x 195	150	235 X 188,5
COOKING ZONE -left center , mm	-	280	-	-	-
COOKING ZONE -left rear , mm	215	-	262.5 x 195	185	235 X 188,5
COOKING ZONE -center front . mm	-	-	-	-	-
COOKING ZONE -center center, mm	320 / 180	185	-	-	-
COOKING ZONE -center rear , mm	-	-	-	-	-
COOKING ZONE -right front, mm	228 x 200	228 x 200	262.5 x 195	185	235 X 188,5
COOKING ZONE -right center, mm	-	-	-	-	-
COOKING ZONE -right rear , mm	228 x 200	228 x 200	262.5 x 195	150	235 X 188,5
COOKING ZONE -left front, (W)	1200 - 1600	-	2400 - 3700	1200-1500	1750-2200
COOKING ZONE -left center, (W)	-	2100 - 3000	-	-	-
COOKING ZONE -left rear, (W)	2100 - 3000	-	2400 - 3700	1700-2100	1750-2200
COOKING ZONE -center front, (W)	-	-	-	-	-
COOKING ZONE -center center, (W)	2500 - 3600	1200 - 1600	-	-	-
COOKING ZONE -center rear, (W)	-	-	-	-	-
COOKING ZONE -right front, (W)	1750 - 2000	1750 - 2000	2400 - 3700	1700-2100	1750-2200
COOKING ZONE -right center, (W)	-	-	-	-	-
COOKING ZONE -right rear, (W)	1750 - 2000	1750 - 2000	2400 - 3700	1200-1500	1750-2200
ELECTRICAL FEATURES					
Maximum Nominal Power (W)(Induction or VTC)	10800	7200	7400	7200	7200
Maximum Nominal Power (W) (Gas)	-	-	-	-	-
Wire lenght (cm)	110	110	110	110	110
SAFETY SYSTEMS					
Child lock	✓	✓	✓	✓	✓
Automatic safety disconnection	✓	✓	✓	✓	✓
Residual heat indicator	✓	✓	✓	✓	✓

Model	TR 951	TT 6420	TBC 63632 TTC BK	TBC 64000 XFL	JZC 96342 BBB
BUILT-IN DIMENSIONS					
Width (mm)	860	605	560	580	860
Depth (mm)	490	515	490	492	490
Height (mm)	63	51	60	60	50
COOKING ELEMENTS					
COOKING ZONE -left front , (Type)	Single High Light	Single High Light	Single High Light	Single High Light	DOUBLE RING
COOKING ZONE -left center , (Type)	-	-	-	-	-
COOKING ZONE -left rear , (Type)	Double High Light	Double High Light	Single High Light	Single High Light	SEMIRAPID
COOKING ZONE - center front , (Type)	-	-	-	-	AUXILIARY
COOKING ZONE -center center , (Type)	Triple High Light	-	-	-	-
COOKING ZONE -center rear , (Type)	-	-	-	-	RAPID
COOKING ZONE -right front , (Type)	Single High Light	Single High Light	-	Single High Light	Single Zone
COOKING ZONE -right center , (Type)	-	-	-	-	-
COOKING ZONE -right rear , (Type)	Single High Light	Single High Light	Triple High Light	Single High Light	Single Zone
COOKING ZONE -left front , mm	145	145	160	180	-
COOKING ZONE -left center , mm	-	-	-	-	-
COOKING ZONE -left rear , mm	120 / 180	180 / 210	145	145	-
COOKING ZONE -center front , mm	-	-	-	-	-
COOKING ZONE -center center , mm	145 / 210 / 270	-	-	-	-
COOKING ZONE -center rear , mm	-	-	-	-	-
COOKING ZONE -right front , mm	180	145	-	145	180
COOKING ZONE -right center , mm	-	-	-	-	-
COOKING ZONE -right rear , mm	160	180	210 / 260 / 320	180	145
COOKING ZONE -left front , (W)	1200	1200	1500	1800	4000
COOKING ZONE -left center , (W)	-	-	-	-	-
COOKING ZONE -left rear , (W)	700 - 1700	1400 - 2000	1200	1200	1750
COOKING ZONE -center front , (W)	-	-	-	-	1000
COOKING ZONE -center center , (W)	1050 - 1950 - 2700	-	-	-	-
COOKING ZONE -center rear , (W)	-	-	-	-	2800
COOKING ZONE -right front , (W)	1800	1200	-	1200	1250-1800
COOKING ZONE -right center , (W)	-	-	-	-	-
COOKING ZONE -right rear , (W)	1500	1800	2000-3000-4000	1800	2250-3000
ELECTRICAL FEATURES					
Maximum Nominal Power (W)(Induction or VTC)	8900	6200	6700	6000	3500
Maximum Nominal Power (W) (Gas)	-	-	-	-	9550
Wire lenght (cm)	110	100	110	110	110
SAFETY SYSTEMS					
Child lock	√	√	√	-	√
Automatic safety disconnection	√	√	√	-	√
Residual heat indicator	√	√	√	√	√

Model	GZC 95320	GBC 75 Infinity G1	JZC 64322 ABB	GZC 64300	GZC 64320	EW 90 5G AI AL TR CI
BUILT-IN DIMENSIONS						
Width (mm)	850	570	560	570	570	845
Depth (mm)	480	480	490	480	480	495
Height (mm)	50	49	55	50	50	70
COOKING ELEMENTS						
COOKING ZONE -left front , (Type)	-	SEMIRAPID	AUXILIARY	SEMIRAPID	DOUBLE RING	SEMIRAPID
COOKING ZONE -left center , (Type)	DOUBLE RING	-	-	-	-	-
COOKING ZONE -left rear , (Type)	-	SEMIRAPID	RAPID	SEMIRAPID	SEMIRAPID	RAPID
COOKING ZONE - center front , (Type)	SEMIRAPID	-	-	-	-	AUXILIARY
COOKING ZONE -center center , (Type)	-	DOUBLE RING	-	-	-	-
COOKING ZONE -center rear , (Type)	SEMIRAPID	-	-	-	-	SEMIRAPID
COOKING ZONE -right front , (Type)	AUXILIARY	AUXILIARY	Single Zone	AUXILIARY	AUXILIARY	-
COOKING ZONE -right center , (Type)	-	-	-	-	-	TRIPLE RING
COOKING ZONE -right rear , (Type)	RAPID	RAPID	Single Zone	RAPID	RAPID	-
COOKING ZONE -left front , mm	-	-	-	-	-	-
COOKING ZONE -left center , mm	-	-	-	-	-	-
COOKING ZONE -left rear , mm	-	-	-	-	-	-
COOKING ZONE -center front , mm	-	-	-	-	-	-
COOKING ZONE -center center , mm	-	-	-	-	-	-
COOKING ZONE -center rear , mm	-	-	-	-	-	-
COOKING ZONE -right front , mm	-	-	145	-	-	-
COOKING ZONE -right center , mm	-	-	-	-	-	-
COOKING ZONE -right rear , mm	-	-	210	-	-	-
COOKING ZONE -left front , (W)	-	1400	1000	1400	4000	-
COOKING ZONE -left center , (W)	4000	-	-	-	-	-
COOKING ZONE -left rear , (W)	-	1750	2800	1750	1750	-
COOKING ZONE -center front , (W)	1400	-	-	-	-	-
COOKING ZONE -center center , (W)	-	3500	-	-	-	-
COOKING ZONE -center rear , (W)	1750	-	-	-	-	-
COOKING ZONE -right front , (W)	1000	1000	1250-1800	1000	1000	-
COOKING ZONE -right center , (W)	-	-	-	-	-	-
COOKING ZONE -right rear , (W)	2800	2800	2250-3000	2800	2800	-
ELECTRICAL FEATURES						
Maximum Nominal Power (W)(Induction or VTC)	-	-	3500	-	-	-
Maximum Nominal Power (W) (Gas)	10950	10450	3800	6950	9550	1100
Wire lenght (cm)	-	100	110	-	-	-
SAFETY SYSTEMS						
Child lock	-	-	√	-	-	-
Automatic safety disconnection	√	√	√	-	-	√
Residual heat indicator	-	-	-	-	-	-

Model	EFX 90.1 5G AI AL DR LEFT	X 90.1 5G AI AL DR CI LEFT	EFX 60.1 4G AI AL DR CI	EX 60.1 4G AI AL DR CI LEFT	HLX 640 KB
BUILT-IN DIMENSIONS					
Width (mm)	833	833	553	553	553
Depth (mm)	475	475	473	473	473
Height (mm)	45	33	45	33	38
COOKING ELEMENTS					
COOKING ZONE -left front , (Type)	-	-	DOUBLE RING	AUXILIARY	RAPID
COOKING ZONE -left center , (Type)	DOUBLE RING	DOUBLE RING	-	-	-
COOKING ZONE -left rear , (Type)	-	-	SEMIRAPID	SEMIRAPID	SEMIRAPID
COOKING ZONE - center front , (Type)	AUXILIARY	SEMIRAPID	-	-	-
COOKING ZONE -center center , (Type)	-	-	-	-	-
COOKING ZONE -center rear , (Type)	SEMIRAPID	SEMIRAPID	-	-	-
COOKING ZONE -right front, (Type)	SEMIRAPID	AUXILIARY	AUXILIARY	SEMIRAPID	AUXILIARY
COOKING ZONE -right center, (Type)	-	-	-	-	-
COOKING ZONE -right rear, (Type)	RAPID	RAPID	SEMIRAPID	RAPID	SEMIRAPID
COOKING ZONE -left front , mm	-	-	-	-	-
COOKING ZONE -left center , mm	-	-	-	-	-
COOKING ZONE -left rear , mm	-	-	-	-	-
COOKING ZONE -center front , mm	-	-	-	-	-
COOKING ZONE -center center, mm	-	-	-	-	-
COOKING ZONE -center rear , mm	-	-	-	-	-
COOKING ZONE -right front, mm	-	-	-	-	-
COOKING ZONE -right center, mm	-	-	-	-	-
COOKING ZONE -right rear , mm	-	-	-	-	-
COOKING ZONE -left front, (W)	-	-	4000	1000	3000
COOKING ZONE -left center, (W)	4000	4000	-	-	-
COOKING ZONE -left rear, (W)	-	-	1750	1750	1750
COOKING ZONE -center front, (W)	1000	1750	-	-	-
COOKING ZONE -center center, (W)	-	-	-	-	-
COOKING ZONE -center rear, (W)	1750	1750	-	-	-
COOKING ZONE -right front, (W)	1750	1000	1000	1750	1000
COOKING ZONE -right center, (W)	-	-	-	-	-
COOKING ZONE -right rear, (W)	3000	2800	1750	2800	1750
ELECTRICAL FEATURES					
Maximum Nominal Power (W)(Induction or VTC)	-	-	-	-	-
Maximum Nominal Power (W) (Gas)	11500	11300	8500	7300	7500
Wire lenght (cm)	-	-	-	-	100
SAFETY SYSTEMS					
Child lock	-	-	-	-	-
Automatic safety disconnection	√	-	√	√	√
Residual heat indicator	-	-	-	-	-

Model	IZS 34700	TZC 32320 BK TTC	EFX 30.1 2H	GZC 32309
BUILT-IN DIMENSIONS				
Width (mm)	280	270	282	280
Depth (mm)	490	500	482	490
Height (mm)	49	55	45	49
COOKING ELEMENTS				
COOKING ZONE -left front , (Type)	-	-	-	-
COOKING ZONE -left center , (Type)	-	-	-	-
COOKING ZONE -left rear , (Type)	-	-	-	-
COOKING ZONE -center front , (Type)	Flex Zone	Single High Light	Single High Light	AUXILIARY
COOKING ZONE -center center , (Type)	-	-	-	-
COOKING ZONE -center rear , (Type)	Flex Zone	Double High Light	Single High Light	SEMIRAPID
COOKING ZONE -right front, (Type)	-	-	-	-
COOKING ZONE -right center, (Type)	-	-	-	-
COOKING ZONE -right rear, (Type)	-	-	-	-
COOKING ZONE -left front , mm	-	-	-	-
COOKING ZONE -left center , mm	-	-	-	-
COOKING ZONE -left rear , mm	-	-	-	-
COOKING ZONE -center front , mm	225 x 200	145	145	-
COOKING ZONE -center center, mm	-	-	-	-
COOKING ZONE -center rear , mm	225 x 200	120 / 180	180	-
COOKING ZONE -right front, mm	-	-	-	-
COOKING ZONE -right center, mm	-	-	-	-
COOKING ZONE -right rear , mm	-	-	-	-
COOKING ZONE -left front, (W)	-	-	-	-
COOKING ZONE -left center, (W)	-	-	-	-
COOKING ZONE -left rear, (W)	-	-	-	-
COOKING ZONE -center front, (W)	1750 - 2000	1200	1200	1000
COOKING ZONE -center center, (W)	-	-	-	-
COOKING ZONE -center rear, (W)	1750 - 2000	700 - 1700	1800	1750
COOKING ZONE -right front, (W)	-	-	-	-
COOKING ZONE -right center, (W)	-	-	-	-
COOKING ZONE -right rear, (W)	-	-	-	-
ELECTRICAL FEATURES				
Maximum Nominal Power (W)(Induction or VTC)	3600	2900	3000	-
Maximum Nominal Power (W) (Gas)	-	-	-	2750
Wire lenght (cm)	110	110	100	110
SAFETY SYSTEMS				
Child lock	-	✓	-	-
Automatic safety disconnection	✓	✓	✓	✓
Residual heat indicator	✓	✓	✓	-

Model	EFX 30.1 2G AI AL CI	YZC 32600	EFX 30.1 FRYER	EFX 30.1 GRILL
BUILT-IN DIMENSIONS				
Width (mm)	280	280	282	282
Depth (mm)	490	490	482	482
Height (mm)	37	75	160	160
COOKING ELEMENTS				
COOKING ZONE -left front , (Type)	-	-	-	-
COOKING ZONE -left center , (Type)	-	-	-	-
COOKING ZONE -left rear , (Type)	-	-	-	-
COOKING ZONE - center front , (Type)	AUXILIARY	-	-	-
COOKING ZONE -center center , (Type)	-	-	-	-
COOKING ZONE -center rear , (Type)	RAPID	-	-	-
COOKING ZONE -right front, (Type)	-	-	-	-
COOKING ZONE -right center, (Type)	-	-	-	-
COOKING ZONE -right rear, (Type)	-	-	-	-
COOKING ZONE -left front , mm	-	-	-	-
COOKING ZONE -left center , mm	-	-	-	-
COOKING ZONE -left rear , mm	-	-	-	-
COOKING ZONE -center front , mm	-	-	-	-
COOKING ZONE -center center, mm	-	-	-	-
COOKING ZONE -center rear , mm	-	-	-	-
COOKING ZONE -right front, mm	-	-	-	-
COOKING ZONE -right center, mm	-	-	-	-
COOKING ZONE -right rear , mm	-	-	-	-
COOKING ZONE -left front, (W)	-	-	-	-
COOKING ZONE -left center, (W)	-	-	-	-
COOKING ZONE -left rear, (W)	-	-	-	-
COOKING ZONE -center front, (W)	1000	-	-	-
COOKING ZONE -center center, (W)	-	-	-	-
COOKING ZONE -center rear, (W)	3000	-	-	-
COOKING ZONE -right front, (W)	-	-	-	-
COOKING ZONE -right center, (W)	-	-	-	-
COOKING ZONE -right rear, (W)	-	-	-	-
ELECTRICAL FEATURES				
Maximum Nominal Power (W) (Induction or VTC)	-	2400	2300	2400
Maximum Nominal Power (W) (Gas)	1100	-	-	-
Wire lenght (cm)	100	100	135	135
SAFETY SYSTEMS				
Child lock	-	-	-	-
Automatic safety disconnection	√	-	√	√
Residual heat indicator	-	-	-	-

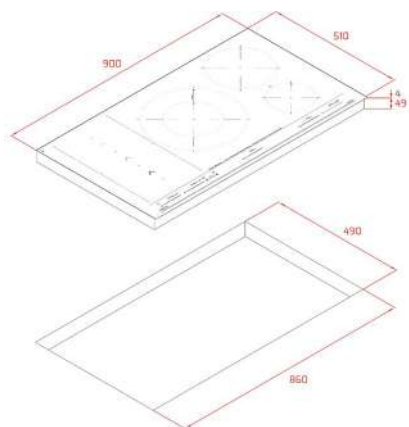

IZS 97630

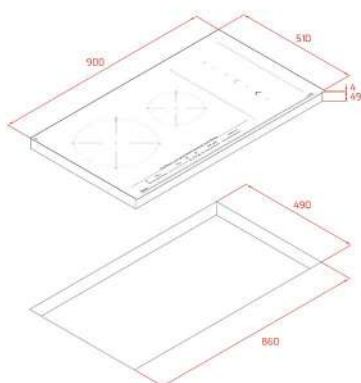

IZS 96700

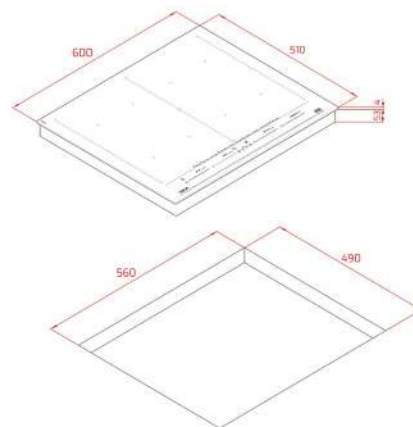

IZF 68700

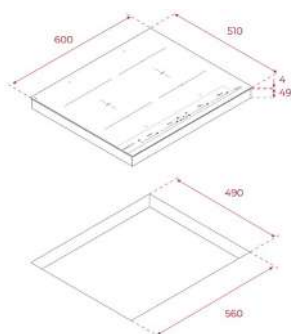

IBF 64 INFINITY G1

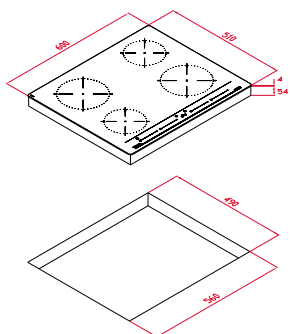

IZC 64010 BK MSS

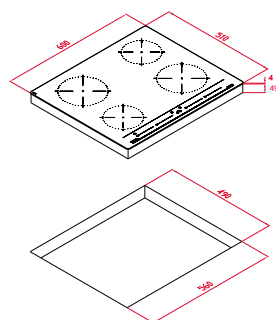

IZC 64630

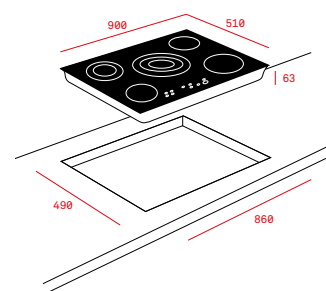

TR 951

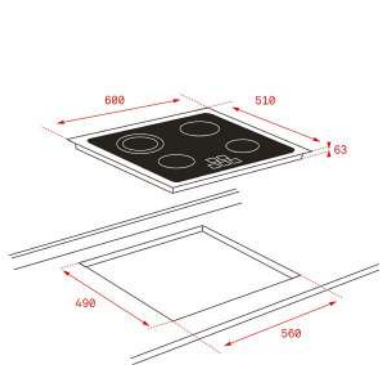

TT 6420

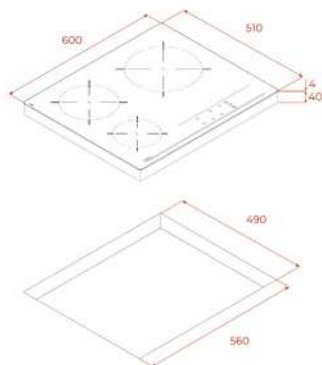

TBC 63632

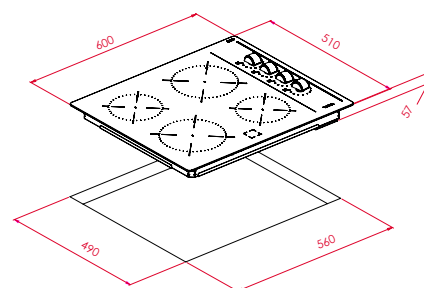

TBC 64000 XFL

HOBBS

INSTALLATION DIAGRAM

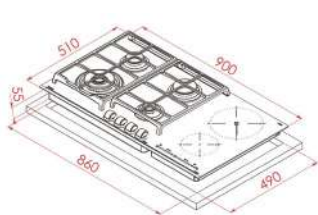

JZC 96342 BBB

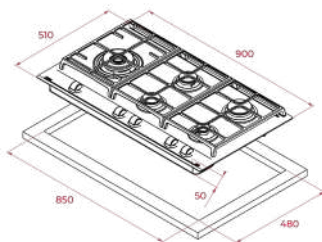

GZC 95320

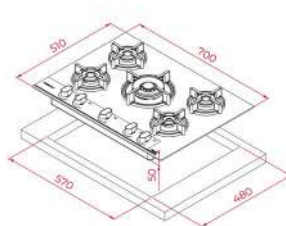

GBC 75 INFINITY G1

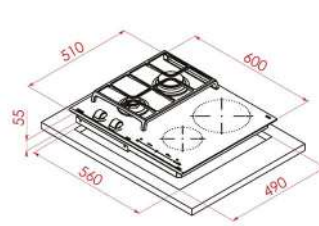

JZC 64322 ABB

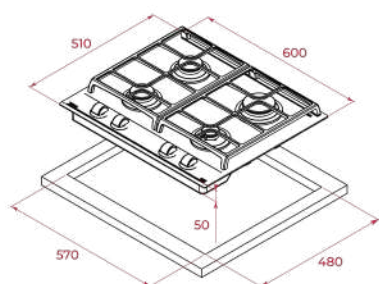

GZC 64300

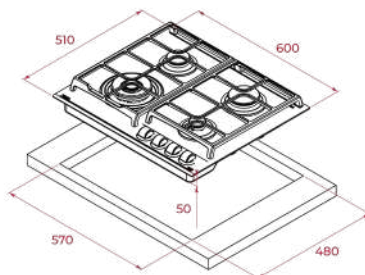

GZC 64320

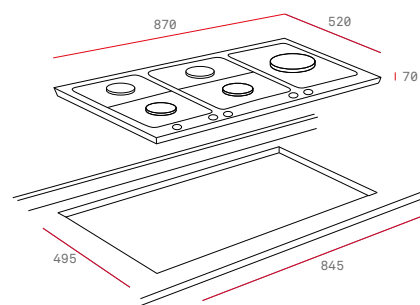

EW 90 5G AI AL TR CI

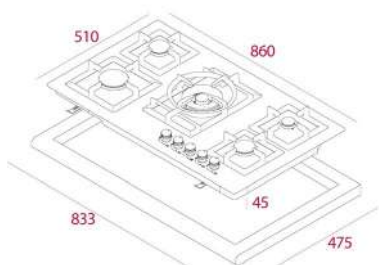

EFX 90.1 5G AI AL DR LEFT

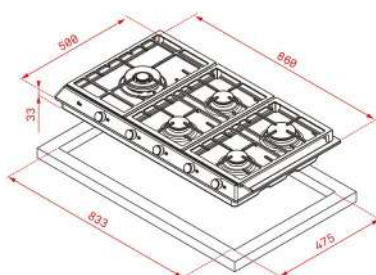

EX 90.1 5G AI AL DR CI LEFT

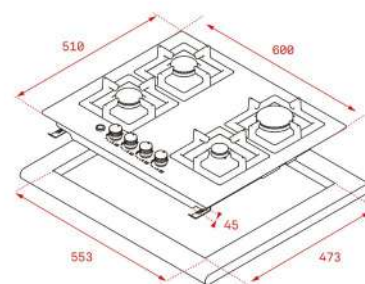

EFX 60.1 4G AI AL DR CI

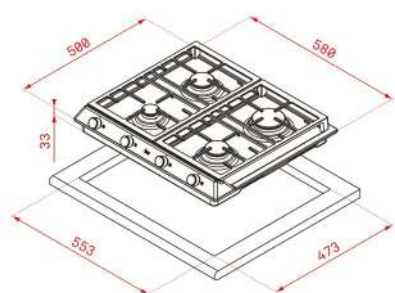

EX 60.1 4G AI AL DR CI

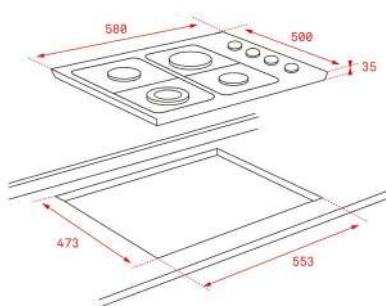

HLX 640 KB

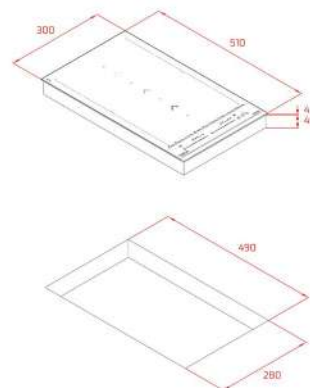

IZS 34700

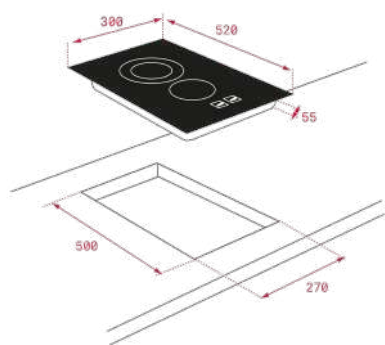

TZC 32320 BK TTC

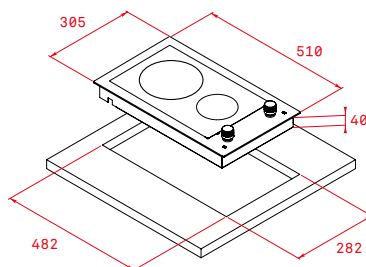

EFX 30.1 2H

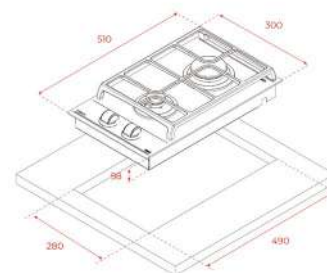

GZC 32309

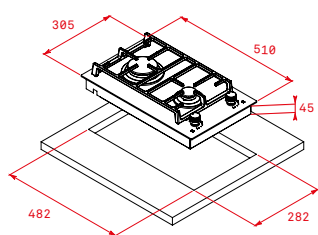

EFX 30.1 2G AI AL CI

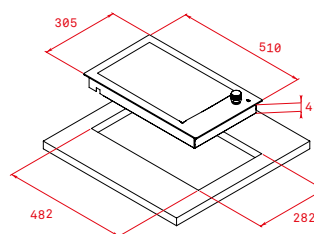

YZC 32600, EFX 30.1 GRILL
EFX 30.1 FRYER



Free Standing Cookers

Turning great cooking experiences
into memorables moments

FS COOKER



SCAN AND
DISCOVER

FS COOKER



Ref. 40297055

MAESTRO FS3FF L90GG S/S

- Free Standing Cooker 90cm
- Gas hob/ Multifunction gas oven
- Color: Inox
- Auto ignition
- Autolock safety device
- Drawer
- Nozzels to natural gas

Hob Features:

- Stainless steel surface
- Cast irons
- 5 Gas Burners:
 - 1 Triple ring: 4 kW, 2 Semi-Rapid: 1,75 kW
 - 1 Auxiliary burner: 1 kW, 1 Rapid: 3 kW
- Steel upstand

Oven Features:

- Multifunction strip with safety thermostat
- Gas grill
- Close door grilling
- 4 Cooking functions, Oven light
- Touch control programmer with start/stop
- 1 telescopic guide
- Chromed supports
- 5 cooking levels
- Full glass inner door
- Double glazed door
- 2 Deep tray
- Chromed grid
- Inner grid
- Gross capacity: 142 liters

COLOR

■ Stainless Steel

PRODUCT DIMENSIONS

Height 875-920mm Width 895mm Depth 600mm



Ref. 40297953

EASY FS 901 5GE SS LPG

- Free Standing Cooker 90cm
- Gas hob/ Multifunction electric oven
- Color: Inox
- Metallic painted knob
- Auto ignition, Autolock safety device
- Adjustable feet With G plug
- Drawer, Nozzels to natural gas
- Telescopic legs

Hob Features:

- Stainless steel surface
- Cast irons
- 5 Gas Burners:
 - 1 Triple ring: 3,5 kW, 2 Semi-Rapid: 1,7 kW
 - 1 Auxiliary burner: 0,95 kW, 1 Rapid: 2,9 kW
- Sabaf burners

Oven Features:

- Multifunction Oven
- Net/Gross capacity: 100/119l
- 7 Cooking functions
- Turbo fan, Close door grilling
- Digital timer with start/stop
- 1 telescopic guide
- Chromed supports
- Catalitic side panels
- 4 cooking levels
- Full glass, double glazed door, Deep tray
- Chromed grid, Turnspit, Cooling fan, Light
- Energy class: A

COLOR

■ Stainless Steel

PRODUCT DIMENSIONS

Height 845mm Width 900mm Depth 635mm



Ref. 40297954

EASY FS 902 5GG SS LPG

- Free Standing Cooker 90cm
- Gas hob/ Gas oven
- Color: Inox,
- Metallic painted knob
- Handle in Stainless steel
- Auto ignition
- Autolock safety device
- Telescopic legs
- With G plug
- Flap tape
- Nozzels to natural gas

Hob Features:

- Stainless steel surface
- Cast irons
- 5 Gas Burners:
 - 1 Triple ring: 3,5 kW, 2 Semi-Rapid: 1,7 kW
 - 1 Auxiliary burner: 0,95 kW, 1 Rapid: 2,9 kW
- Glass lid
- Sabaf burbers

Oven Features:

- Gas oven, Close door grilling
- Net/Gross capacity: 106/119l
- 3 Cooking functions, Mechanical timer
- 1 telescopic guide, Chromed supports
- 4 cooking levels, Catalytic side panels
- Full glass, double glazed door
- Deep tray, Chromed grid
- Turnspit
- Light

COLOR

 Stainless Steel

PRODUCT DIMENSIONS

Height 845mm **Width** 900mm **Depth** 635mm



Ref. 40297955

EASY FS 903 5VE SS

- Free Standing Cooker 90cm
- Vitroc ceramic hob/ Multifunction electric oven
- Color: Inox
- Metallic painted knob
- Handle in Stainless steel
- Telescopic legs
- Lid flape
- Kado box with cable

Hob Features:

- Vitroc ceramic
- Hob surface in stainless steel
- 5 heating elements:
 - 2xØ180 1800W, 2xØ140 1200W
 - 1xØ140-250 1800W

Oven Features:

- Multifunction electric oven
- Closed door grilling
- Net/Gross capacity: 100/119l
- 8 cooking functions
- Turbo fan, Close door grilling
- Digital timer with start stop
- 1 telescopic guide
- Chromed supports
- 4 cooking levels
- Catalitic side panels
- Full glass inner door with 2 glazed removable
- Deep tray, Cooking grid, Turnspit
- Cooling fan, Light
- Energy class: B

COLOR

 Stainless Steel

PRODUCT DIMENSIONS

Height 845mm **Width** 900mm **Depth** 633mm

FS COOKER

TECHNICAL FEATURES

MODEL	FS3FF L90GG S/S	FS 901 5GE SS LPG	FS 902 5GG SS LPG	FS 903 5VE SS
PRODUCT DIMENSIONS				
Width (mm)	895	900	900	900
Depth (mm)	600	635	635	635
Height (mm)	875-920	845	845	845
ELECTRICAL CONNECTION				
Power Rate, V	230	220-240	220-240	220-240
Frequency, Hz	50	50	50-60	50-60
Connecting Wire (cm)	200	150 cm + Plug	150 cm + Plug	Kado Box + Cable
Maximum Nominal Power, W	30	3600	0	11400
OVEN ELECTRICAL FEATURES				
Maximum Nominal Power, W	55	3600	-	3600
Bottom Heating Element, W	-	2000	-	2000
Grill/Maxigrill, W	-	1500/2500	-	1500/2500
Turnspit Motor, W	-	6	6	6
Light, W	25	15	15	15
Cooling Fan Motor, W	-	24	24	24
OVEN GAS FEATURES				
Bottom Burner, W	4500	-	4000	-
Grill Burner, W	2000	-	2700	-
HOB ELECTRICAL FEATURES				
Maximum Nominal Power, W	-	-	-	7800
Heating Element Ø/ W	-	-	-	2xØ180 1800W
Heating Element Ø/ W	-	-	-	2xØ140 1200W
Heating Element Ø/ W	-	-	-	1xØ140-250 1800W
HOB GAS FEATURES				
Maximum Nominal Power, W	11.5 kW	10.75 kW	10.75 kW	-
A. Triple Ring, kW	4 kW	3.5 kW	3.5 kW	-
B. Fast Burner, kW	3 kW	2.9 kW	2.9 kW	-
C. Semifast Burner, kW	1.75 kW (2)	1.7 kW (2)	1.7 kW (2)	-
D. Auxiliary Burner, kW	1 kW	0.95 kW	0.95 kW	-
OVEN FEATURES				
Net / Gross Capacity (Litres)	142	100/119	106/119	100/119
Cooking Functions	5	7	3	8
Digital Timer With Start/Stop Programmer	-	Yes	-	Yes
Digital Timer	Touch	-	-	-
Mechanical Timer With Stop Programmer	-	-	Yes	-
Cooking Levels	5	4	4	4
Close Door Grilling	Yes	Yes	Yes	Yes
Telescopic Tray Guides	1	1	1	1
Chromed Tray Guides	Yes	Yes	Yes	Yes
Glazed Door	2 Full Glass	2 Full Glass	2 Full Glass	2 Full Glass
Self-Cleaning Panels	-	Side Catalitic Panel	Side Catalitic Panel	Side Catalitic Panel
Baking Tray	-	-	-	-
Deep Tray	2	1	1	1
Standard Cooking Grid	1	1	1	1
Inner Grid	1	-	-	-
Turnspit	-	Yes	Yes	Yes
Drawer	Yes	Lid Flape	Lid Flape	Lid Flape
Energy Class	-	B	-	B
HOB FEATURES				
Hob Surface	SS Squared	SS	SS	SS
Grids	Cast Iron	Cast Iron	Cast Iron	-
Autolock (Safety Device)	Yes	Yes	Yes	-
Auto-Ignition	Yes	Yes	Yes	-
Other Special Accesories	Steel Upstand	Glass Lid	Glass Lid	-
FINISH				
Colour (Front)	Black	Stainless Steel	Stainless Steel	Stainless Steel
Door Glass Color	Black	Black	Black	Black

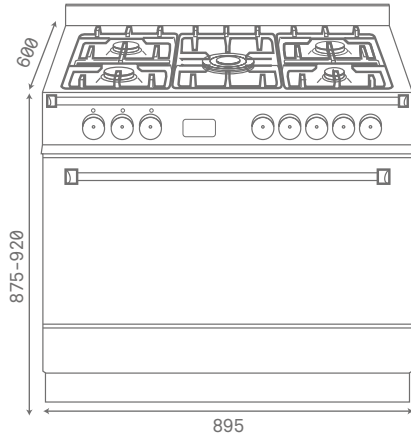

FS3FF L90GG 5/S

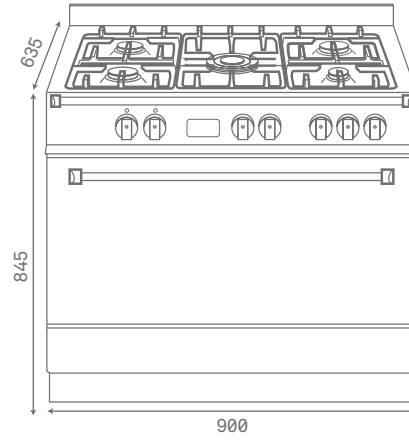

FS 901 5GE SS LPG

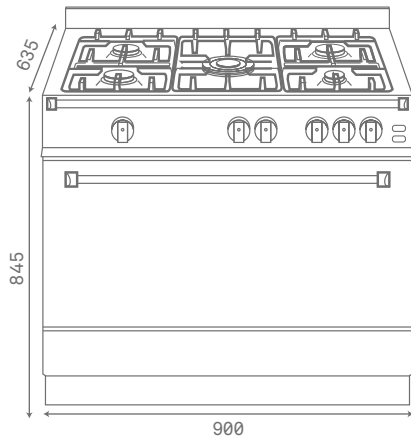

FS 902 5GG SS LPG

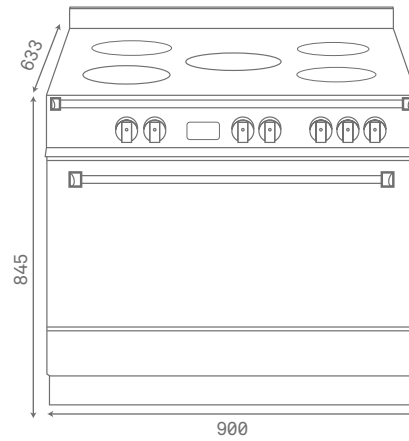

FS 903 5VE SS

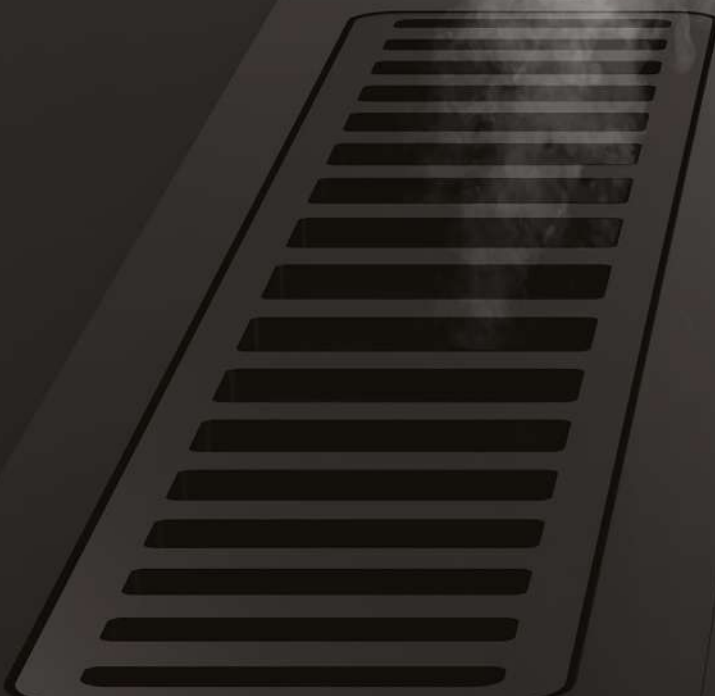

Control panel featuring a digital display showing '2', a minus sign button, a plus sign button, a lock icon with '(3s)', a power button, a timer icon with '(3s)', and a 'FRESH (3s)' icon.

 Simmering

TEKA

Hoods

Welcome the fresh air into your kitchen



HOODS

WORLDWIDE **NOVELTY**

Infinity | G1 Edition

ELEGANCE AND PERFORMANCE AT ITS BEST

Our new Infinity | G1 Edition Vertical Hood is so good looking, that it will simply blend into your kitchen like a piece of decoration.

With powerful extraction and discreet, yet functional illumination, our Infinity | G1 Edition Hood will prove its worth and capability to turn performance and fresh air into an easily achievable goal, while maintain harmony in your kitchen look and layout.



Unique finishing

Its black matt and velvet finishing, make it unique and special, ready to complement any kitchen, adding a touch of fine taste.



Efficiency and performance

A+ energy efficiency class, with up to 800 m³/h max speed exhaust capacity.



Convenience and flexibility

Up to four optional recirculation types of possible installation.



Discover the complete edition

Get the most out of your Infinity | G1 Edition Vertical Hood, by matching them with the rest of the products of the edition.



HOODS



SCAN AND
DISCOVER

Meet the new Ceiling hood

DISCRETION AND HIGH
PERFORMANCE AT ITS BEST.

Our ceiling hood is as discreet as it gets. Discover all the possibilities with its FreshAir Function, which will always keep your kitchen fresh and odour-free with automatic extraction cycles that you can program.

Moreover, control its light intensity and colour temperature to create an even nicer atmosphere, while keeping low noise and high efficiency. All of this and more in a hood equipped to be easily installed, so that you will have no worries















EXTERNAL EXTRACTION OR
RECIRCULATION,
THE CHOICE IS YOURS

Depending on your needs and home design, you will have the option to install your ceiling hood with recirculation system, which will aspire the odours and bring fresh air back into your kitchen, or with direct external extraction, which will take the odours out of your home.



Hoods

Kitchen goes way beyond just preparing food.

MAESTRO						
	FLOW-IN	110	90	70/60/50		
ISLAND	 FIH 16760 T05 BK	 DPL 1185 ISLAND	 DHT 97670 ROS WH	 DH2 985 ISLAND		
VERTICAL			 DVI 88-G1 E05 BM	 DLV 98660	 DVT 98660	 DLV 68660
GLASS WING						
HORIZONTAL			 PERFECTA4 DLH 985 T			
PYRAMIDAL						
BUILT-IN				 GEL 77760 E05 IX	 GFL 57651 E05 BK	
PULL OUT						
CLASSIC						

MAESTRO

Domestic appliances for those who like going one step further. For those who will not settle for being like the rest.

TOTAL

Designed for those who demand everything of their appliances, for everyone in the house. Maximum effectiveness in any situation.

EASY

For those who prefer no complications in the kitchen without denying themselves an appliance that gives so much while asking for so little in return.

TOTAL			EASY	
90	70/60	55	90	70/60



DG3 985 ISLAND



NC 980



NC 680



DSH 985



DSJ 980



DBB 90 HP



DBB 90



DBB 60



GFH 73



GFG 2



CNL 9610



CNL 6610



TL 9310



TL 6310



C 9310



C 6310



CL 610 S/W

HOODS



Ref. 113160000

NEW

MAESTRO FIH 16760 TOS BK



- VarioPro Series
- Modular Flow-in hood
- Touch control
- FreshAir function
- Energy Efficiency Class: A+
- Brushless EcoPower Motor
- 3 speeds + 1 intensive
- Free Outlet exhaust capacity (m3/h): 630
- Intensive speed exhaust capacity (m3/h): 600
- Max speed exhaust capacity (m3/h): 540
- Min speed exhaust capacity (m3/h): 415
- Intensive speed sound level (dBA): 70
- Max speed sound level (dBA): 67
- Min speed sound level (dBA): 62
- 1 mesh washable filter
- Stop delay timer
- Filter saturation indicator
- Operating pilot light
- Optional regenerative filters

Optional **Recirculation Kits** and **Filters** for installation without outlet available in page #138

COLOR

 **Black Glass**

PRODUCT DIMENSIONS

Width 110mm



Ref. 113100004

NEW

MAESTRO DHT 97670 WHITE



- Ceiling hood
- Rim extraction
- Electronic control
- FreshAir function
- Energy Efficiency class: A++
- Remote control
- Brushless EcoPower Motor
- 4 speeds + 2 intensive
- Free Outlet exhaust capacity (m3/h): 800
- Max speed exhaust capacity (m3/h): 808
- Min speed exhaust capacity (m3/h): 315
- Intensive speed exhaust capacity (m3/h): 686
- Intensive speed sound level (dBA): 70
- Max speed sound level (dBA): 67
- Min speed sound level (dBA): 50
- 3 LED lamps
- Light intensity and color temperature regulation
- 2 Aluminum filter
- Stop delay timer
- Filter saturation indicator
- Operating pilot light
- Optional regenerative filters

Optional **Recirculation Kits** and **Filters** for installation without outlet available in page #138

COLOR

 **White Glass**

PRODUCT DIMENSIONS

Width 900mm



Ref. Structure: 40483173 Body: 40483172

MAESTRO DPL 1185 ISLAND



- Island hood
- Rim extraction
- EcoPower motor
- Energy Efficiency class: A
- Touch control with White display
- Operating pilot light
- 3 speeds + 1 intensive
- Exhaust capacities:
- Free Outlet, 920 m³/h
- Qboost, 782 m³/h
- Max., m³/h: 629
- Min., m³/h: 331
- Noise (LwA) Boost Speed, dB: 69
- Noise (LwA) Max Speed, dB: 66
- Noise (LwA) Min Speed, dB: 54
- 4 LED Lamps
- Reinforced black glass
- 3 aluminum filters
- Stop delay timer
- Filter saturation indicator

Optional **Recirculation Kits** and **Filters** for installation without outlet available in page #137

COLOR

 Black Glass

PRODUCT DIMENSIONS

Width 1100mm



Ref. 40484640

MAESTRO DH2 985 ISLAND



- Island hood
- EcoPower motor
- Energy Efficiency class: A
- Backlit electronic panel with white display
- Operating pilot light
- 3 speeds + 1 intensive
- Exhaust capacities:
- Free Outlet, m³/h: 920
- Qboost, m³/h: 796
- Max., m³/h: 605
- Min., m³/h: 311
- Noise (LwA) Boost Speed, dB: 71
- Noise (LwA) Max Speed, dB: 66
- Noise (LwA) Min Speed, dB: 52
- 4 LED lamps
- 3 stainless steel-aluminium filters
- Easy to clean inside panel
- Stop delay timer
- Filter saturation indicator

Optional **Recirculation Kits** and **Filters** for installation without outlet available in page #137

COLOR

 Stainless Steel

PRODUCT DIMENSIONS

Width 900mm

HOODS



Ref. 40485150

TOTAL DG3 985 ISLAND



- Glass wing island hood
- EcoPower motor
- Energy Efficiency class: A
- Backlit electronic panel with white display
- Operating pilot light
- 3 speeds + 1 intensive
- Exhaust capacities:
- Free Outlet, m³/h: 920
- Qboost, m³/h: 796
- Max., m³/h: 605
- Min., m³/h: 311
- Noise (LwA) Boost Speed, dB: 71
- Noise (LwA) Max Speed, dB: 66
- Noise (LwA) Min Speed, dB: 52
- 4 LED lamps
- 2 stainless steel filters
- Reinforced transparent glass
- Stop delay timer
- Filter Satiration indicator

Optional **Recirculation Kits** and **Filters** for installation without outlet available in page #137

COLOR

 Stainless Steel

PRODUCT DIMENSIONS

Width 900mm



Ref. 112930029

MAESTRO DLV 98660 BK

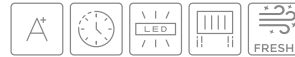

- Urban Colors Edition
- Vertical decorative hood
- Rim extraction system
- Touch control display
- FreshAir function
- Full glass design
- 3 speeds + intensive
- Stop delay timer
- LED light bar
- Saturation filter indicator
- EcoPower motor
- Exhaust capacity: min.290 m³/h - max.696 m³/h
- Sound level: min.51 dB - max.67 dB
- Installation also possible without tube cover

Optional **Recirculation Kits** and **Filters** for installation without outlet available in page #137 - 138

COLOR

 Black Glass

PRODUCT DIMENSIONS

Width 900mm

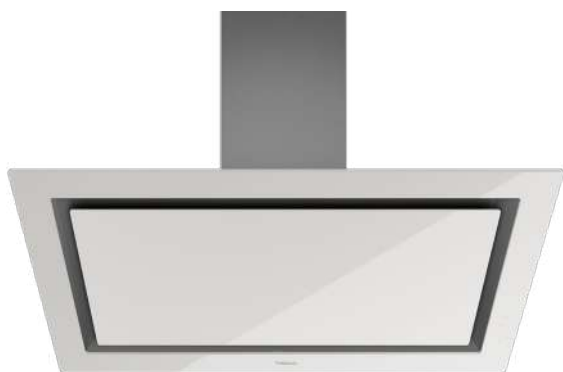

Ref. 112930030

MAESTRO DLV 98660 WH

- Urban Colors Edition
- Vertical decorative hood
- Rim extraction system
- Touch control display
- FreshAir function
- Full glass design
- 3 speeds + intensive
- Stop delay timer
- LED light bar
- Saturation filter indicator
- EcoPower motor
- Exhaust capacity: min.290 m3/h - max.696 m3/h
- Sound level: min.51 dB - max.67 dB
- Installation also possible without tube cover

Optional **Recirculation Kits** and **Filters** for installation without outlet available in page #137 - 138

COLOR
 White Glass
PRODUCT DIMENSIONS**Width** 900mm

Ref. 112930033

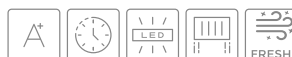
MAESTRO DLV 98660 ST

- Urban Colors Edition
- Vertical decorative hood
- Rim extraction system
- Touch control display
- FreshAir function
- Full glass design
- 3 speeds + intensive
- Stop delay timer
- LED light bar
- Saturation filter indicator
- EcoPower motor
- Exhaust capacity: min.290 m3/h - max.696 m3/h
- Sound level: min.51 dB - max.67 dB
- Installation also possible without tube cover

Optional **Recirculation Kits** and **Filters** for installation without outlet available in page #137 - 138

COLOR
 Stone Grey Glass
PRODUCT DIMENSIONS**Width** 900mm



Ref. 112930043

MAESTRO DVT 98660 BK



- Vertical decorative hood
- Rim extraction system
- Touch control display
- FreshAir function
- Full glass design
- 3 speeds + intensive
- Stop delay timer
- LED illumination
- Saturation filter indicator
- EcoPower motor
- Exhaust capacity: min.307 m3/h - max.698 m3/h
- Sound level: min.61 dB - max.72 dB
- Installation also possible without tube cover

Optional **Recirculation Kits** and **Filters** for installation without outlet available in page #137 - 138

COLOR

 Black Glass

PRODUCT DIMENSIONS

Width 900mm



Ref. 112930056

NEW

MAESTRO DVI 88 INFINITY G1



- Infinity | G1 Edition
- Decorative vertical hood
- Touch control with display
- FreshAir function
- 3 speeds + 1 intensive
- Intensive speed exhaust capacity (m3/h): 696
- Max speed exhaust capacity (m3/h): 558
- Min speed exhaust capacity (m3/h): 290
- Intensive speed sound level (dBA): 69.9
- Max speed sound level (dBA): 66.5
- Min speed sound level (dBA): 51.4
- 1 LED lamp
- 2 Aluminium filters
- Stop delay timer
- Filter saturation indicator
- Anti-return valve included
- Outlet reduction included

Optional **Recirculation Kits** and **Filters** for installation without outlet available in page #137 - 138

COLOR

 Black

PRODUCT DIMENSIONS

Width 800mm



Ref. 112930024

MAESTRO DLV 68660 BK



- Urban Colors Edition
- Vertical decorative hood
- Rim extraction system
- Touch control display
- FreshAir function
- Full glass design
- 3 speeds + intensive
- Stop delay timer
- LED light bar
- Saturation filter indicator
- EcoPower motor
- Exhaust capacity: min.232 m³/h - max.725 m³/h
- Sound level: min.49 dB - max.65 dB
- Installation also possible without tube cover

Optional **Recirculation Kits** and **Filters** for installation without outlet available in page #137 - 138

COLOR

 Black Glass

PRODUCT DIMENSIONS

Width 600mm



Ref. 980: 40455332 Ref. 680: 40455330

EASY NC 980 / NC 680



- Ultraslim glass wing decorative hood
- Backlit electronic panel with white display
- Operating pilot light
- 3 speeds + 1 intensive
- Energy Efficiency class: D
- Exhaust capacities:
- Free Outlet, m³/h: 825
- Qboost, m³/h: 637
- Max., m³/h: 402, Min., m³/h: 298
- Noise (LwA) Boost Speed, dB: 70
- Noise (LwA) Max Speed, dB: 60
- Noise (LwA) Min Speed, dB: 52
- 2 LED lamps
- 1 stainless steel - aluminium filter
- Reinforced glass upper structure
- Stop delay timer
- Filter saturation indicator

Optional **Recirculation Kits** and **Filters** for installation without outlet available in page #137 - 138

COLOR

 Stainless Steel

PRODUCT DIMENSIONS

Width 900mm / 600mm

HOODS



Ref. 40437100

MAESTRO PERFECTA4 DLH 985 T



- Ultraslim decorative hood
- EcoPower motor
- Energy Efficiency class: A
- 4A (Energy efficiency A, Fluid dynamic efficiency A, lighting efficiency A, grease filtering efficiency A)
- Touch control display
- Operating Pilot Light
- 3 speeds + 1 intensive
- Exhaust capacities:
- Free Outlet, m³/h: 795
- Qboost, m³/h: 740
- Max., m³/h: 586
- Min., m³/h: 306
- Noise (LwA) Boost Speed, dB: 72
- Noise (LwA) Max Speed, dB: 68
- Noise (LwA) Min Speed, dB: 54
- 1 LED BAR
- 3 stainless steel filters (12 layers)
- Stop delay timer
- Filter saturation indicator

Optional **Recirculation Kits** and **Filters** for installation without outlet available in page #137 - 138

COLOR

■ Black Glass / ■ Stainless Steel

PRODUCT DIMENSIONS

Width 900mm



Ref. 40484202

TOTAL DSH 985



- EcoPower motor
- Electronic control
- Digital display
- LED Light Bar
- 3 speeds + 1 intensive
- Stop delay timer
- Energy Efficiency class: A
- 3 Stainless steel filters
- Filter saturation indicator
- Exhaust capacities:
- Free Outlet, m³/h: 920
- Qboost, m³/h: 735
- Max., m³/h: 586
- Min., m³/h: 305
- Noise (LwA) Boost Speed, dB: 72
- Noise (LwA) Max Speed, dB: 68
- Noise (LwA) Min Speed, dB: 54

Optional **Recirculation Kits** and **Filters** for installation without outlet available in page #137 - 138

COLOR

■ Stainless Steel

PRODUCT DIMENSIONS

Width 900mm



Ref. 40484821

EASY DSJ 980

- Ultraslim decorative hood
- Push Buttons Control Panel
- Operating Pilot Light
- Conventional Aspiration Type
- Energy Efficiency class: C
- 3 Speeds
- Exhaust capacities:
- Free Outlet (m³/h): 638
- Max. (m³/h): 614
- Min. (m³/h): 268
- Noise (LwA) Max Speed 66 dB
- Noise (LwA) Min Speed 48 dB
- Integrated LED Light
- 3 stainless Steel-aluminum Filter

Optional **Recirculation Kits** and **Filters** for installation without outlet available in page #137 - 138

COLOR

 **Stainless Steel**

PRODUCT DIMENSIONS

Width 900mm



Ref. 40460472

EASY DBB 90 HP

- Pyramidal decorative hood
- Push buttons control panel
- Operating Pilot Light
- Conventional aspiration
- Energy Efficiency class: E
- 3 speeds
- Exhaust capacities:
- Free Outlet (m³/h): 850
- Max. (m³/h): 780
- Min. (m³/h): 240
- Noise (LwA) Max Speed 56 dB
- Noise (LwA) Min Speed 48 dB
- Incandescent Lamps
- 3 aluminum filters

Optional **Recirculation Kits** and **Filters** for installation without outlet available in page #137 - 138

COLOR

 **Stainless Steel**

PRODUCT DIMENSIONS

Width 900mm

HOODS



Ref. 90: 40460440

Ref. 60: 40460400

EASY DBB 90 / DBB 60



- Pyramidal decorative hood
- Push buttons control panel
- Operating Pilot Light
- Conventional aspiration
- Energy Efficiency class 90/60: D/E
- 3 speeds
- Exhaust capacities:
- Free Outlet (m³/h): 475
- Max. (m³/h): 380
- Min. (m³/h): 234
- Noise (LwA) Max Speed 60 dB
- Noise (LwA) Min Speed 44 dB
- Incandescent Lamps
- 3/2 aluminium filters

Optional **Recirculation Kits** and **Filters** for installation without outlet available in page #137 - 138

COLOR

 Stainless Steel

PRODUCT DIMENSIONS

Width 900mm / 600mm



Ref. 9610: 40436850

Ref. 6610: 40436830

TOTAL CNL 9610 / CNL 6610



- Pull-out hood
- Electronic control panel
- 2+1 speeds
- Energy Efficiency class: C
- Exhaust capacities:
- Free Outlet, m³/h: 745
- Qboost, m³/h: 694
- Max., m³/h: 445
- Min., m³/h: 330
- Noise (LwA) Boost Speed, dB: 70,1
- Noise (LwA) Max Speed, dB: 62,6
- Noise (LwA) Min Speed, dB: 59,8
- 3/2 LED lamps
- 4/2 aluminium filters
- Automatic Lighting
- Exchangeable Front Panel
- Finger Print Proof Front Panel

Optional **Recirculation Kits** and **Filters** for installation without outlet available in page #137

COLOR

 Stainless Steel

PRODUCT DIMENSIONS

Width 900mm / 600mm



Ref. 9310: 40474390

Ref. 6310: 40474250

EASY TL 9310 / TL 6310

- Pull-out hood
- Mechanical control panel
- 2 speeds
- Energy Efficiency class: D
- Exhaust capacities:
- Free Outlet, m³/h: 366
- Max., m³/h: 332
- Min., m³/h: 233
- Noise (LwA) Max Speed, dB: 65
- Noise (LwA) Min Speed, dB: 56
- 2 Integrated LED lamps
- 4/2 aluminium filters
- Automatic Lighting
- Exchangeable Front Panel

Optional **Recirculation Kits** and **Filters** for installation without outlet available in page #137

COLOR

 Stainless Steel

PRODUCT DIMENSIONS

Width 900mm / 600mm



Ref. 9310: 40466240

Ref. 6310: 40461540

EASY C 9310 / C 6310

- Classic hood
- Push buttons control panel (SS models)
- Operating pilot light
- Energy Efficiency class: E
- 3 speeds
- Exhaust capacities:
- Free Outlet, m³/h: 254
- Max., m³/h: 235
- Min., m³/h: 124
- Noise (LwA) Max Speed, dB: 62
- Noise (LwA) Min Speed, dB: 45
- 2 Integrated halogen lamps
- 3/2 aluminium filters
- Finger Print Proof Front Panel (SS)

Optional **Recirculation Kits** and **Filters** for installation without outlet available in page #137

COLOR

 Stainless Steel

PRODUCT DIMENSIONS

Width 900mm / 600mm

HOODS



Ref. 40495271

EASY CL 610 S



- Classic hood
- Slider control panel
- Energy Efficiency class: D
- 3 speeds
- Exhaust capacities:
- Free Outlet, m³/h: 205
- Max., m³/h: 200
- Min., m³/h: 147
- Noise (LwA) Max Speed, dB: 61
- Noise (LwA) Min Speed, dB: 52
- 1 LED lamp 3W
- 2 aluminium filters

Optional **Recirculation Kits** and **Filters** for installation without outlet available in page #137

COLOR

Stainless Steel

PRODUCT DIMENSIONS

Width 600mm



Ref. 40495270

EASY CL 610 W



- Classic hood
- Slider control panel
- Energy Efficiency class: D
- 3 speeds
- Exhaust capacities:
- Free Outlet, m³/h: 205
- Max., m³/h: 200
- Min., m³/h: 147
- Noise (LwA) Max Speed, dB: 61
- Noise (LwA) Min Speed, dB: 52
- 1 LED lamp 3W
- 2 aluminium filters

Optional **Recirculation Kits** and **Filters** for installation without outlet available in page #137

COLOR

White

PRODUCT DIMENSIONS

Width 600mm



Ref. 113100008

NEW**MAESTRO GFL 7760 EOS IX**

- Built-in Hood
- Energy Efficiency class: A+
- Electronic control
- Rim extraction
- 3 + 1 speeds
- Free outlet exhaust capacity: 735 m³/h
- Intensive exhaust capacity (m³/h): 760
- Max speed exhaust capacity (m³/h): 425
- Intensive speed sound level (dBA): 70,1
- Max speed sound level (dBA): 68
- Min speed sound level (dBA): 54,4
- 2 LED Lamps
- Filters with layers
- Stop delay timer
- Anti-return valve included
- Outlet reduction included

Optional **Recirculation Kits** and **Filters** for installation without outlet available in page #137

COLOR

 **Stainless Steel**

PRODUCT DIMENSIONS

Width 712 mm



Ref. 113100005

NEW**MAESTRO GFL 57651 EOS BK**

- Built-in hood
- Energy Efficiency class: A+
- Electronic control
- Rim extraction
- 3 speeds + 1 intensive
- Free Outlet exhaust capacity (m³/h): 735
- Max speed exhaust capacity (m³/h): 738
- Intensive speed sound level (dBA): 70,1
- Max speed sound level (dBA): 68
- Min speed sound level (dBA): 54,4
- 2 LED Lamps
- 1 aluminium filter
- Stop delay timer
- Anti-return valve included
- Outlet reduction included

Optional **Recirculation Kits** and **Filters** for installation without outlet available in page #137

COLOR

 **Black Glass**

PRODUCT DIMENSIONS

Width 595 mm

HOODS



Ref. 40446710

TOTAL GFH 73

- Filter group
- Push buttons control panel
- Operating pilot light
- Conventional aspiration
- Energy Efficiency class: D
- 3 speeds
- Exhaust capacities:
- Free Outlet (m³/h): 367
- Max. (m³/h): 329
- Min. (m³/h): 223
- Noise (LwA) Max Speed 69 dB
- Noise (LwA) Min Speed 62 dB
- Integrated halogen lamps
- 2 aluminium filters

Optional **Recirculation Kits** and **Filters** for installation without outlet available in page #137

COLOR

■ Stainless Steel

PRODUCT DIMENSIONS

Width 730mm



Ref. 40446753

TOTAL GFG 2



- Filter group
- Push buttons control panel
- Energy Efficiency class: D
- 3 speeds
- Exhaust capacities:
- Free Outlet, m³/h: 444
- Max., m³/h: 329
- Min., m³/h: 223
- Noise (LwA) Max Speed, dB: 63
- Noise (LwA) Min Speed, dB: 53
- 1 LED bar
- 1 stainless Steel filters MMX

Optional **Recirculation Kits** and **Filters** for installation without outlet available in page #137

COLOR

■ Stainless Steel

PRODUCT DIMENSIONS

Width 550mm

HOODS

HOOD ACCESSORIES

CONVENTIONAL CHARCOAL FILTERS

HOOD	TO BE CHANGED EVERY 3-6 MONTHS
COOKER HOOD DPL ISLA 1185	D4C Ref. 61801262
HOOD DH2 ISLA 985	
COOKER HOOD DG3 985	
DVI 88-G1 EOS BM	C1RTK Ref. 113290015
DLV 98660 BK	
DLV 98660 T05 WH	
DLV 98660 T05 ST	
DVT 98660 TBS BK	
DLV 68660 T05 BK	
COOKER HOOD ULTRASLIM NC 980/NC 680	
COOKER HOOD DLH 985 T	
COOKER HOOD DSH 985	
COOKER HOOD DSJ 980	
COOKER HOOD DBB 90 INOX (HP)	
COOKER HOOD DBB 90 / DBB 60	
COOKER HOOD CNL 9610 / CNL 6610 (2 Charcoal filters required)	D4C Ref. 61801262
GFL 57651 EOS BK (2 Charcoal filters required)	
GFL 77761 EOS IX (2 Charcoal filters required)	
COOKER HOOD TL 9310 / TL 6310 (2 Charcoal filters required)	CNL 1C Ref. 61801346
GFG 2 (2 Charcoal filters required)	
GFG 73 (2 Charcoal filters required)	
COOKER HOOD C 9310 / C 6310	C2R Ref. 61801239
COOKER HOOD CL 610 S	C4C Ref. 61801341
COOKER HOOD CL 610 W	

RECIRCULATION KITS (ONLY FOR RECIRCULATION HOODS)

HOOD WITH TUBE COVER	HOOD W/O TUBE COVER
1/T1 Ref. 40490149	
CG1 15200 L3C Ref. 113290032	CG1 15200 O2C Ref. 113290034
CFH 15200 L3C Ref. 113290018	CFH 15200 O2C Ref. 113290016
CFH 15200 L2C Ref. 113290017	
CFH 15200 L3C Ref. 113290018	
CFH 15200 L2C Ref. 113290017	



1/T1

HOODS



CG1 15200 O2C



CFH 15200 O2C



CFH 15200 L3C



CG1 15200 L3C



CFH 15200 L2C



CNL 1C



D4C



C4C



C2R



C1RTK

HOODS

HOOD ACCESSORIES

NEW REGENERATIVE FILTERS AND KITS:

In the constant effort that Teka does for the environment, we introduce the regenerative filters for hoods. With a self-cleaning system that avoids maintenance tasks and costs. You can change every 5 years and clean easily at home.



Comfort



Savings



Eco friendly

REGENERATIVE FILTERS

HOOD	REPLACE EVERY 3-5 YEARS
COOKER HOOD FIH 16760 TOS BK	R1RFB Ref. 113290014
DHT 97670 ROS WH	R1RES Ref. 113290026
DVI 88-G1 EOS BM	R1RTK Ref. 113290009
DLV 98660 BK	
DLV 98660 TOS WH	
DLV 98660 TOS ST	
DVT 98660 TBS BK	
DLV 68660 TOS BK	
COOKER HOOD ULTRASLIM NC 980/NC 680	
COOKER HOOD DLH 985 T	
COOKER HOOD DSH 985	
COOKER HOOD DSJ 980	
COOKER HOOD DBB 90 INOX (HP)	
COOKER HOOD DBB 90 / DBB 60	

RECIRCULATION KITS (ONLY FOR RECIRCULATION HOODS)

HOOD WITH TUBE COVER	HOOD W/O TUBE COVER
	RFH 36100 FOA Ref. 113290013
	RFC 60210 01B Ref. 113290025
RG1 15200 L3C Ref. 113290031	RG1 15200 O2C Ref. 113290033
RFH 15200 L3C Ref. 113290010	RFH 15200 O2C Ref. 113290012
RFH 15200 L2C Ref. 113290011	
RFH 15200 L3C Ref. 113290010	
RFH 15200 L2C Ref. 113290011	



R1RFB



R1RES

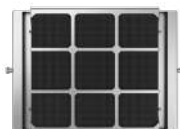

R1RTK



RG1 15200 L3C



RFH 15200 L3C



RFH 15200 L2C



RFH 36100 FOA



RFC 60210-01B



RG1 15200 O2C



RFH 15200 O2C



HOODS

TECHNICAL FEATURES

Model	FIH 16760 TOS BK	DHT 97670 ROS WH	DLV 98660	DVT 98660	DVI 88 Infinity G1	DLV 68660
PRODUCT FEATURES						
Annual energy consumption AEC kWh/annum (kWh)	37,4	34,4	43,1	38,7	40,1	42,4
Energy Efficiency Class	A+	A++	A+	A+	A+	A+
Fluid Dynamic Efficiency (FDEhood)	33,3	37,7	35	35,1	35,5	36,5
Fluid Dynamic Efficiency class	A	A	A	A	A	A
Light Efficiency (Lehood) lux/Watt	-	80	42	69,8	35,0	48
Lighting Efficiency class	-	A	A	A	A	A
Grease Filtering Efficiency (GFEhood) %	75,1	77	75,9	75,9	75,62	75,9
Grease Filtering Efficiency class	C	C	C	C	C	C
Air flow (Qmin) m ³ /h	415	317	290	307	232	232
Air flow (Qmax) m ³ /h	540	634	558	584	411	410
Air flow (Qboost) m ³ /h	600	808	696	698	726	725
Noise (LwA) Min Speed (dB)	62	50	51	61	47,4	49
Noise (LwA) Max Speed (dB)	67	67	67	72	60	65
Noise (LwA) Boost Speed (dB)	70	74	70	74	71,1	71
Off mode Power (Po) W	0,49	-	0,32	-	0	0,32
Standby Power (Ps) W	-	0,49	-	0,74	0,32	-
Energy Efficiency Index (EEI)	43,6	36,9	42,9	41	41,1	42,9
Time increase actor (f)	0,8	0,6	0,7	0,7	0,7	0,7
Air flow at best efficiency point (Qbep) m ³ / h	304	-	-	-	394	-
Air pressure at best efficiency point(Pbep) Pa	505	489	484	488	472	493
Electric power input at best efficiency point (Wbep) W	128	134,9	147	140	145,7	145
Nominal power of the lighting system (WL) W	-	6,6	7,5	4,2	4	7,5
PRODUCT DIMENSIONS						
Width (mm)	110	900	900	900	800	600
Depth (mm)	510	600	450	412	435	450
Height (mm)	186	214	800-1200	380	800-1100	800-1200
ELECTRICAL FEATURES						
Motor power (W)	145	220	265	280	270	265
Total hood power (W)	145	226,6	272,5	286	278	272,5
TECHNICAL DATA						
Anti Return Valve	-	-	√	√	√	√
Ø Outlet (mm)	-	215 x 85	150	150	150	150
Number of Filters	1	2	2		1	1
Charcoal filter	-	-	C1RTK	C1RTK	C1RTK	C1RTK
Recirculation kit	-	-	CFH 15200 L3C	CFH 15200 L2C	CG1 15200 L3C	CFH 15200 L3C

Model	DPL 1185 ISLAND	DH2 985 ISLAND	DG3 985 ISLAND	NC 980	NC 680
PRODUCT FEATURES					
Annual energy consumption AEC kWh/annum (kWh)	49,3	47,8	47,8	135,8	135,8
Energy Efficiency Class	A	A	A	D	D
Fluid Dynamic Efficiency (FDEhood)	32,1	32,3	32,3	12,7	12,7
Fluid Dynamic Efficiency class	A	A	A	E	E
Light Efficiency (Lehood) lux/Watt	58,3	58,3	58,3	65,2	73,8
Lighting Efficiency class	A	A	A	A	A
Grease Filtering Efficiency (GFEhood) %	75,9	83,4	83,4	83,7	83,7
Grease Filtering Efficiency class	C	C	C	C	C
Air flow (Qmin) m ³ /h	331	311	311	298	298
Air flow (Qmax) m ³ /h	629	605	605	402	402
Air flow (Qboost) m ³ /h	782	796	796	637	637
Noise (LwA) Min Speed (dB)	54	52	52	52	52
Noise (LwA) Max Speed (dB)	66	71	71	60	60
Noise (LwA) Boost Speed (dB)	69	71	71	70	70
Off mode Power (Po) W	-	-	-	-	-
Standby Power (Ps) W	0,74	0,6	0,6	0,56	0,56
Energy Efficiency Index (EEI)	50,1	50,1	50,1	90,2	90,2
Time increase actor (f)	0,8	0,8	0,8	1,5	1,5
Air flow at best efficiency point (Qbep) m ³ / h	346	341	341	427,0	427,0
Air pressure at best efficiency point(Pbep) Pa	464	456	456	257	257
Electric power input at best efficiency point (Wbep) W	139	133,7	133,7	240,0	240,0
Nominal power of the lighting system (WL) W	12	12	12	6	6
PRODUCT DIMENSIONS					
Width (mm)	1100	900	900	900	600
Depth (mm)	605	600	600	500	500
Height (mm)	817-1117	817 / 1117 + 62	871 - 1171	674-1004	674-1004
ELECTRICAL FEATURES					
Motor power (W)	280	280	280	230	230
Total hood power (W)	242	292	292	236	236
TECHNICAL DATA					
Anti Return Valve	-	√	√	√	√
Ø Outlet (mm)	150	150	150	150	150
Number of Filters	3	3	2	1	1
Charcoal filter	D4C	D4C	D4C	D4C	D4C
Recirculation kit	SET 1/T1	SET 1/T1	SET 1/T1	SET 1/N1	SET 1/N1

HOODS

TECHNICAL FEATURES

Model	PERFECTA4 DLH 985 T	DSH 985	DSJ 980	DBB 90 HP	DBB 90
PRODUCT FEATURES					
Annual energy consumption AEC kWh/annum (kWh)	41,0	54,7	96,7	185,9	62,3
Energy Efficiency Class	A	A	C	E	D
Fluid Dynamic Efficiency (FDEhood)	34,3	31	16,4	14,7	6,9
Fluid Dynamic Efficiency class	A	A	D	D	F
Light Efficiency (Lehood) lux/Watt	55,7	55,2	31,7	5,9	5,9
Lighting Efficiency class	A	A	A	F	F
Grease Filtering Efficiency (GFEhood) %	98,2	82	76,1	76,1	73,4
Grease Filtering Efficiency class	A	C	C	C	D
Air flow (Qmin) m3/h	352	305	268	295	234
Air flow (Qmax) m3/h	651	586	614	650	380
Air flow (Qboost) m3/h	760	735	-	-	-
Noise (LwA) Min Speed (dB)	54	54	48	48	44
Noise (LwA) Max Speed (dB)	72	72	-	-	-
Noise (LwA) Boost Speed (dB)	72	72	-	-	-
Off mode Power (Po) W	0,3	0,3	-	-	-
Standby Power (Ps) W	-	-	-	-	-
Energy Efficiency Index (EEI)	47,2	53,2	81,5	99,2	93,3
Time increase actor (f)	0,8	0,9	1,4	1,5	1,8
Air flow at best efficiency point (Qbep) m3 / h	364	388	363,1	473,9	210,6
Air pressure at best efficiency point(Pbep) Pa	417	440	301	260	99
Electric power input at best efficiency point (Wbep) W	123	153,1	185	232,9	83,7
Nominal power of the lighting system (WL) W	7	6	3	80	10
PRODUCT DIMENSIONS					
Width (mm)	900	900	900	900	900
Depth (mm)	480	480	480	480	480
Height (mm)	670-1000	670-1000	670-1000	749-1049	749-1049
ELECTRICAL FEATURES					
Motor power (W)	280	280	220	230	105
Total hood power (W)	287	286	223	310	115
TECHNICAL DATA					
Anti Return Valve	✓	✓	✓	✓	✓
Ø Outlet (mm)	150	150	150	150	150
Number of Filters	3	3	3	3	3
Charcoal filter	D4C	D4C	D1C	D4C	D4C
Recirculation kit	SET 1/NI	SET 1/NI	DICTP	SET 1/M1	SET 1/M1

Model	DBB 60	CNL 9610	CNL 6610	TL 9310	TL 6310
PRODUCT FEATURES					
Annual energy consumption AEC kWh/annum (kWh)	62,3	107,0	105,9	71,2	71,2
Energy Efficiency Class	E	C	C	D	D
Fluid Dynamic Efficiency (FDEhood)	6,9	17,2	17,2	10,9	10,9
Fluid Dynamic Efficiency class	F	D	D	E	E
Light Efficiency (Lehood) lux/Watt	5,9	33,3	42,7	4,6	4,9
Lighting Efficiency class	F	A	A	F	F
Grease Filtering Efficiency (GFEhood) %	73,4	72,8	72,8	69,3	69,3
Grease Filtering Efficiency class	D	D	D	D	D
Air flow (Qmin) m3/h	234	330	330	239	239
Air flow (Qmax) m3/h	380	445	445	339	339
Air flow (Qboost) m3/h	-	694	694	-	-
Noise (LwA) Min Speed (dB)	44	60	60	56	56
Noise (LwA) Max Speed (dB)	-	70	70	-	-
Noise (LwA) Boost Speed (dB)	-	70	70	-	-
Off mode Power (Po) W	-	-	-	-	-
Standby Power (Ps) W	-	-	-	-	-
Energy Efficiency Index (EEI)	93,3	82,7	82,4	88,1	88,1
Time increase actor (f)	1,8	1,4	1,4	1,6	1,6
Air flow at best efficiency point (Qbep) m3 / h	210,6	433	433	225	225
Air pressure at best efficiency point(Pbep) Pa	99	290	290	187	187
Electric power input at best efficiency point (Wbep) W	83,7	203	203	107	107
Nominal power of the lighting system (WL) W	10	5	3	12	12
PRODUCT DIMENSIONS					
Width (mm)	600	900	600	900	600
Depth (mm)	480	300/490	300/490	288/413	288/413
Height (mm)	749-1049	274	274	184	184
ELECTRICAL FEATURES					
Motor power (W)	105	230	230	130	130
Total hood power (W)	115	235	233	142	142
TECHNICAL DATA					
Anti Return Valve	√	√	√	√	√
Ø Outlet (mm)	150	150	150	120	120
Number of Filters	2	4	2	4	2
Charcoal filter	D4C	D4C	D4C	CNL 1C	CNL 1C
Recirculation kit	SET 1/M1	-	-	-	-

HOODS

TECHNICAL FEATURES

Model	C 6310	CL 610	GFL 7760 EOS IX	GFL 57651 EOS BK	GFH 73	GFG 2	DLV 68660
PRODUCT FEATURES							
Annual energy consumption AEC kWh/annum (kWh)	67,1	83,0	42,3	42,3	67,9	68,8	42,4
Energy Efficiency Class	D	D	A+	A+	D	D	A+
Fluid Dynamic Efficiency (FDEhood)	8,1	6,2	37,2	37,2	10,5	10,7	36,5
Fluid Dynamic Efficiency class	E	F	A	A	E	E	A
Light Efficiency (Lehood) lux/Watt	4,8	1,0	44,8	45	33,8	16,4	48
Lighting Efficiency class	F	G	A	A	A	C	A
Grease Filtering Efficiency (GFEhood) %	72,8	70,0	65	65	77,6	85,7	75,9
Grease Filtering Efficiency class	D	D	E	E	C	B	C
Air flow (Qmin) m ³ /h	115	147	245	245	296	240	232
Air flow (Qmax) m ³ /h	235	200	425	425	337	341	410
Air flow (Qboost) m ³ /h	-	-	760	760	-	-	725
Noise (LwA) Min Speed (dB)	45	52	54,4	54,4	62	53	49
Noise (LwA) Max Speed (dB)	-	61	68	68	-	-	65
Noise (LwA) Boost Speed (dB)	-	-	70,1	70,1	-	-	71
Off mode Power (Po) W	-	-	-	-	-	-	0,32
Standby Power (Ps) W	-	-	0,44	0,44	-	-	-
Energy Efficiency Index (EEI)	91,0	99,9	43,1	43,1	86,3	86,6	42,9
Time increase actor (f)	1,7	1,8	0,7	0,7	1,6	1,6	0,7
Air flow at best efficiency point (Qbep) m ³ / h	136	119	-	-	226,8	232,5	-
Air pressure at best efficiency point (Pbep) Pa	191	179	499	499	185	184	493
Electric power input at best efficiency point (Wbep) W	137	95,0	142,8	142,8	111,3	111,5	145
Nominal power of the lighting system (WL) W	12	3	8	8	4	5	7,5
PRODUCT DIMENSIONS							
Width (mm)	600	600	712	532	730	550	600
Depth (mm)	500	500	284	284	310	310	450
Height (mm)	150	149,5	282	282	175	178	800-1200
ELECTRICAL FEATURES							
Motor power (W)	105	110	270	270	130	130	265
Total hood power (W)	117	138	278	278	134	135	272,5
TECHNICAL DATA							
Anti Return Valve	√	√	√	√	√	√	√
Ø Outlet (mm)	120	120	150	150	120	120	150
Number of Filters	2	2	1	1	2	1	1
Charcoal filter	C2R	C4C	D4C	D4C	CNL 1C	CNL 1C	C1RTK
Recirculation kit	-	SET 1/N1	-	-	-	-	CFH 15200 L3C

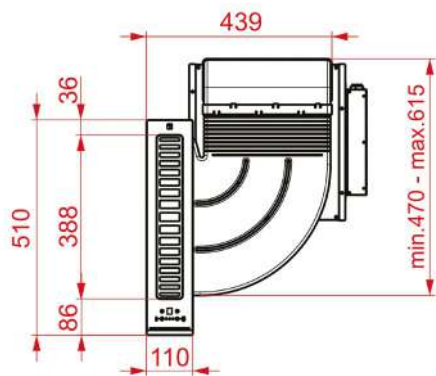

FIH 16760

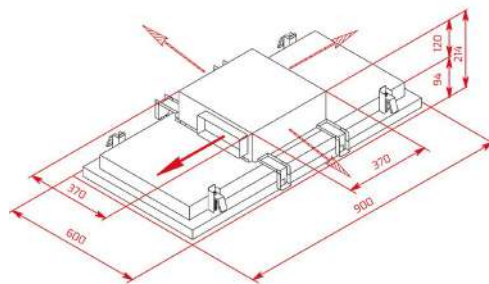

DHT 97670 ROS WH

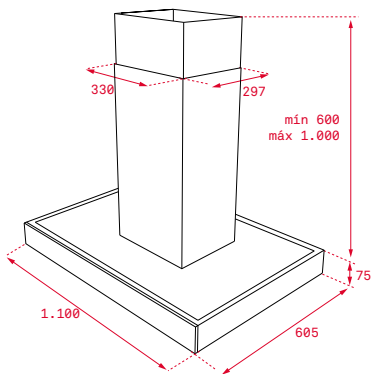

DPL 1185 ISLAND

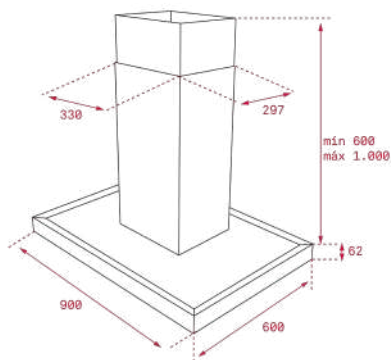

DH2 985 ISLAND

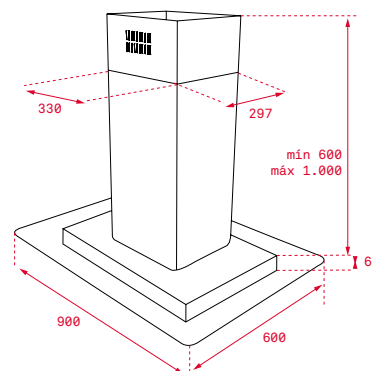

DG3 985 ISLAND

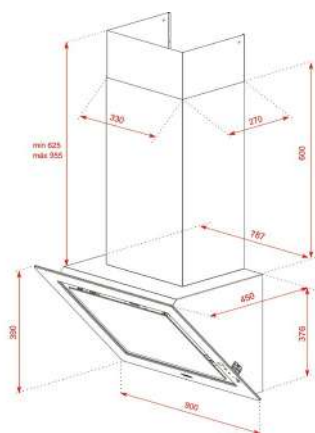

DLV 98660

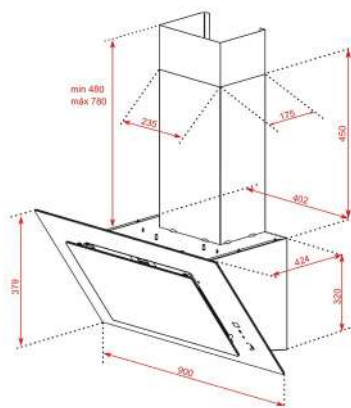

DVT 98660

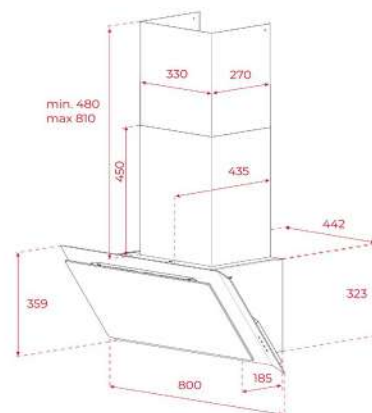

DVI 88 INFINITY G1

HOODS

INSTALLATION DIAGRAM

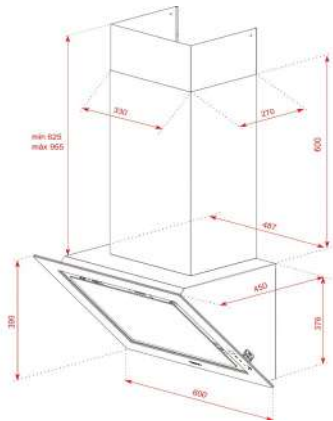

DLV 68660

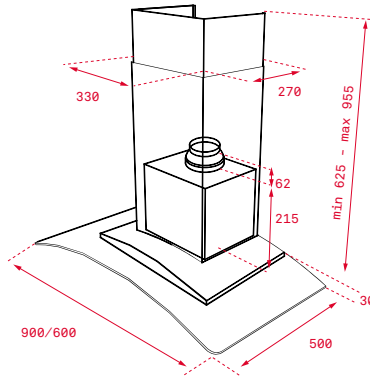

NC 980 / 680

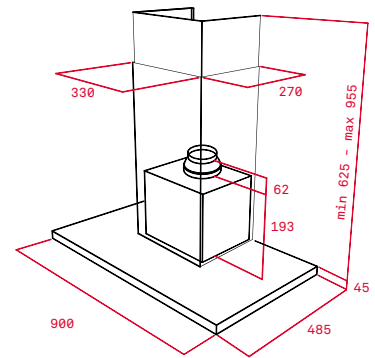

PERFECTA4 DLH 985 T

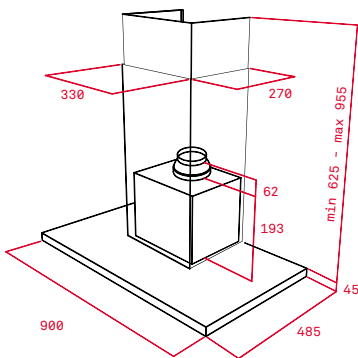

DSH 985

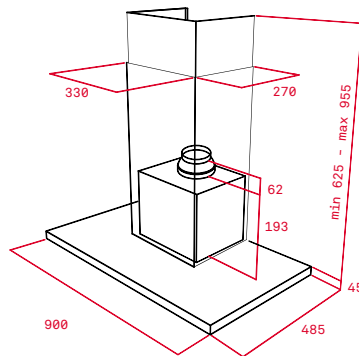

DSJ 980

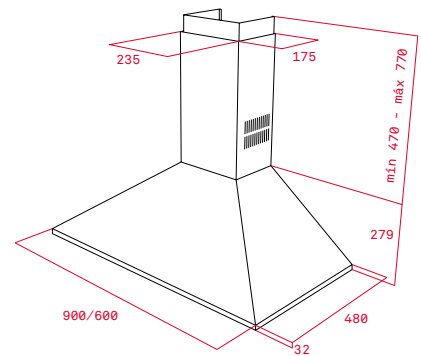

DBB 90 HP

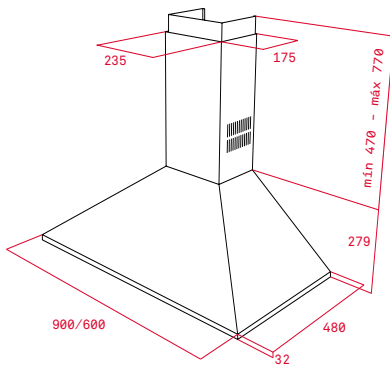

DBB 90/60

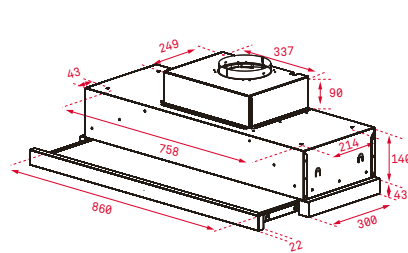

CNL 9610

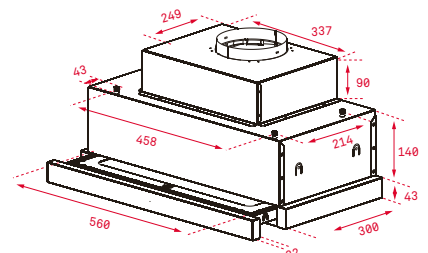

CNL 6610

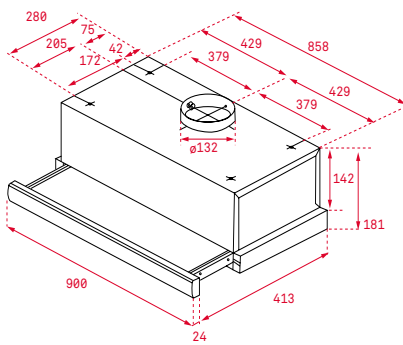

TL 9310

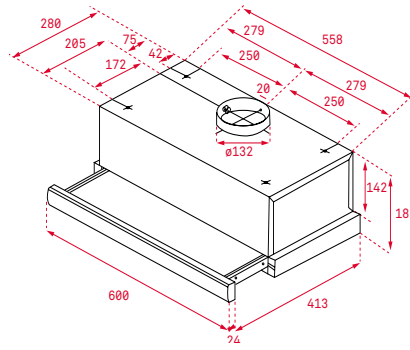

TL 6310

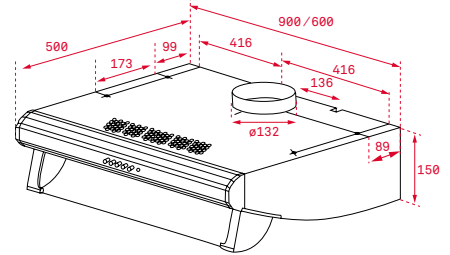

C 9310 / 6310

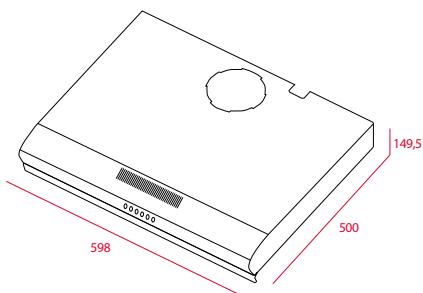

CL 610

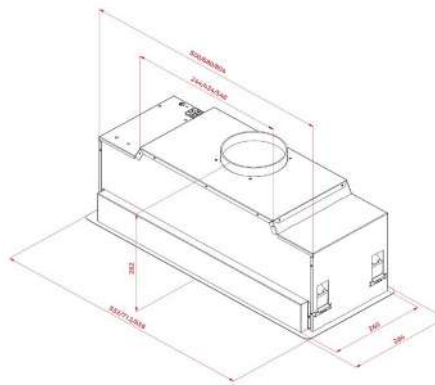

GFL 7760 EOS IX

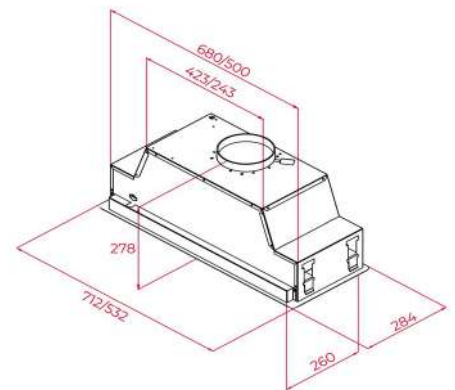

GFL 57651 EOS BK

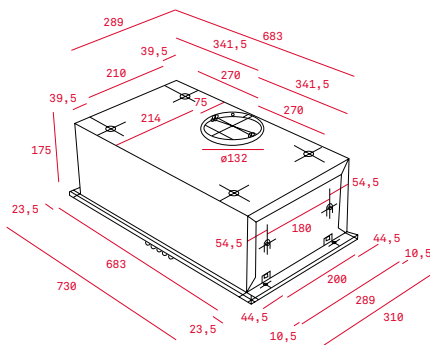

GFH 73

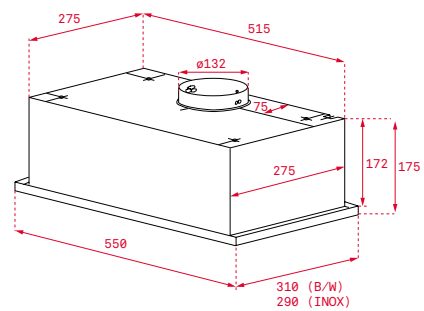

GFG 2

T

E

K

Cold Line

Meals and memories are kept inside



Freshness and convenience in complete harmony

IonClean technology

IonClean technology creates negative ions that neutralise bacteria and bad smell particles. Air inside the fridge will be superb this way and always fresh and free of odours.

TempGuard

Our TempGuard system controls and keeps the temperature thanks to sensors located inside. Any change is automatically fixed. Your fridge always at the real temperature your food needs.

MultiZone compartment: From freezer to fridge in just one touch

Room enough to keep food cold or even freeze it, thanks to the compartment with adjustable temperature: from cold to frozen. You can set the temperature you want to from -18°C to 7°C and have a complete control of your food and appliance. At your service.

LongLife No Frost

Keep your food perfect: goal achieved. LongLife No Frost technology keeps every compartment at the perfect moisture level thanks to the three independent cooling circuits. Your food remains fresh for longer.

FlexiRack

With the flexirack system, just pressing a side button, you can adjust the height of the door shelf anytime you need it.

FlexZone- flexible drawer

Precision is to keep food at perfect temperature. Your food remains fresh for longer at the perfect temperature. The latest technology of the Flexible Zone that helps you to adjust the temperature level depending on the kind of food or drinks you are storing. Welcome to wellness.

VitaCare Box

From farm to table VitaCareBox drawer has a personalised moisture control to keep your fruit and vegetables always fresh, preserving all their vitamins and nutrients for longer.

Bar on Door

Take drinks without opening the door with just one touch. Easy access to a special compartment for drinks avoiding opening the whole refrigerator. The BarOnDoor goes beyond an intelligent design, its simplicity at its best.

10 years Warranty Inverter Motor

Silence, durability and efficiency.

Feel the peace at home. Less consumption and more silence with the long-lasting inverter compressor. We take care of stillness and quietness at your home, while saving you money. Our refrigerators and freezers ranges are designed based on efficiency. Save more with the most advanced technology.



TEKA

- TEMPERATURE
- REF. TEMP.
- FR. TEMP.
- DEFROST
- ICE
- WATER
- POWER OFF

T.F.

3 CYCLE

COLD LINE

Cold line

Almost everything that matters happens in the kitchen.

MAESTRO

SIDE BY SIDE



RMF 75920 SS ME



RLF 74925



RFD 77825 GBK

2 DOOR BOTTOM FREEZER

BUILT-IN



CIB 350 NF



RSL 71735 FI ME



RSF 71725 FI ME



RVU 20046 GBK

MAESTRO

Domestic appliances for those who like going one step further. For those who will not settle for being like the rest.

TOTAL

Designed for those who demand everything of their appliances, for everyone in the house. Maximum effectiveness in any situation.

TOTAL



NFL 345 C



TKI4 215



TKI3 145 D ME



TFI3 130 D ME



TFI3 130 D ME



CI3 330 NF

COLD LINE



Ref. 113430030

MAESTRO RMF 75920 SS ME



- 4 doors refrigerator
- Full No Frost
- Electronic display with freezer and refrigerator temperature control and indicator
- LongLife No Frost with 3 independent circuits
- MultiZone compartment
- Eco function
- On holidays function
- Fast Freeze / Quick Cool function
- 2 FreshBox drawers
- LED illumination
- Safety lock for children
- Energy class: A+
- Climate class: N/T
- Total gross capacity : 620 litres
- Net capacity (fridge): 362 litres
- Net capacity (chiller): 38 litres
- Net capacity (freezer): 164 litres

COLOR

 Stainless Steel

PRODUCT DIMENSIONS

Height 1850mm **Width** 910mm **Depth** 750mm



Ref. 113430047

MAESTRO RFD 77825 GBK



- French Door with FlexZone drawers
- Motor inverter with high efficiency compressor
- IonClean technology
- Automatic Defrosting in refrigerator and freezer compartments
- Touch control with display
- Inner LED light
- Refrigerator compartment temperature display
- Freezer compartment temperature display
- Special drawers for multipurpose compartment
- 3 vegetable drawers
- 2 freezer drawers
- Fast freezing and cooling features
- Integrated handle
- Key lock indicator
- Total gross capacity: 600 litres
- Net capacity (fridge): 347 litres
- Net capacity (drawers): 169 litres

COLOR

 Black Glass

PRODUCT DIMENSIONS

Height 1898mm **Width** 833mm **Depth** 653mm



Ref. 113430020

MAESTRO RLF 74925



- Side by Side refrigerator
- Full No Frost
- Electronic display with freezer and refrigerator temperature control and indicator
- Bar on door system
- Eco function
- On holidays function
- Fast Freeze / Quick Cool function
- 2 FreshBox drawers
- 7 safety glass shelves with adjustable height
- LED illumination
- Safety lock for children
- 8 door balconies
- External metal handle
- Back wheels to move the appliance easily
- Adjustable feet (front/rear)
- Energy class: A++
- Climate class: N/T
- Total gross capacity : 574 litres
- Net capacity (fridge): 334 litres
- Net capacity (freezer): 156 litres

COLOR

 Stainless Steel

PRODUCT DIMENSIONS

Height 1788mm **Width** 895mm **Depth** 745mm



Ref. 113410003

TOTAL NFL 345 C



- Combi refrigerator
- Full No Frost
- Electronic control panel
- Display on door
- 4* freezer
- Safety glass shelves
- Fast Freeze / Quick Cool function
- LED illumination
- 3 inner shelves and 5 door balconies
- 3 Freezer drawers
- 1 ice tray
- 2 FreshBox drawers
- Reversible doors
- Energy class: A++
- Climate class: N/T
- Total gross capacity : 325 litres
- Net capacity (fridge): 219 litres
- Net capacity (freezer): 76 litres

COLOR

 Stainless Steel

PRODUCT DIMENSIONS

Height 1880mm **Width** 595mm **Depth** 635mm



Ref. 113500006

NEW

MAESTRO RSF 71725 FI ME



- Built-in Freezer
- Full No Frost
- Touch control Inner display
- 4* freezer
- Electronic adjustable thermostat
- Safety glass shelves
- Front and back adjustable feet
- Door on door installation
- Reversible doors
- Energy class: A+
- Climate class: SN/T
- Total gross capacity: 221 litres
- Net capacity: 197 litres

COLOR

White

PRODUCT DIMENSIONS

Height 1770mm **Width** 540mm **Depth** 545mm



Ref. 113460004

NEW

MAESTRO RSL 71735 FI ME



- Built-in Refrigerator
- Automatic defrost
- Inner control display
- Electronic adjustable thermostat
- (1)VitaCare Box drawers
- 5 safety glass shelves
- Fast cooling function
- Flexi rack
- Front and back adjustable feet
- Door on door installation
- Reversible doors
- Energy Class: A+
- Climate class: SN/T
- Total gross capacity: 303 litres
- Net capacity: 300 litres

COLOR

White

PRODUCT DIMENSIONS

Height 1770mm **Width** 540mm **Depth** 545mm



Ref. 40634573

MAESTRO C13 350 NF



- Built-in Combi
- No Frost
- Electronic control panel
- Fast Freeze / Quick Cool function
- Automatic defrost
- Antibacterial system
- Safety glass shelves
- Digital Temperature Indicator
- 1 ZeroBox drawer
- Chrome bottle rack
- Optical and acoustic temperature alarm
- Sliding door installation
- Reversible doors
- Energy Class: A++
- Climate Class: SN/ST
- Total gross capacity : 275 litres
- Net capacity (fridge) : 167 litres
- Net capacity (chiller) : 19 litres
- Net capacity (freezer) : 69 litres

COLOR

White

PRODUCT DIMENSIONS

Height 1776mm **Width** 540mm **Depth** 545mm



Ref. 40634574

TOTAL C13 330 NF



- Built-in combi
- No Frost
- Mechanical control panel
- 4* freezer
- Automatic defrost (refrigerator)
- Safety glass shelves
- Antibacterial gasket
- Sliding door installation
- LED illumination
- Reversible doors
- Energy Class : A+
- Climate Class : SN-T
- Total gross capacity : 275 litres
- Net capacity (fridge) : 193 litres
- Net capacity (freezer) : 69 litres

COLOR

White

PRODUCT DIMENSIONS

Height 1776mm **Width** 540mm **Depth** 545mm

COLD LINE



Ref. 40693157

TOTAL TKI4 215



- Built-in refrigerator
- Mechanical control panel
- 4 * freezer
- Safety glass shelves
- Sliding door installation
- 2 vegetable drawers
- Reversible door
- Energy Class : A++
- Climate Class : T
- Noise level : 39 dBA
- Total gross capacity : 210 litres
- Net capacity (fridge) : 156 litres
- Net capacity (freezer) : 19 litres

COLOR

White

PRODUCT DIMENSIONS

Height 1215mm **Width** 540mm **Depth** 545mm



Ref. 113500005

TOTAL TGI2 120 D ME



- Built-under freezer
- Electronic control panel
- 4* freezer
- 3 freezer drawers
- Door on door installation
- Reversible door
- Energy Class: A+
- Climate Class: SN-T
- Noise level: 39 dBA
- Total gross capacity: 96 litres
- Net capacity: 87 litres
- Voltage: 230 / 50 Hz

COLOR

White

PRODUCT DIMENSIONS

Height 820mm **Width** 598mm **Depth** 545mm



Ref. 113460002

TOTAL TF13 130 D ME



- Built-under refrigerator
- Inner control display
- 4* freezer
- Manual defrost
- Manual adjustable thermostat
- Door on door installation
- 2 safety glass shelves
- Front adjustable feet
- Reversible door
- Energy class: A++
- Climate class: SN/T
- Noise level:
- Total gross capacity: 125 litres
- Net capacity (fridge): 92 litres
- Net capacity (freezer): 15 litres

COLOR

White

PRODUCT DIMENSIONS

Height 818mm **Width** 595mm **Depth** 545mm



Ref. 113460003

TOTAL TK13 145 D ME



- Built-in fridge
- Mechanical control panel
- Manual defrost
- Safety glass shelves
- Door on door installation
- Reversible door
- Energy Class : A++
- Climate Class : SN-T
- Noise level : 40 dBA
- Total gross capacity : 130 litres
- Net capacity (fridge) : 128 litres
- Voltage : 230 / 50 Hz

COLOR

White

PRODUCT DIMENSIONS

Height 820mm **Width** 598mm **Depth** 545mm



Ref. 113600008

NEW

MAESTRO RVU 20046 GBK

- Built-in/Free standing Wine Cooler
- Capacity: 46 bottles
- 2 temperature zones:
- Adjustable temperature upper compartment: 5-10°
- Adjustable temperature lower compartment: 10-18°
- Inner control display
- Electronic adjustable thermostat
- Front and back adjustable feet
- LED Illumination
- Reversible doors
- Climate class: N/ST
- Total gross capacity: 150 litres
- Net capacity: 134 litres

COLOR

 **Black Glass**

PRODUCT DIMENSIONS

Height 820mm **Width** 595mm **Depth** 573mm



MODEL	RMF 75920 SS ME	RFD 77825 GBK UAE	RLF 74925	NFL 345 C	RSF 71725 FI ME	RSL 71735 FI ME
PRODUCT FEATURES						
Energy efficiency class (1)	A+	-	A++	A++	A+	A+
Annual consumption (KWh/year) (2)	481	306	322	224	297	144
Total Gross Capacity (litres)	620	600	574	325	221	303
Refrigerator compartment capacity (litres)	362	347	334	219	-	300
Chilling compartment capacity (litres)	38	-	NA	NA	-	-
Freezer compartment capacity (litres)	164	169	156	76	197	-
Freezer clasification (stars)	4	-	4	4	-	-
No frost in refrigeration compartment	✓	✓	✓	✓	-	-
No frost in chiller	✓	-	✓	-	-	-
No frost in freezer compartment	✓	✓	✓	✓	V	-
Temperature rise time (autonomy) (3)	13	N/A	14	15	9	-
Freezing Capacity (Kg/24h)	18	N/A	7	4	15	-
Climate class	N/T	SN/T	N/T	N/T	SN/T	SN/T
Noise level (dB)	45	35	43	40	41	40
Type of installation	Free Standing	Free Standing	Free Standing	Free Standing	Built-in	Built-in
ELECTRICAL FEATURES						
Power Rate (W)	328	250	188	150		
Defrost element power (W)	243	250	240	190	207	-
Energy consumption (Kw/day)	1,301	0,92	0,88	0,61	0,81	0,39

MODEL	CI3 350 NF	CI3 330 NF	TKI4 215	TGI2 120 D ME	TFI3 130 D ME	TKI3 145 D ME	RVU 20046 GBK
PRODUCT FEATURES							
Energy efficiency class (1)	A++	A+	A++	A+	A++	A++	-
Annual consumption (KWh/year) (2)	240	286	166	183	138	92	145
Total Gross Capacity (litres)	275	275	210	96	125	130	150
Refrigerator compartment capacity (litres)	167	193	156	NA	92	128	-
Chilling compartment capacity (litres)	19	NA	-	NA	-	NA	-
Freezer compartment capacity (litres)	69	69	19	87	15	NA	-
Freezer clasification (stars)	4	4	4	4	-	NA	-
No frost in refrigeration compartment	-	-	-	-	-	-	-
No frost in chiller	-	-	-	-	-	-	-
No frost in freezer compartment	✓	✓	-	-	-	-	-
Temperature rise time (autonomy) (3)	13	13	16	19	10	NA	-
Freezing Capacity (Kg/24h)	4	4	2	10	2	NA	-
Climate class	SN-T	SN-T	T	SN/T	SN/T	SN/T	N/ST
Noise level (dB)	40	40	39	39	37	40	39
Type of installation	Built-in	Built-in	Built-in	Built-in	Built-in	Built-in	Built-in / Free Standing
ELECTRICAL FEATURES							
Power Rate (W)	125	115	45	50	65	50	100
Defrost element power (W)	120	120	-	NA	-	NA	-
Energy consumption (Kw/day)	0,66	0,79	0,455	0,50	0,378	0,25	0,397

COLD LINE

INSTALLATION DIAGRAM

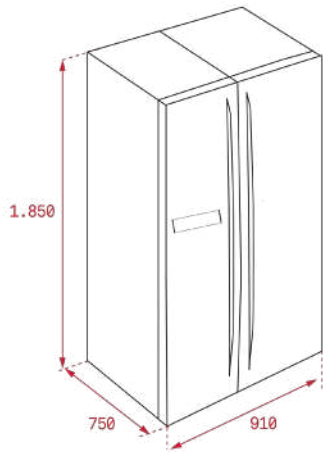

RMF 75920 SS ME

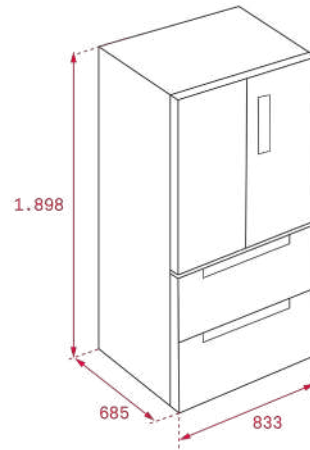

RFD 77820

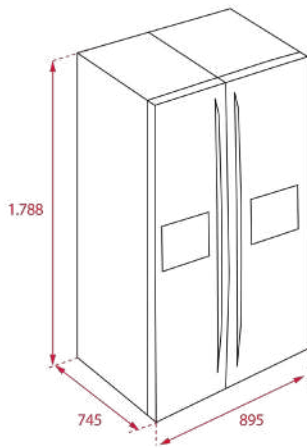

RLF 74925

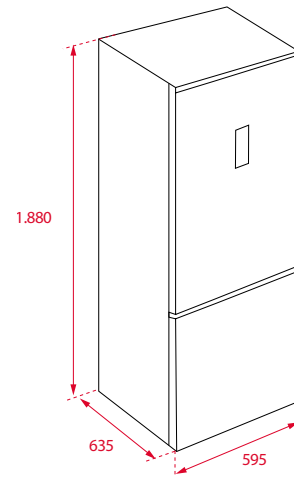

NFL 345 C

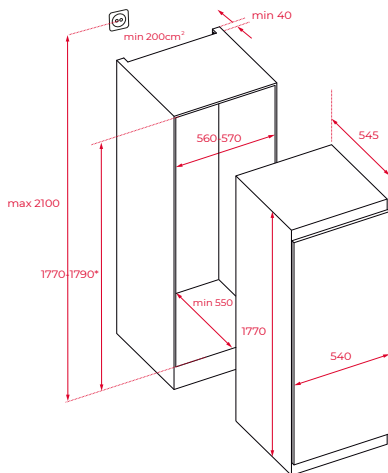

RSF 71725 FI ME / RSL 71735 FI M

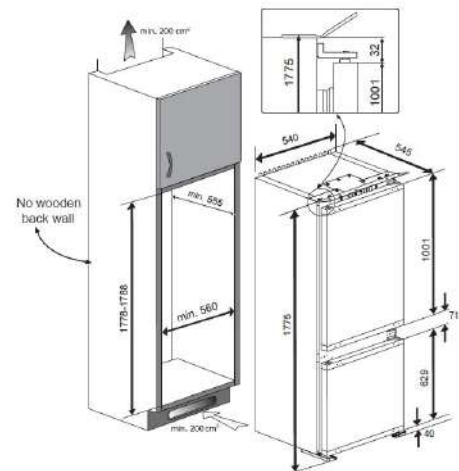

CI3 350 NF

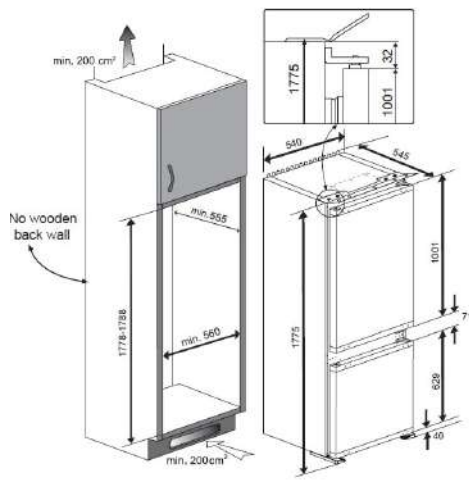

CI3 330 NF

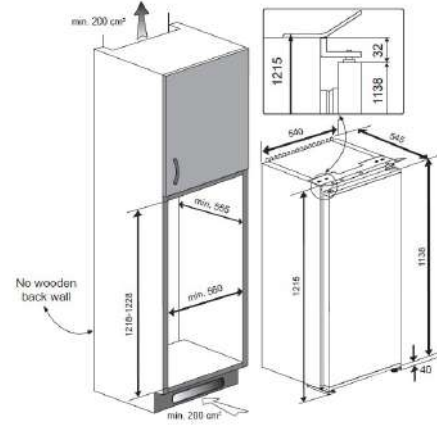

TKI4 215

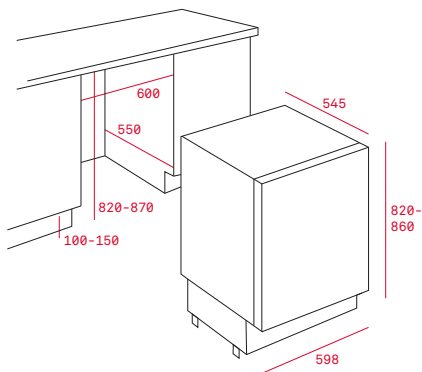

TG12 120 D ME

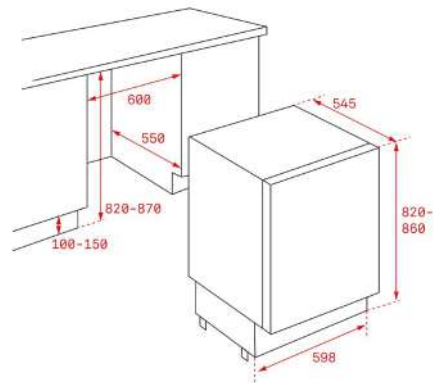

TF13 130 D ME

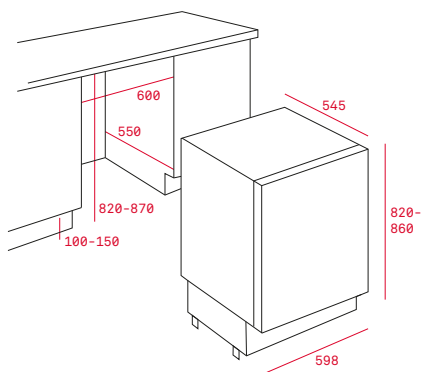

TKI3 145 D ME

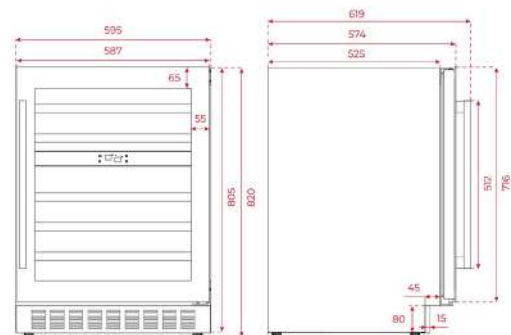

RVU 20046 GBK



Dishwashers

Caring for your loved ones
through pure hygiene

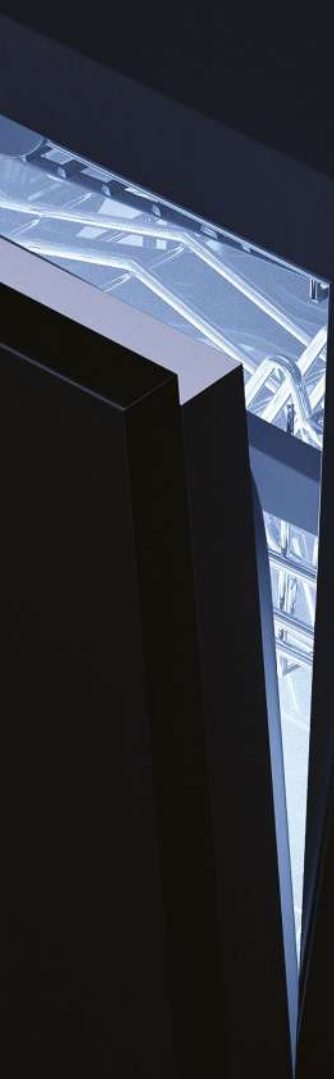

WORLDWIDE **NOVELTY**

New Dishwashers Series



SmartSensor

This innovative system identifies through sensors the dirtiness level of your kitchen wear and adjusts the washing parameters based on this. Optimal results in each cycle.



MultiCleaner

Use any kind of detergent you like, pots or powder, as your Dishwasher will adapt to either with the MultiCleaner system.



PremiumDry

A perfect finishing is achieved thanks to an excellent performance with minimum consumption. At the end of each cycle, the PremiumDry system will automatically open the Dishwasher door to complete the dishes drying process.



3rd Cutlery Tray

Your cutlery perfectly clean and with no food traces, thanks to our new wider and more flexible tray. Move and set its mobile parts to adjust to your needs in every cycle.



Beam on Floor

Our Dishwasher are so silent, that we have included a beam of light*, so that you can identify when it is working. When the light beam is off, means your Dishwasher is done with your dishes.

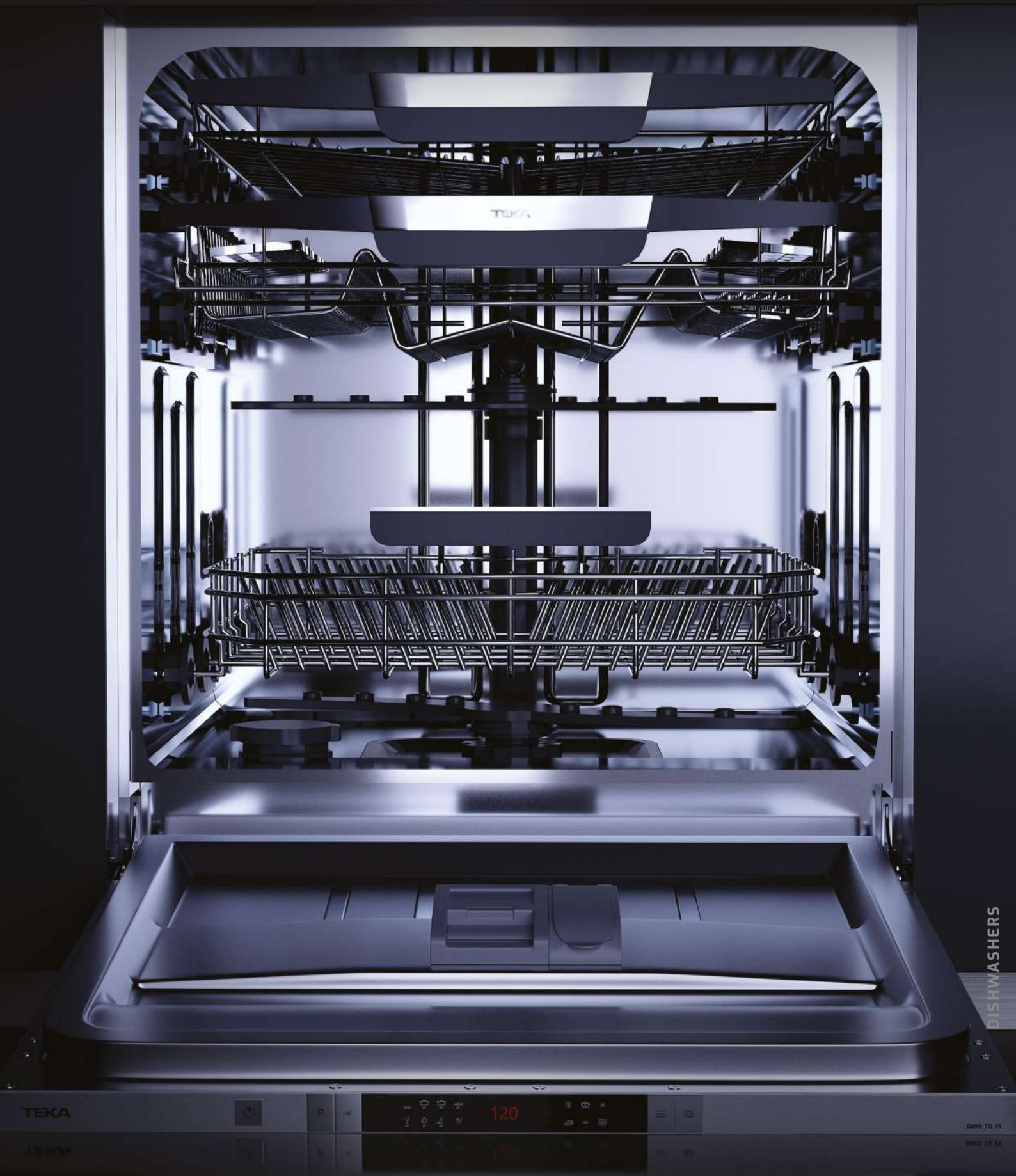

DISHWASHERS

TEKA



P



120



DW9 70 F1

DMS 13 52

Dishwashers

Experience the taste of life.

		MAESTRO	
		60	
INTEGRATED	15		
	14		
	13		DSI 46750 SS
FREESTANDING	14		DFS 76850 SS

MAESTRO

Domestic appliances for those who like going one step further. For those who will not settle for being like the rest.

TOTAL

Designed for those who demand everything of their appliances, for everyone in the house. Maximum effectiveness in any situation.

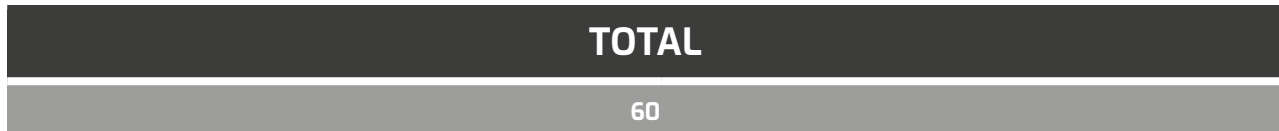

DFI 46950 ME



DFI 46700 ME

DISHWASHERS



Ref. 114270003

TOTAL DFI 46950 ME



- Fully integrated dishwasher
- Electronic control panel with white LED display
- Third cutlery tray
- Place Settings : 15
- Washing programs : 9
- Washing temperatures: 35°, 40°, 45°, 50°, 65°, 70° C
- Motor Inverter
- AquaStop safety system
- SmartSensor, measures the level of dirtiness
- MultiCleaner Sensor
- Beam on floor
- PushUp system with 3 positions
- FlexiSet4 lower basket
- Fast programs: 1Hour and Mini 30
- Special program: AutoClean
- GlassCare and DualCare
- Special functions: Half load,
- Express and Power Wash
- Extra Drying function
- Column installation
- SlidingDoor installation system
- Delay timer 1-24h
- Low salt and rinse indicator
- Energy efficiency class : A++
- Noise level: 46 dBA

COLOR

 **Stainless Steel**

PRODUCT DIMENSIONS

Height 818mm **Width** 598mm **Depth** 550mm



Ref. 114270010

TOTAL DFI 46700 ME



- Fully integrated dishwasher
- Electronic control panel with white LED display
- Place Settings : 14
- Washing programs : 7
- Washing temperatures : 35°, 40°, 50°, 65°, 70° C
- Motor Inverter
- AquaStop safety system
- SmartSensor measure the level of dirtiness
- MultiCleaner Sensor
- PushUp system with 3 positions
- FlexiSet4 lower basket
- Fast programs: 1Hour and Mini 30
- Special program: AutoClean
- Special functions: Half load
- Express and Power Wash
- Extra Drying function
- Column installation
- Delay timer 1-24h
- Low salt and rinse indicator
- Energy efficiency class : A+
- Noise level: 46 dBA

COLOR

 **Stainless Steel**

PRODUCT DIMENSIONS

Height 818mm **Width** 598mm **Depth** 550mm



Ref. 114270012

NEW

TOTAL DSI 46750 SS



- ExpertCare series
- Built-in dishwasher
- Electronic control panel with display
- Capacity: 13 plate settings
- Washing programs: 7
- Washing temperatures: 5
- SmartSensor measure the level of dirtiness
- FlexiSet FlexiSet2 lower basket
- AutoClean
- AutoProgram
- Intensive program
- ECO program
- 1-Hour program
- Whisper program
- Special functions:
- PreWash
- Half load
- Express
- ExtraDry
- AquaStop safety system
- Low salt and rinse indicator
- Adjustable upper basket
- Delay timer function: 1-24 hours
- Delay timer function: 1-24 hours
- Adjustable back feet from front
- Sliding detergent drawer
- Column installation

COLOR

■ Stainless Steel

PRODUCT DIMENSIONS

Height 815 **Width** 598mm **Depth** 570mm



Ref. 114260012

NEW

MAESTRO DFS 76850 SS



- PremiumCare series
- Free standing Dishwasher
- Electronic control panel with display
- Capacity: 14 plate settings
- Washing programs: 8
- Washing temperatures: 50°, 55°, 60°, 65°, 72°C
- Motor Inverter
- PremiumDry automatic opening system
- MultiFlex 3 cutlerly tray
- MultiCleaner Sensor
- FlexiSet 2 lower basket
- Special programs: AutoClean, AutoProgram, Intensive program, ECO program, 1-Hour, Whisper program, Hygienic, PreWash
- Special functions: Half load, Express, PowerWash, ExtraDry, AlternativeWash
- IonClean technology
- AquaStop and AquaSafe safety systems
- Low salt and rinse indicator
- Third sprayer
- Push-up adjustable upper basket
- Delay timer: 1-24 hours
- Noise level: 42 dBA
- Sliding Detergent drawer
- Column installation

COLOR

■ Stainless Steel

PRODUCT DIMENSIONS

Height 845mm **Width** 598mm **Depth** 600mm

DISHWASHERS

TECHNICAL FEATURES

Model	DFI 46950 ME	DFI 46700 ME	DSI 46750 SS	DFS 76850 SS
PRODUCT FEATURES				
Capacity (place settings)	15	14	13	14
Energy Efficiency Class (1)	A++	A++	A++	A+++
Energy consumption per year (kWh) (2)	270	266	262	218
Power consumption (kWh) (3)	0.94	0.93	0.92	0.76
Power consumption (Off and Left-On modes)	0.35/0.5	0.35/0.5	0.45/0.5	0.45/0.5
Water consumption year/litres (4)	2.660	2.660	3.080	2.744
Drying efficiency	A	A	A	A
Standard program	Eco 50	Eco 50	ECO	ECO
Cycle duration (minutes)	245	220	230	198
Noise (dB)	46	46	47	42
Installation	Built-in	Built-in	Partially Integrated	Free Standing
ELECTRICAL FEATURES				
Maximum Nominal Power (W)	2.100	2.100	2.100	2.100
SAFETY SYSTEM				
Aquastop	√	√	√	√
Aquasafe	√	√	√	√

DISHWASHERS

INSTALLATION DIAGRAM

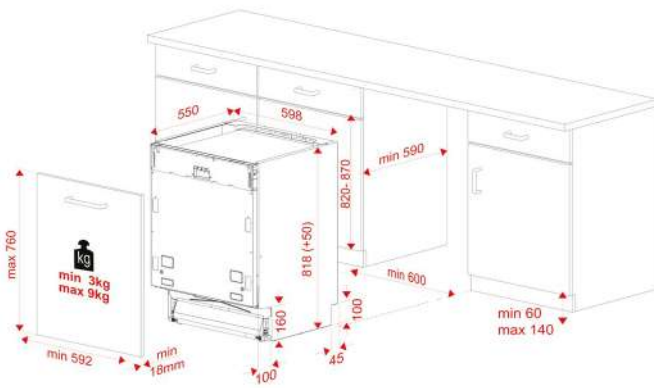

DFI 46950 ME

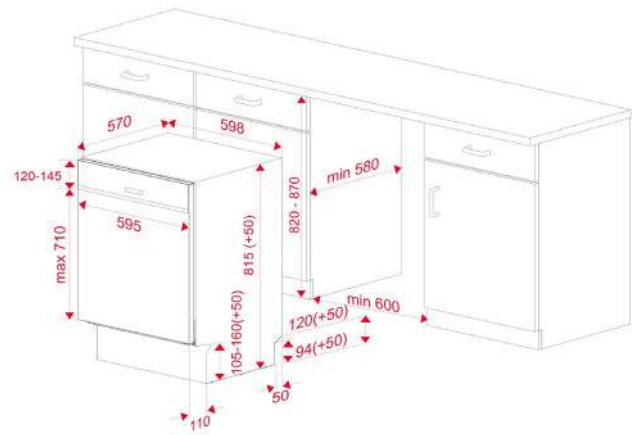

DSI 46750 SS

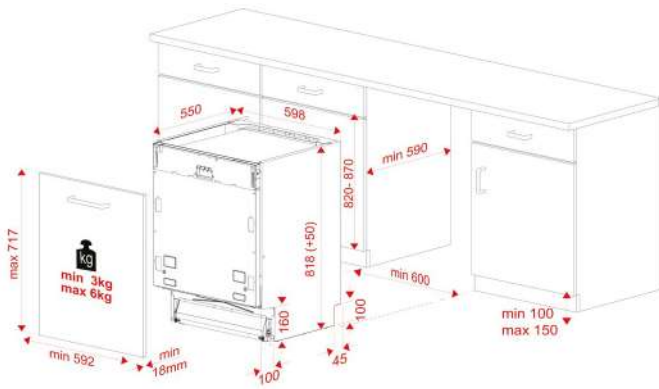

DFI 46700 ME

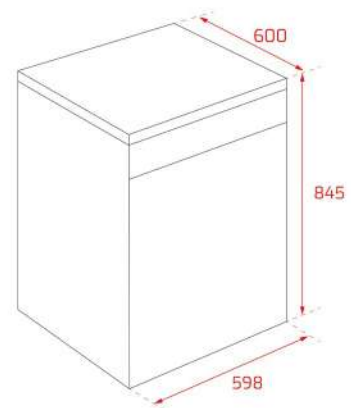

DFS 76850 SS



Laundry

The scent and softness of clean clothes reminds us of the best stages of life



Laundry day will become **your favourite day**

SmartWash

Ensure the minimum consumption with our smart system, which adjusts the washing parameters to the load.

SoftCare drum

The easiest way to break water resistance. The innovating Softcare design of the drum, made of dozens of small cubes, improves the gentle care of your laundry during washing, drying and spinning, even caring for your most delicate wool clothes.

ExcellentDry sensor

Delicate care for your clothes. Sensors control temperature and humidity to guarantee a perfectly dry result.

MyCycle

Choose your favourite program, type of clothes, temperatures, speed, and more. Your washing machine will memorize your parameters for whenever you need them, and you will know that it was designed just for you.

Steam function

An extra blow of hygiene. The steam eliminates germs, viruses and bacteria, and permits a fluffier laundry result with fewer wrinkles.



PREMIUMCARE Series

- OFF
- Algodón | Algodão
- ECO 40-60
- + PRELAVADO + pré-lavagem
- 20°C
- Colores coloridas
- Lana | Lã 30°C
- Alérgico
- Aclarado enxágue

DIGITAL DISPLAY

FUNCIONES | FUNÇÕES

2:40

TEMP.



CENTRIF.



DELAY START



VAPOR



SPEED WASH



INÍCIO PAUSA



(3s)



ALLERGY SAFE

T-INVERTER MOTOR



STEAM ASSIST

ECO3PLUS

TECHNOLOGY

LAUNDRY

Life is the sum of these moments that surprise us.

		MAESTRO		
		WASHER DRYER	WASHING MACHINE	
R.P.M.		8 KG / 6 KG	8 KG / 5 KG	8 KG
FREESTANDING	1600			
	1400	 <p>TK5 1480 WD SLIM WH</p>		
BUILT-IN	1400		 <p>L515 1481 EU</p>	 <p>L15 1481 EU</p>

MAESTRO

Domestic appliances for those who like going one step further. For those who will not settle for being like the rest.

TOTAL

Designed for those who demand everything of their appliances, for everyone in the house. Maximum effectiveness in any situation.

MAESTRO	TOTAL
DRYER	WASHING MACHINE
8 KG	7 KG



TK5 850 C



TK5 1470 S



TK5 1470 WH

LAUNDRY



Ref. 114030004

NEW

MAESTRO LS15 1481 EU



- Built-in Washer-Dryer
- Washing capacity: 8 kg
- Drying capacity: 5 kg
- Washing programs: 13
- Drying programs: 2
- Condenser dryer
- Electronic control panel
- Fast program: 14 minutes
- Special programs: ECO mode, Delicate
- Special functions: Delay timer, Stain type, Time dry
- Maximum spinning speed: 1400 RPM
- Automatic water regulation
- Automatic door lock safety system
- Child lock
- SoftCare drum
- Delay timer: 1-24 hours
- 35 cm wide porthole door
- Energy class: A

COLOR

White

PRODUCT DIMENSIONS

Height 820mm **Width** 596mm **Depth** 570mm



Ref. 114000009

NEW

MAESTRO LI5 1481 EUI



- Built-In Washing Machine
- Washing Capacity: 8kg
- 15 washing programs
- T Inverter Motor
- Electronic control panel
- Stainless Steel Drum
- Special Programs: Delicate Fabrics, Intensive and Resistant Fabrics Whool
- ECO Program
- Fast Program: 14 minutes
- Functions: Fast, Stain Level, Kg Detector
- Delay Timer: 1-24h
- Child Lock
- Maximum spin speed: 1400 RPM
- Max. Nominal Power: 1600 (W)
- Energy class: A+++

COLOR

White

PRODUCT DIMENSIONS

Height 820mm **Width** 596mm **Depth** 570mm



Ref. 113960009

NEW

MAESTRO TK5 1480 WD SLIM WH



- Free standing washer-dryer
- Washing capacity: 8 Kg
- Spinning capacity: 8 Kg
- Dryer capacity: 6 Kg
- Washing programs: 16
- Programs: My Cycle, Sport Wear, Jeans, 20°C, Intensive,
- ECO 40-60, Wool, Spin Only, Dry Only, 1 Hour W/D, Mix,
- Rinse & Spin, Quick 15', Wash adn Dry, Cotton.
- Electronic control panel
- Digital display
- Start Delay program 0-24 h
- Drum Capacity: 52,7 Litres
- Spinning speeds: 1400-1200-800-600-400-0
- Temperature selection: Cold-20°C-30°C-40°C-60°C-90°C
- Energy class: B

COLOR

White

PRODUCT DIMENSIONS

Height 850mm **Width** 595mm **Depth** 475mm



Ref. 113910009

NEW

TOTAL TK5 1470 S



- Free standing Washing Machine
- Washing capacity: 7 Kg
- Washing Programs: 16
- Special Programs economy, Delicates
- Electronic control panel
- Stainless Steel Drum, 45,5 Liters
- Spinning speeds: 0-400-600-800-1000-1200-1400
- Indicator pilots for: Temperature and speed
- Time left, Selected Programme, On/Off.
- Start Delay program 1-24 hours
- Fast Program 15 minutes
- Energy class: A+++

COLOR

Silver

PRODUCT DIMENSIONS

Height 850mm **Width** 595mm **Depth** 495mm



Ref. 113910006

NEW

TOTAL TK5 1470 WH



- Free standing Washing Machine
- Washing capacity: 7 Kg
- Washing Programs: 16
- Special Programs economy, Delicates
- Electronic control panel
- Stainless Steel Drum, 45,5 Liters
- Spinning speeds: 0-400-600-800-1000-1200-1400
- Indicator pilots for: Temperature and speed
- Time left, Selected Programme, On/Off.
- Start Delay program 1-24 hours
- Fast Program 15 minutes
- Energy class: A+++

COLOR

White

PRODUCT DIMENSIONS

Height 850mm **Width** 595mm **Depth** 495mm



Ref. 40854101

MAESTRO TKS 850 C



- Free standing dryer
- Condenser dryer
- 16 programs
- Drying capacity: 8 Kg
- Electronic control panel with display
- Delay timer 1-24h
- 4 Power levels
- End of cycle alarm
- Speed dry function
- Humidity sensor
- Anti-crease program
- Delicate clothing program
- Cooling program
- Bi- direction rotation
- Remaining time indicator
- Removable filter with saturation level indicator
- LED indicators for: on/off, filter saturation and full tank
- Energy class: B

COLOR

White

PRODUCT DIMENSIONS

Height 845mm **Width** 595mm **Depth** 615mm

Model	LSI5 1481 EU	TK5 1480 WD SLIM WH
-------	--------------	---------------------

PRODUCT FEATURES

Energy efficiency class	A	B
Energy consumption for washing, spinning and drying, kWh	5.44	
Washing performance class	A	B
Maximum spinning speed	1400	1400
Washing capacity	8	8
Drying capacity	5	6
Cycle duration (minutes)	570	-
Energy consumption per year	220	-
Condensation efficiency	-	-
Energy cycle consumption full/partial load (kWh)	-	-
Water consumption (litres/year)	11000	-
Noise level washing/spinning (Db)	48/75	58/76
Noise level dB washing/spinning	56/78/62	56/72/58

POWER SUPPLY

Voltage (V)	220-240	220-240
Maximum Nominal Power (W)	2.000	2.200
Nominal Power motor (W)	500	340
Nominal Power heating element (W)	1.200	2.000

Model	LI5 1481 EUI	TK5 1470
-------	--------------	----------

PRODUCT FEATURES

Filter - Washing capacity (Kgs)	8	7
Energy efficiency class	A+++	A+++
Energy consumption (kWh/year)	118	174
Consumption cycle energy (kWh)	0.54/0.49/0.49	0.91/0.69/0.61
Consumption On/Off and left on modes (kWh)	0.95	0.5/1
Water consumption (litres/year)	9850	9900
Spinning efficiency	A	B
Filter - Maximum spinning speed (RPM)	1400	1400
Percentage of water after the spinning (%)	53	53
Cycle duration (minutes)	330/285/285	240/230/230
Noise level washing/spinning (Db)	48/75	62/79

BUILT IN DOOR MEASUREMENTS

Door height (mm)	-	-
Door width (mm)	-	-

POWER SUPPLY

Voltage (V)	220-240	220-240
Maximum Nominal Power (W)	1600	2050
Nominal Power motor (W)	350	-
Nominal Power heating element (W)	1600	-

Model	TK5 850 C
-------	-----------

PRODUCT FEATURES

Drying capacity (Kgs)	8
Drying technology	Condenser
Energy Efficiency Class (1)	B
Energy consumption per year (kWh) (2)	561
Humidity sensor	✓
Energy consumption per drying cycle (Full/Half load) (kWh)	4.74/2.56
Power consumption in off-mode and left-on mode	0.28/0.80
Program duration Tt, T1, T 1/2 (minutes) (3)	112/140/90
Condensation efficiency (4)	B
Condensation percentages C1, C 1/2, Ct (5)	80,1/80,1/80,1
Noise level dB washing/spinning	69

POWER SUPPLY

Voltage (V)	220-240
Nominal Power heating element (W)	2.500

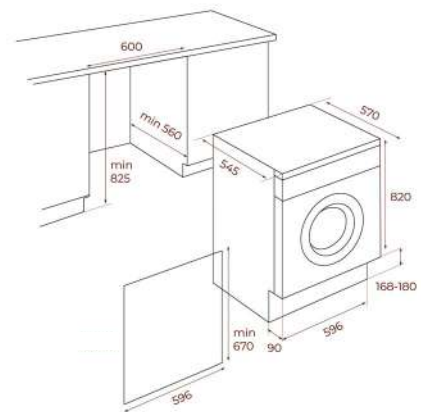

LSI5 1481 EU

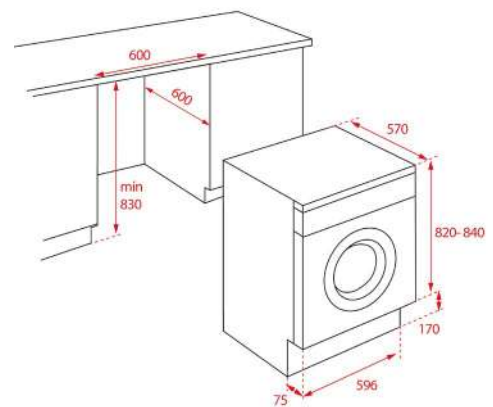

LI5 1481 EUI

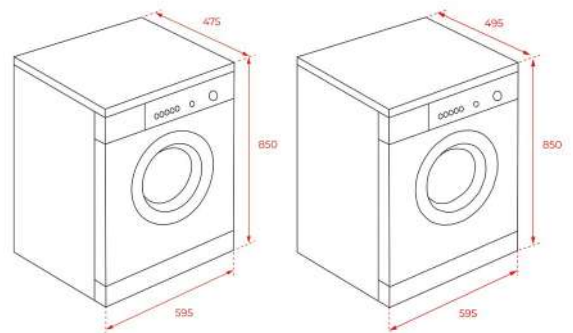

TK5 1480 WD SLIM WH



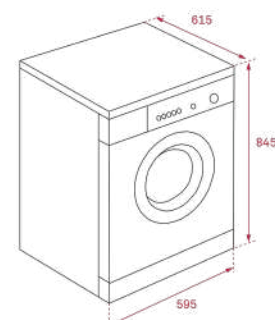















TK5 1470











TK5 850 C

KEY TO ICONS



OVENS

	Fingerprint Proof
	MeatProbe
	44L Capacity
	64L Capacity
	69L Capacity
	70L Capacity
	72L Capacity
	76L Capacity
	77L Capacity
	DualClean Cleaning system
	Full Extension Telescopic Guide
	HydroClean
	The SteamBox Included
	Plus Extension Telescopic Guide
	Pyrolysis Cleaning System
	SoftClose
	SurroundTemp
	A Energy Class
	A+ Energy Class





MICROWAVES







	20L Capacity
	22L Capacity
	40L Capacity
	44L Capacity
	Ceramic base
	Defrost By Time
	Defrost By Weight
	Direct Access Menu
	Electronic Door Opening

COFFEE MACHINE









	Ground coffee
	Capsules
	Coffee beans

HOBBS

	Auto ignition
	Autolock
	Easy Installation
	ExactFlame









	Flex
	MultiSlider
	Power
	Power Plus
	Slider
	Syncro function

HOODS

	LED light bar
	FreshAIR
	PERFECTA-4
	RIM Extraction
	Remote Control
	Stop Delay Timer
	A Energy Class
	A+ Energy Class







DISHWASHERS

	Eco Function
	Half Load
	Third Cutlery Tray









-  **Third Sprayer**
-  **A++ Energy Class**
-  **A+++ Energy Class**
-  **Multiflex**
-  **Beam On Floor**
-  **Extra Dry function**
-  **Smart Sensor**
-  **Multi Cleaner**
-  **Sliding Door**

COLD LINE











-  **Eco Function**
-  **Bar On Door**
-  **Fresh Box**
-  **Full No Frost**
-  **Gourmet Box**
-  **IonClean Technology**
-  **LED**
-  **LongLife No Frost**

-  **Motor inverter**
-  **On Holidays function**
-  **Vitacare Box**
-  **Zero Box**
-  **A Energy Class**
-  **A+ Energy Class**
-  **A++ Energy Class**

LAUNDRY

-  **Fingerprint Proof**
-  **Hand Wash**
-  **Washing capacity: 10Kg**
-  **Washing capacity: 7Kg**
-  **Washing capacity: 8Kg**
-  **Woolmark Certificate**
-  **A Energy Class**
-  **A+ Energy Class**
-  **A+++ Energy Class**

TAPS

-  **Anti-Scale Aerator**
-  **Swivel Spout**
-  **High Resistance**
-  **Easy Installation**
-  **Pull Down Shower**
-  **Resistance**
-  **PVD Coated**
-  **Fingerprint-Proof**
-  **AISI 304**
-  **Water Saving**
-  **Eco**



Sinks & Taps

Middle East Catalogue



SINKS & TAPS

SINKS	02
TAPS	66
WASTE DISPOSER	80
SINK ACCESSORIES	83
WASTES AND CONNECTION KITS	84





SINKS

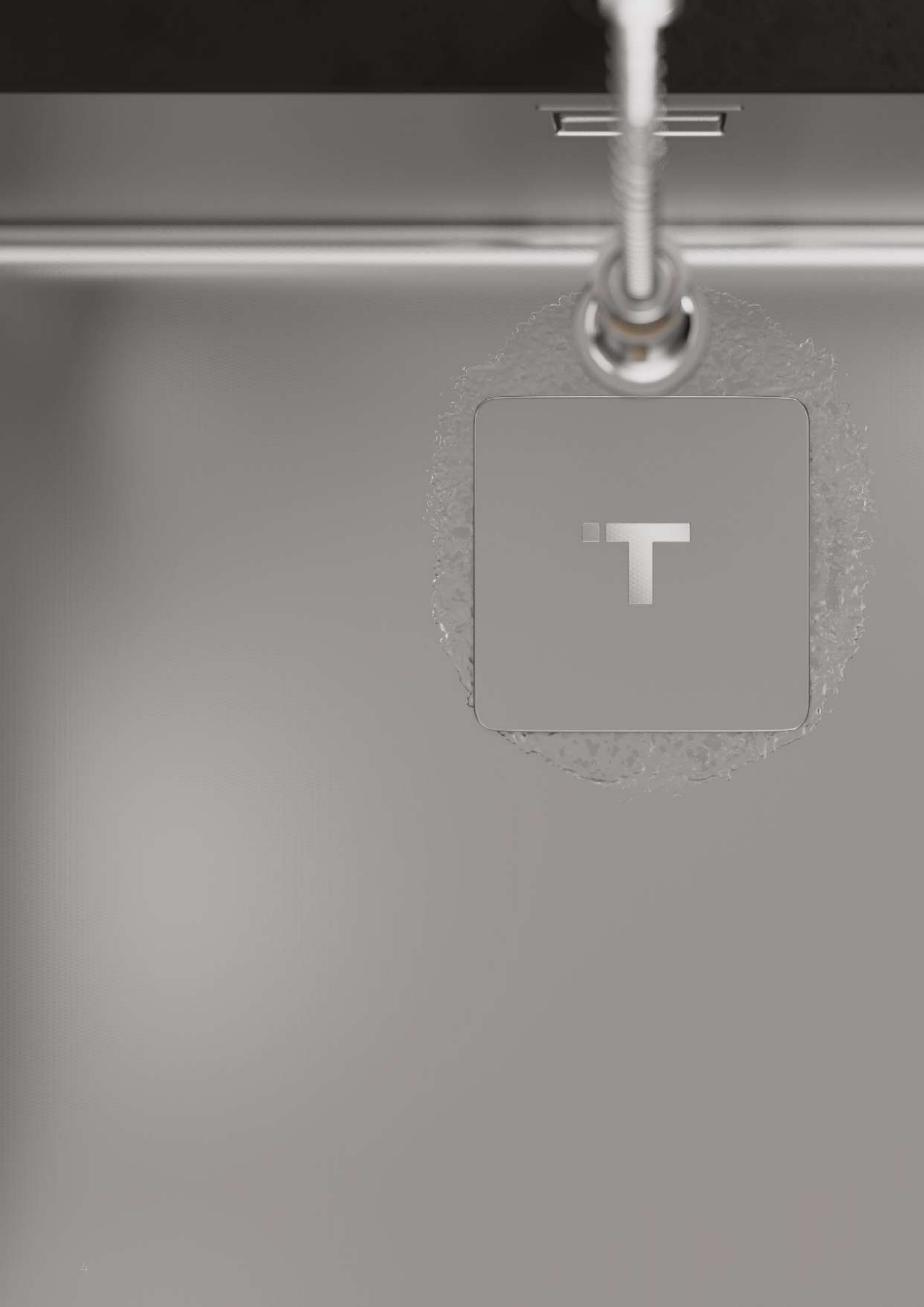

More than just a sink

Lifetime Warranty

More than 90 years of experience in the manufacturing of sinks allows us to offer the best guarantee

Teka sinks are defined by their top quality, durability, extremely resistant austenitic stainless steel, ergonomic design, functionality, hassle free installation and excellent service. They are made in Europe and all our factories have the highest quality certifications and are environment friendly.

Sinks with unlimited lifetime warranty

At Teka, we are so confident in our quality standards that we offer an unlimited lifetime warranty on all of our stainless steel kitchen sink models for you to be completely at ease. Visit teka.com for more information.



* Warranty only applicable for residential products. Fitting excluded. All product exchanges and returns require Teka's express approval. Tap and accessories excluded.

SilentSmart, the invisible protagonist

50% less noise: maximum comfort and well-being

Is the kitchen sink one of the source of irritating noise that affects your family? R515 Series are the best in their class. They feature a design and low-noise component to make them extremely quiet. The sound-dampening pads are their best partner. They, together with their special distribution, can reduce noise when water falls during operation, ensuring your comfort and convenience all day.





PureClean, Extra hygiene and cleanliness with the new waterproof treatment

Our new PureClean treatment gives you a clean and dry surface, preventing the build up of bacteria in your sink. In addition to the antiseptic benefit of stainless steel, with this coating, lime, dirt, and all the particles that previously remained in the sink can be drawn away, giving you a cleaner and more hygienic product.



Anti-fingerprint, an impeccable result.

With the premium SofTexture finish that provides an anti-fingerprint surface, with a matte look that fits perfectly with the latest trends in kitchen design.



Design, a touch of sophistication through a cleaner and modern design.

Its R515 radius makes it easy to clean and drain the water. The decorative elements elegantly cover the base of the sink. Greater capacity with a depth of 20cm.





FlexLinea, a series with multiple possibilities

*FlexLinea sinks offer
distinction and versatility at all
levels.*

FlexLinea, a series of sinks that satisfies all tastes

Flexibility is one of the main priorities for Teka, that's why this series has been developed.

It offers a wide variety of different sink compositions in different sizes, all of them with overflow and squared waste, to offer a look according to current trends, along with the easy-cleaning radius 15.

A sink you can install in all kind of countertops thanks to its triple mount installation option: undermount, top mount or flush mount.

All the series comes with lifetime warranty and SilentSmart system which reduces water dripping sound by 50% .

They are the best of their kind, the integrated manufacturing process stands for environmentally friendly and efficient production.

Enjoy the peacefulness offered by the lifetime warranty and the new SilentSmart system.



Undermount



Top mount



Flush mount



**LIFETIME
WARRANTY**
Valid for all stainless steel sinks. See conditions at teka.com



**SILENTSMART
TECHNOLOGY**

Zenit Series, multifunction workstation

Zenit Series are distinguished by their versatility, and, above all, because they bring order in your kitchen.

More than just a sink

Zenit is not simply another series of sinks. It is a food preparation area with ergonomic accessories perfect to cut, wash, cook, serve, and... enjoy! Its new square-shaped SQ valve combines with the attractive straight lines that bring personality and design to your kitchen, with a professional look and the peace of mind offered by the lifetime guarantee and the new SilentSmart system.



Zenit Cooking Set

Teka has developed an exclusive cooking set that includes:

- 3 ceramic dishes of different sizes suitable for ovens, microwaves and dishwashers.
- Bamboo chopping board.
- Set of silicone lids that allow you to preserve food.
- The square-designed inox soap dispenser, An inox colander that stands on the bowl rim.
- A popup waste match perfectly with Teka sinks.



Tegranite+, high quality

Teka Tegrinite+ sinks have evolved into a work area for kitchen lovers that look for innovation, practicality and functionality in the kitchen.

Stone, Forsquare and **Square** are the series for our new Tegrinite+ products. They were made with high quality Quartz, a material on the rise. 80% Quartz combined with acrylic resins to obtain a hardened material very resistant to thermal shocks, impacts and dirt. In addition, it is available in a wide range of colors. Quality and color... you can choose!

- **Scratch-proof surface:** high resistance surface to high temperatures and violent shocks.
- **Color intensity:** Excellent UV resistance and long color durability. Its specific method in coloring granite-particles provides higher resistance against decoloring.
- **Hygiene:** The material is non-porous, its surface is very easy to clean and leaves no place for bacteria.
- **Food safe:** Additionally, Tegrinite+ have an anti-bacterial protection enriched by silver ions which reject bacterial microorganisms.
- **Easy to clean:** Tegrinite+ features an odorless and stain-resistant finish. Cleaning up couldn't be any easier or faster!
- **High-resistant packaging** to minimize breakage. The sink is suspended and fully protected inside a twin double-box, creating a safety perimeter to avoid impacts.

Teka only endorses sinks made of innovative materials, that have great durability and are easy to clean.





Metallic Black



Black Carbon

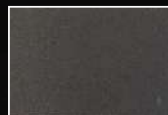

Dark Grey



White



Sandbeige



Metallic Grey

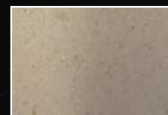

Topasbeige

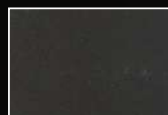

Black



Stone Grey

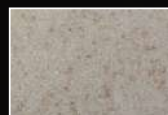

Avena Beige

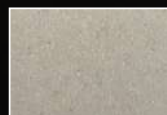

Bright Cream



White

Universe, unique personality

The new Universe series was born with details in mind, offering the best solution with a unique and avant-garde design. It stands out for its variety, functionality and the beauty of its surface.

Wide variety of solutions for your kitchen:

the new Universe series offers a range of compositions, sizes and finishes to choose the sink that best suits your lifestyle.

Greater capacity for utensils with buckets up to 195 mm deep.



**LIFETIME
WARRANTY**

Valid for all stainless steel sinks. See conditions at teka.com



Stainless Steel finishes, a long time durability

As experts in the work of stainless steel, you can choose your sink between these finishes.

Polished: an elegant finish that can be found in a large number of Teka sinks. The steel is subjected to various processes of both manual and mechanical polishing, obtaining a product with a lasting shine and easy cleaning. A sink that is impervious to water stains and calcium deposits.



Natural: deep drawing process produces an uniform pattern of satin finish lines on the surface and a natural transition: from the initial brightness of sink's top to the matt finish of the bowl where stainless steel has been stretched to its limits.



Micro-textured: those with a rough surface in high relief on the surface of the sink that combines perfectly with the aluminized finishes of the kitchen.

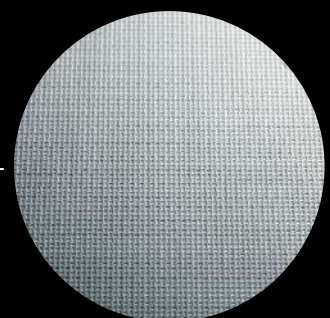

Packaging and Basket Wastes



Individual carton box

Teka sinks presented in individual carton boxes are stamped with the Teka logo and a sticker showing the name of the product and the code number. Inside the box, the sink and the accessories such as basket waste, connections, siphon, fixing clips and sealing strips for its installation are included.



Cardboard protection

It is a comfortable and secure way of packing the sinks for its sale in big stores. Although the sink is not inside a carton box, the protection around the sink perimeter is good enough and it contains the fixing clips and sealing strips. The kit that includes basket wastes, connections and siphon should be ordered apart and are provided separately without extra cost.

Basket wastes with overflow, connections and siphon are provided for all teka sinks



Teka provides the necessary wastes, connections and siphon for your sink



Extra accessories and fittings are available under request

Included inside the box, in case of the carton box sinks.
To be ordered apart in case of the sinks packed with cardboard protection (without extra cost).

Teka sinks, maximum installation flexibility

When choosing a sink, it is necessary to consider the style of kitchen, and what can be more functionally comfortable.

Undermount

A popular option to install with stone, granite and modern composite materials. This sink is mounted and caulked from underneath using the special clips provided. Undermounting is very easy to clean, and prevents dirt from getting stuck around or below the rim, the countertop is completely smooth and the sink looks elegant and practical. The sink is absolutely waterproof!

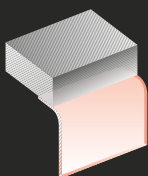

Top mount

A slimmer rim grants for an accurate positioning of the sink on your countertop. It is suitable for countertops of any material, and it is recommended especially for wood or laminates. Its small rim prevents water spilling onto the countertop.

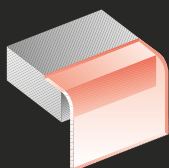

Flush mount

Sink and countertop become one solid unit, free of awkward edges and corners. The rim of the bowl is milled into the countertop, the cut-out must be very accurate. The totally seamless working area is also aesthetically pleasing and easy-to-clean. Ideal for natural materials like stone where milling is not a problem.

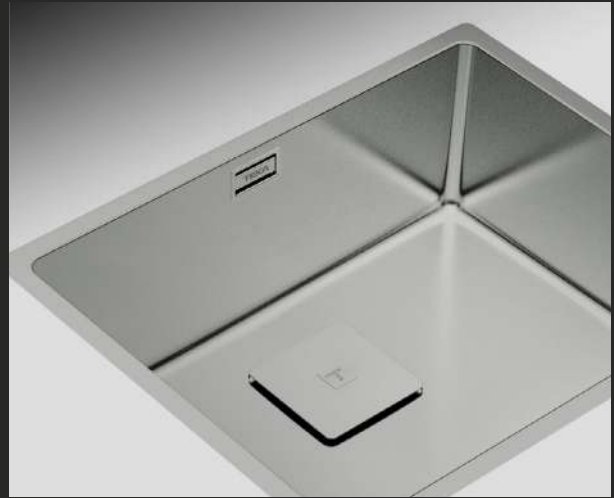
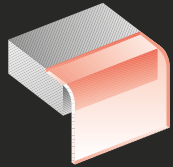

Inset mount

The most traditional method of installation. Simply insert from above into a prepared cut-out, and the rim of the sink sits on the work surface. Teka drop-in sinks can be mounted on virtually any worktop. The sink is fastened to the worktop from underneath, with no screws or bolts showing.

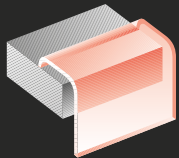

Lay on

Teka lay-on sinks are only superimposed, do not need, or use clips.

The stainless steel of the sink surrounds the edge of the countertop. Lay-on sinks can be delivered with wood supports at the sides (below the rim) to aid installation while providing structural reinforcement.

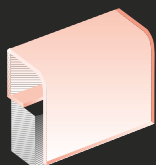





INSET 1 BOWL

SINKS



NEW

MAESTRO PURE CLEAN FLEXLINEA RS15 71.40

Ref. 115000054

- FlexLinea Stainless steel sink, One bowl
- PureClean waterproof effect
- SofTexture finish 3-in-1 installation: Inset/top, undermount & flush
- Easy clean radius R15 corners
- Decorative SQ cover, SilentSmart, 50% less noise
- 3 1/2" SQ manual basket waste and siphon
- 80 cm base unit
- Thickness: 1.0 mm
- Packaging: Individual carton box (Vol: 0.1 m³ – Wt: 7.3 kg)

INCLUDED ACCESSORIES

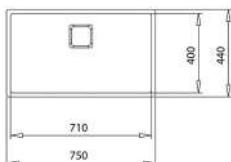

COLOR

■ Stainless Steel

PRODUCT DIMENSIONS

Sink (LxW) 750 x 440 mm
Bowl (LxWxD) 710 x 400 x 200 mm



MAESTRO FLEXLINEA RS15 71.40

Ref. 115000011

- PureLine stainless steel sink, One bowl
- Finish: Polished
- 3-in-1 installation: Inset/top, undermount & flush
- Easy clean radius R15 corners
- Decorative SQ cover
- SilentSmart, 50% less noise
- 80 cm base unit
- Thickness: 1.0 mm
- Packaging: Individual carton box (Vol: 0.1 m³ – Wt: 7.3 kg)

INCLUDED ACCESSORIES

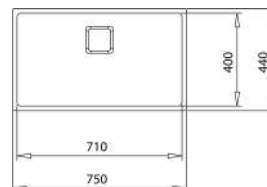

COLOR

■ Stainless Steel

PRODUCT DIMENSIONS

Sink (LxW) 750 x 440 mm
Bowl (LxWxD) 710 x 400 x 200 mm

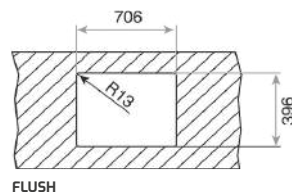

FLUSH



INSET/TOP

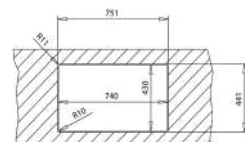

UNDERMOUNT

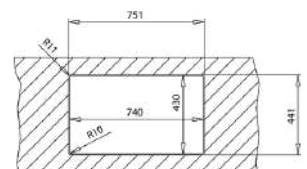

FLUSH

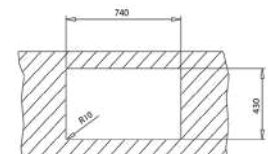

INSET/TOP

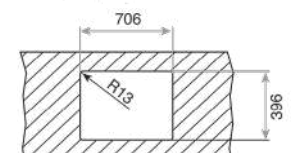

UNDERMOUNT



NEW

MAESTRO PURE CLEAN FLEXLINEA RS15 50.40

Ref. 115000046

- FlexLinea Stainless steel sink, One bowl
- PureClean waterproof effect
- SofTexture finish, 3-in-1 installation: Inset/top, undermount & flush, Easy clean radius R15 corners
- Decorative SQ cover, SilentSmart, 50% less noise
- 3 1/2" SQ manual basket waste and siphon
- 60 cm base unit
- Thickness: 1.0 mm
- Packaging: Individual carton box (Vol: 0.1 m³ – Wt: 5.4 kg)

INCLUDED ACCESSORIES

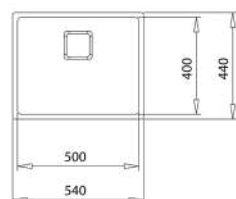

COLOR

■ Stainless Steel

PRODUCT DIMENSIONS

Sink (LxW) 540 x 440 mm
Bowl (LxWxD) 500 x 400 x 200 mm



Ref. 115000012

- PureLine stainless steel sink, One bowl
- Finish: Polished
- 3-in-1 installation: Inset/top, undermount & flush
- Easy clean radius R15 corners
- Decorative SQ cover
- SilentSmart, 50% less noise
- 60 cm base unit
- Thickness: 1.0 mm
- Packaging: Individual carton box (Vol: 0.1 m³ – Wt: 5.4 kg)

INCLUDED ACCESSORIES

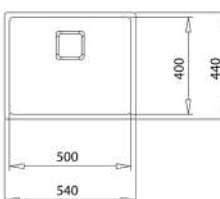

COLOR

■ Stainless Steel

PRODUCT DIMENSIONS

Sink (LxW) 540 x 440 mm
Bowl (LxWxD) 500 x 400 x 200 mm

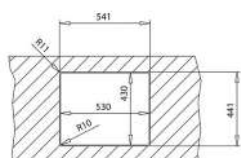

FLUSH

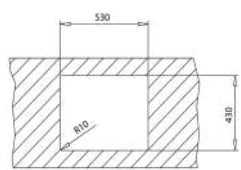

INSET/TOP

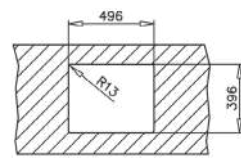

UNDERMOUNT

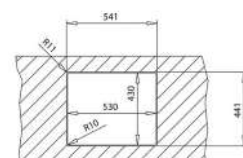

FLUSH

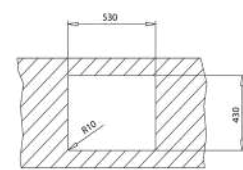

INSET/TOP

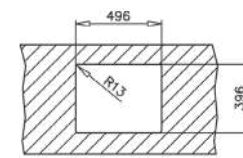

UNDERMOUNT

SINKS



MAESTRO FLEXPINEA RS15 50.40 BRASS

Ref. 115000023

- Metallic stainless steel + PVD coat sink, One Bowl
- Finish: Polished
- 3-in-1 installation: Inset/top, undermount & flush
- Easy clean radius R15 corners
- Decorative SQ cover
- SilentSmart, 50% less noise
- 60 cm base unit
- Thickness: 1.0 mm
- Packaging: Individual carton box (Vol: 0.1 m³ – Wt: 5 kg)

INCLUDED ACCESSORIES

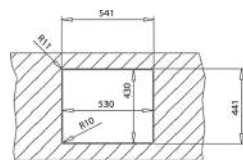

FLUSH

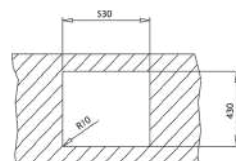

INSET/TOP

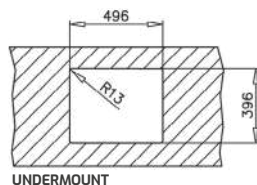

UNDERMOUNT

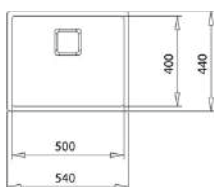

COLOR

 Brass

PRODUCT DIMENSIONS

Sink (LxW) 540 x 440 mm
Bowl (LxWxD) 500 x 400 x 200 mm

MAESTRO FLEXPINEA RS15 50.40 TITANIUM

Ref. 115000024

- Metallic stainless steel + PVD coat sink, One Bowl
- Finish: Polished
- 3-in-1 installation: Inset/top, undermount & flush
- Easy clean radius R15 corners
- Decorative SQ cover
- SilentSmart, 50% less noise
- 60 cm base unit
- Thickness: 1.0 mm
- Packaging: Individual carton box (Vol: 0.1 m³ – Wt: 5 kg)

INCLUDED ACCESSORIES

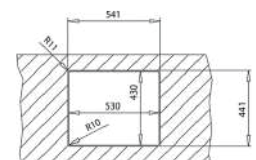

FLUSH

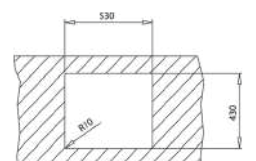

INSET/TOP

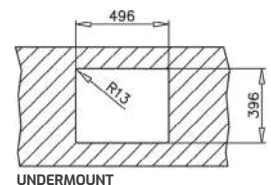

UNDERMOUNT

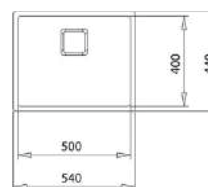

COLOR

 Titanium

PRODUCT DIMENSIONS

Sink (LxW) 540 x 440 mm
Bowl (LxWxD) 500 x 400 x 200 mm



NEW

MAESTRO PURE CLEAN FLEXLINEA RS15 40.40

Ref. 115000053

- FlexLinea Stainless steel sink, One bowl
- PureClean waterproof effect
- SofTexture finish, 3-in-1 installation: Inset/top, undermount & flush, Easy clean radius R15 corners
- Decorative SQ cover, SilentSmart, 50% less noise
- 3 1/2" SQ manual basket waste and siphon
- 50 cm base unit
- Thickness: 1.0 mm
- Packaging: Individual carton box (Vol: 0.1 m³ – Wt: 4.3 kg)

INCLUDED ACCESSORIES

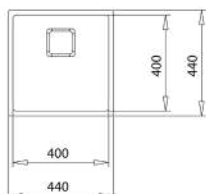
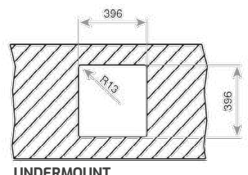
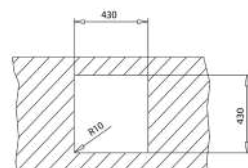
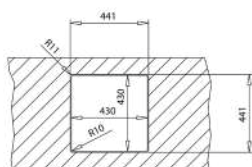

COLOR

■ Stainless Steel

PRODUCT DIMENSIONS

Sink (LxW) 440 x 440 mm
Bowl (LxWxD) 400 x 400 x 200 mm



MAESTRO FLEXLINEA RS15 40.40

Ref. 115000014

- PureLine stainless steel sink, One bowl
- Finish: Polished
- 3-in-1 installation: Inset/top, undermount & flush
- Easy clean radius R15 corners
- Decorative SQ cover
- SilentSmart, 50% less noise
- 50 cm base unit
- Thickness: 1.0 mm
- Packaging: Individual carton box (Vol: 0.1 m³ – Wt: 4.3 kg)

INCLUDED ACCESSORIES

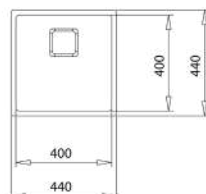
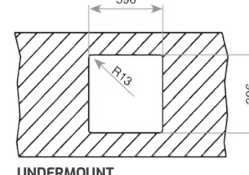
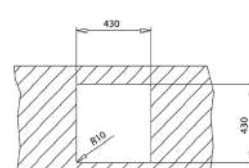
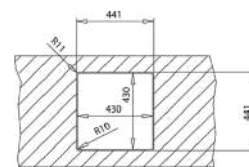

COLOR

■ Stainless Steel

PRODUCT DIMENSIONS

Sink (LxW) 440 x 440 mm
Bowl (LxWxD) 400 x 400 x 200 mm

SINKS



MAESTRO ZENIT RS15 1B

Ref. 115000021

- PureLine stainless steel sink, One bowl
- Inset installation
- Finish: Polished
- Easy clean radius R15 corners
- Decorative SQ cover
- SilentSmart, 50% less noise
- 60 cm base unit
- Thickness: 1.0 mm
- Packaging: Individual carton box (Vol: 0.1 m³ – Wt: 5.6 kg)

INCLUDED ACCESSORIES

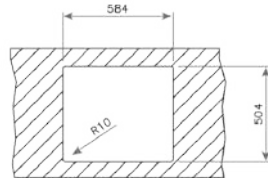
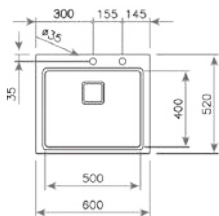

COLOR

■ Stainless Steel

PRODUCT DIMENSIONS

Sink (LxW) 600 x 520 mm
Bowl (LxWxD) 500 x 400 x 200 mm



NEW

MAESTRO BROOKLYN 50 M-XP 1B

Ref. 115000057

- Brooklyn Series
- Stainless steel sink, One bowl
- 2-in-1 installation possibilities: top or flush
- Finish: Polished
- V-control 3¹/₂" automatic waste basket with siphon
- SilentSmart, 50% less noise
- 50 cm base unit
- Thickness: 1.0 mm
- Packaging: Individual carton box (Vol: 0.1 m³ – Wt: 6.6 kg)

INCLUDED ACCESSORIES

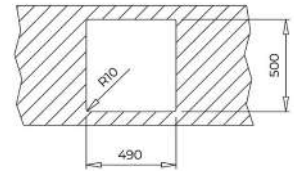
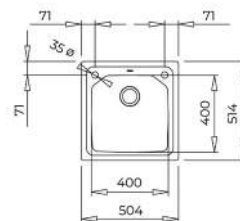

COLOR

■ Stainless Steel

PRODUCT DIMENSIONS

Sink (LxW) 504 x 514 mm
Bowl (LxWxD) 400 x 400 x 210 mm



TOTAL BAHIA 1B PLUS

Ref. 11127004

- Stainless steel sink, One bowl
- Finish: Polished
- Inset Installation
- 90 cm base unit
- Thickness: 0.8 mm
- Packaging: Individual carton box
(Vol: 0.1 m³ – Wt: 6.6 kg)

INCLUDED ACCESSORIES

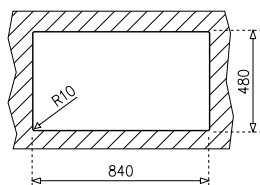
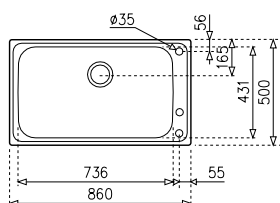

COLOR



Stainless Steel

PRODUCT DIMENSIONS

Sink (LxW) 860 x 500 mm
Bowl (LxWxD) 736 x 431 x 220 mm

TOTAL STYLO 1B

Ref. 10107074

- Stainless steel sink, One bowl
- Finish: Polished
- Inset Installation
- 45 cm base unit
- Thickness: 0.7mm
- Packaging: Individual carton box
(Vol: 0.1 m³ – Wt: 2.8 kg)

INCLUDED ACCESSORIES

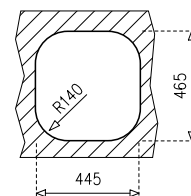
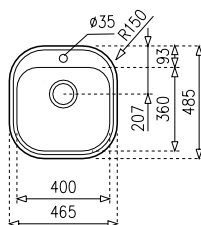

COLOR



Stainless Steel

PRODUCT DIMENSIONS

Sink (LxW) 465 x 485 mm
Bowl (LxWxD) 400 x 365 x 165 mm

SINKS



EASY STARBRIGHT 50 E-XN 1B

Ref. 115020007

- Stainless steel sink, One bowl
- Finish: Matt
- Inset installation
- 50 cm base unit
- Thickness: 0.7 mm
- Packaging: Individual carton box (Vol: 0.1 m³ – Wt: 3.3 kg)

INCLUDED ACCESSORIES



Available in pallet with cardboard protection for bulk orders :

Ref (Sink without accessories): 115020005
 Ref (Accessories same as above): 61001293
 Units per pallet: 240 units, Min. order 1 Pallet
 (Vol: 2 m³)

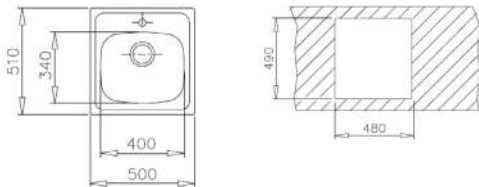

COLOR

■ Stainless Steel

PRODUCT DIMENSIONS

Sink (LxW) 500 x 510 mm
 Bowl (LxWxD) 400 x 340 x 150 mm

EASY STARBRIGHT 45 E-XN 1B

Ref. 115020011

- Stainless steel sink, One bowl
- Finish: Matt
- Inset installation
- 45 cm base unit
- Thickness: 0.6 mm
- Packaging: Individual carton box (Vol: 0.1 m³ – Wt: 2.4 kg)

INCLUDED ACCESSORIES



Available in pallet with cardboard protection for bulk orders :

Ref (Sink without accessories): 115020012
 Ref (Accessories same as above): 61001293
 Units per pallet: 210 units, Min. order 1 Pallet
 (Vol: 2 m³)

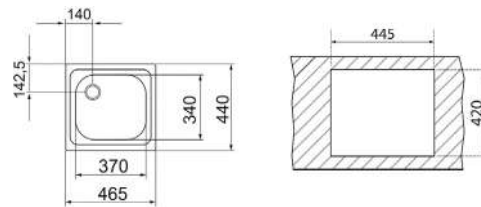

COLOR

■ Stainless Steel

PRODUCT DIMENSIONS

Sink (LxW) 465 x 440 mm
 Bowl (LxWxD) 370 x 340 x 150 mm



EASY CENTROVAL 1B

Ref. 10111903

- Stainless steel sink, One bowl
- Finish: Polished
- Inset Installation
- 45 cm base unit
- Thickness: 0.8mm
- Packaging: Individual carton box
(Vol: 0.1 m³ – Wt: 3 kg)

INCLUDED ACCESSORIES



Available in pallet with cardboard protection for bulk orders :

Ref (Sink without accessories): 10111012
 Ref (Accessories same as above): 61001293
 Units per pallet: 100 units, Min. order 1 Pallet
 (Vol: 2.1 m³)

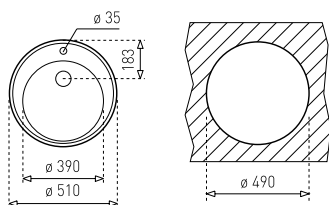

COLOR

■ Stainless Steel

PRODUCT DIMENSIONS

Sink (Ø) 510 mm
 Bowl (ØxD) 390 x 180 mm

EASY STARBRIGHT 45 E-XN 1B ORB

Ref. 115020008

- Stainless steel sink, One bowl
- Finish: Matt
- Inset installation
- 50 cm base unit
- Thickness: 0.6 mm
- Packaging: Individual carton box
(Vol: 0.1 m³ – Wt: 2.5 kg)

INCLUDED ACCESSORIES



Available in pallet with cardboard protection for bulk orders :

Ref (Sink without accessories): 115020009
 Ref (Accessories same as above): 61001293
 Units per pallet: 100 units, Min. order 1 Pallet
 (Vol: 2.1 m³)

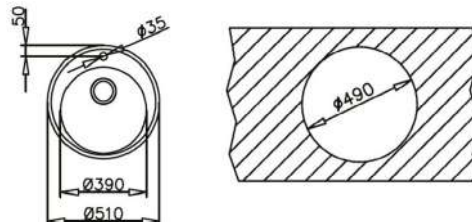

COLOR

■ Stainless Steel

PRODUCT DIMENSIONS

Sink (Ø) 510 mm
 Bowl (ØxD) 390 x 160 mm

SINKS



EASY ERC 1B

Ref. 10108007

- Stainless steel sink, One bowl
- Finish: Polished
- Inset Installation
- 45 cm base unit,
- Thickness: 0.8mm
- Packaging: Individual carton box (Vol: 0.1 m³ – Wt: 2.4 kg)

INCLUDED ACCESSORIES



Available in pallet with cardboard protection for bulk orders :

Ref (Sink without accessories): 10108025
 Ref (Accessories same as above): 61001293
 Units per pallet: 100 units, Min. order 1 Pallet
 (Vol: 2.1 m³)

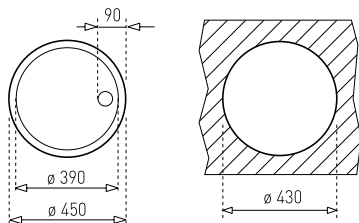

COLOR

■ Stainless Steel

PRODUCT DIMENSIONS

Sink (Ø) 450 mm
 Bowl (ØxD) 390 x 180 mm

EASY STARBRIGHT 45 E-XN 1B RND

Ref. 115020013

- Stainless steel sink, One bowl
- Finish: Matt
- 2-in-1 installation: inset or undermount
- 45 cm base unit
- Thickness: 0.6 mm
- Packaging: Cardboard protection (Vol: 2.1 m³)

Below accessories to order

Ref : 61001293
 (Included in the price of the sink)

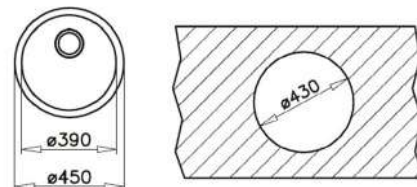

COLOR

■ Stainless Steel

PRODUCT DIMENSIONS

Sink (Ø) 450 mm
 Bowl (ØxD) 390 x 160 mm



INSET 1 BOWL 1 DRAINER

SINKS



MAESTRO DIAMOND R515 1B 1D 86 AUTO BK

Ref. 115100011

- Urban Colors Edition
- PureLine glass sink, 1 inox bowl and 1 drainer
- Finish: Polished, Inset installation, Reversible drainer
- Safety tempered glass with bevelled edges, impact resistance, high temperatures and thermal shocks
- Easy clean radius R15 corners
- Decorative SQ cover
- SilentSmart, 50% less noise
- 50 cm base unit
- Thickness: 8.0 mm top / 1.0 mm bowl
- Packaging: Individual carton box (Vol: 0.2 m³ – Wt: 6.1 kg)

INCLUDED ACCESSORIES

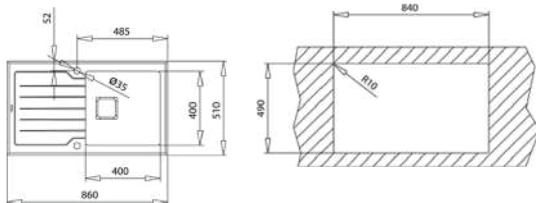

COLOR

 Black Glass

PRODUCT DIMENSIONS

Sink (LxW) 860 x 510 mm
Bowl (LxWxD) 400 x 400 x 200 mm

MAESTRO DIAMOND R515 1B 1D 86 AUTO WH

Ref. 115100012

- Urban Colors Edition
- PureLine glass sink, 1 inox bowl and 1 drainer
- Finish: Polished, Inset installation, Reversible drainer
- Safety tempered glass with bevelled edges, impact resistance, high temperatures and thermal shocks
- Easy clean radius R15 corners
- Decorative SQ cover
- SilentSmart, 50% less noise
- 50 cm base unit
- Thickness: 8.0 mm top / 1.0 mm bowl
- Packaging: Individual carton box (Vol: 0.2 m³ – Wt: 6.1 kg)

INCLUDED ACCESSORIES

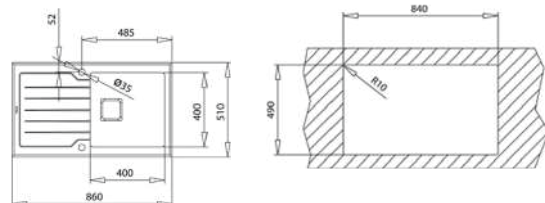

COLOR

 White Glass

PRODUCT DIMENSIONS

Sink (LxW) 860 x 510 mm
Bowl (LxWxD) 400 x 400 x 200 mm



MAESTRO ZENIT RS15 1B 1D 86

Ref. 115100003

- PureLine stainless steel sink
- 1 bowl and 1 drainer, right hand
- Finish: Polished
- Inset Installation
- Easy clean radius R15 corners
- Decorative SQ cover
- SilentSmart, 50% less noise
- 50 cm base unit
- Thickness: 1.0 mm
- Packaging: Individual carton box
(Vol: 0.1 m³ – Wt: 6.6 kg)

INCLUDED ACCESSORIES

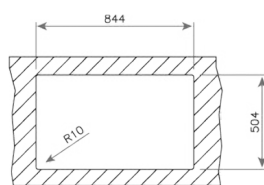
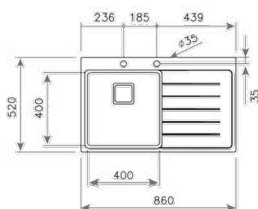

COLOR

■ Stainless Steel

PRODUCT DIMENSIONS

Sink (LxW) 860 x 520 mm
Bowl (LxWxD) 400 x 400 x 200 mm

NEW

MAESTRO BROOKLYN 60 M-XP 1B 1D PLUS

Ref. 115100023

- Brooklyn Series
- Stainless steel sink, One bowl and one drainer
- 2-in-1 installation possibilities: top or flush
- Finish: Polished
- V-control 3 1/2" automatic waste basket with siphon
- New HelixPRO waste basket
- 60 cm base unit
- Thickness: 1.0 mm
- Packaging: Individual carton box
(Vol: 0.1 m³ – Wt: 6.8 kg)

INCLUDED ACCESSORIES

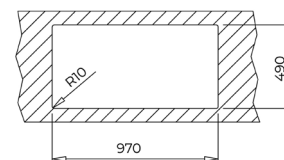
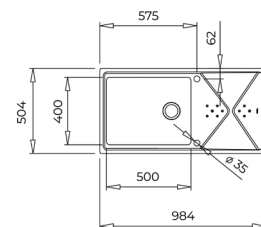

COLOR

■ Stainless Steel

PRODUCT DIMENSIONS

Sink (LxW) 984 x 504 mm
Bowl (LxWxD) 500 x 400 x 210 mm

SINKS



TOTAL CLASSIC MAX 1B 1D

Ref. 11119200

- Stainless steel sink, One bowl and One drainer Right Hand
- Finish: Polished
- Inset Installation
- 50 cm base unit
- Thickness: 0.8 mm top / 1.0 mm bowl
- Packaging: Individual carton box
(Vol: 0.1 m³ – Wt: 6.8 kg)

INCLUDED ACCESSORIES

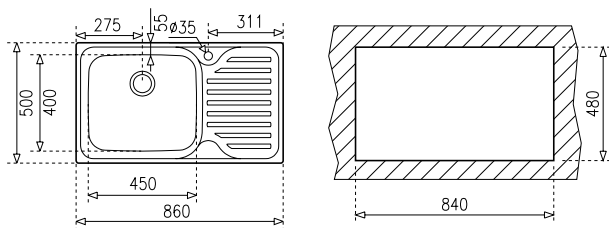

COLOR

■ Stainless Steel

PRODUCT DIMENSIONS

Sink (LxW) 860 x 500 mm
Bowl (LxWxD) 450 x 400 x 200 mm

TOTAL CLASSIC 1B 1D

Ref. 10119013

- Stainless steel sink, One bowl and One drainer
- Finish: Polished
- Inset installation, Reversible drainer
- 50 cm base unit
- Thickness: 0.8 mm
- Packaging: Individual carton box
(Vol: 0.1 m³ – Wt: 5.4 kg)

INCLUDED ACCESSORIES



Available in pallet with cardboard protection for bulk orders :

Ref (Sink without accessories): 10119056
Ref (Accessories same as above): 61001403
Units per pallet: 90 units, Min. order 1 Pallet
(Vol: 2 m³)

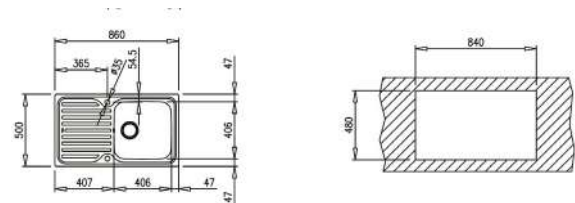

COLOR

■ Stainless Steel

PRODUCT DIMENSIONS

Sink (LxW) 860 x 500 mm
Bowl (LxWxD) 406 x 406 x 190 mm



TOTAL UNIVERSE 50 T-XP 1B 1D PLUS

Ref. 115110022

- Stainless steel sink, One bowl and one drainer
- Finish: Polished
- Inset installation, Reversible drainer
- 50 cm base unit
- Thickness: 0.8 mm
- Packaging: Individual carton box (Vol: 0.1 m³ – Wt: 5.4 kg)

INCLUDED ACCESSORIES



Available in pallet with cardboard protection for bulk orders :

Ref (Sink without accessories): 115110025
 Ref (Accessories same as above): 61001403
 Units per pallet: 90 units, Min. order 1 Pallet
 (Vol: 2 m³)

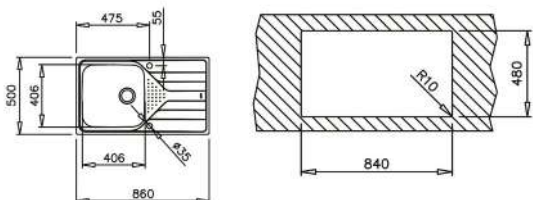

COLOR

■ Stainless Steel

PRODUCT DIMENSIONS

Sink (LxW) 860 x 500 mm
 Bowl (LxWxD) 406 x 406 x 195 mm

EASY STARBRIGHT 50 E-XN 1B 1D

Ref. 115120028

- Stainless steel sink, One bowl and one drainer
- Finish: Matt
- Inset installation, Reversible drainer
- 50 cm base unit
- Thickness: 0.7 mm
- Packaging: Individual carton box (Vol: 0.1 m³ – Wt: 4.9 kg)

INCLUDED ACCESSORIES



Available in pallet with cardboard protection for bulk orders :

Ref (Sink without accessories): 115120031
 Ref (Accessories same as above): 61001293
 Units per pallet: 90 units, Min. order 1 Pallet
 (Vol: 2 m³)

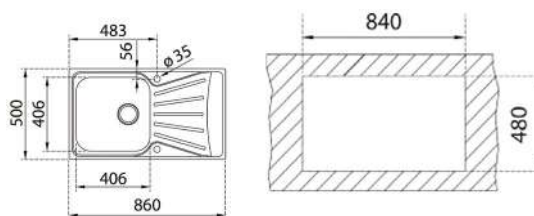

COLOR

■ Stainless Steel

PRODUCT DIMENSIONS

Sink (LxW) 860 x 500 mm
 Bowl (LxWxD) 406 x 406 x 170 mm

SINKS



EASY STARBRIGHT 45 E-XN 1B 1D

Ref. 115120037

- Stainless steel sink, One bowl and one drainer
- Finish: Matt
- Inset installation, Reversible drainer
- 45 cm base unit
- Thickness: 0.6 mm
- Packaging: Individual carton box (Vol: 0.1 m³ – Wt: 4.2 kg)

INCLUDED ACCESSORIES



Available in pallet with cardboard protection for bulk orders :

Ref (Sink without accessories): 115120038
 Ref (Accessories same as above): 61001293
 Units per pallet: 105 units, Min. order 1 Pallet
 (Vol: 1.9 m³)

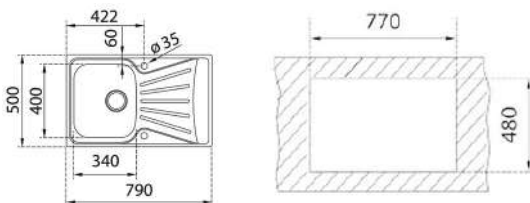

COLOR

■ Stainless Steel

PRODUCT DIMENSIONS

Sink (LxW) 790 x 500 mm
 Bowl (LxWxD) 340 x 400 x 160 mm

EASY DEVA 45 I-CN 1B 1D

Ref. 10133005

- Stainless steel sink, One bowl and One drainer
- Finish: Matt
- Inset installation, Reversible drainer
- 45 cm base unit
- Thickness: 0.5 mm
- Packaging information: Carboard Protection (Vol: 1 m³)

Below accessories to order

Ref : 61001300, 61001313
 (Included in the price of the sink)

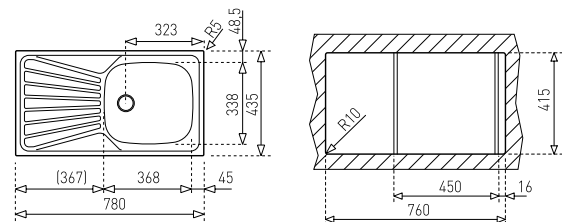

COLOR

■ Stainless Steel

PRODUCT DIMENSIONS

Sink (LxW) 780 x 435 mm
 Bowl (LxWxD) 368 x 338 x 146 mm



INSET 1¹/₂B-1D

INSET 1¹/₂ BOWL 1 DRAINER

SINKS



TOTAL UNIVERSE 60 T-XP 1½/2B 1D

Ref. 115140001

- Stainless steel sink, One bowl, one auxiliary bowl and one drainer
- Finish: Polished
- Inset installation, Reversible drainer
- 60 cm base unit
- Thickness: 0.7 mm
- Packaging: Individual carton box (Vol: 0.1 m³ – Wt: 5.6 kg)

INCLUDED ACCESSORIES



Available in pallet with cardboard protection for bulk orders :

Ref (Sink without accessories): 115140002
 Ref (Accessories same as above): 61001404
 Units per pallet: 90 units, Min. order 1 Pallet
 (Vol: 2 m³)

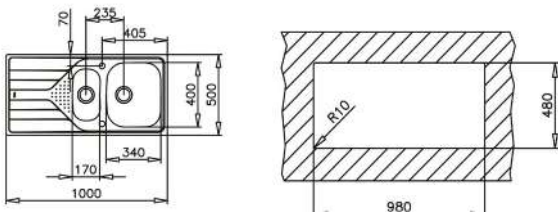

COLOR

■ Stainless Steel

PRODUCT DIMENSIONS

Sink (LxW) 1000 x 500 mm
 Bowl 1 (LxWxD) 340 x 400 x 160 mm
 Bowl 2 (LxWxD) 170 x 320 x 110 mm



EASY STARBRIGHT 60 E-XN 1½/2B 1D

Ref. 115150002

- Stainless steel sink, One bowl, one auxiliary bowl and one drainer
- Finish: Matt
- Inset installation, Reversible drainer
- 60 cm base unit
- Thickness: 0.6 mm
- Packaging: Individual carton box (Vol: 0.1 m³ – Wt: 5.1 kg)

INCLUDED ACCESSORIES



Available in pallet with cardboard protection for bulk orders :

Ref (Sink without accessories): 115150003
 Ref (Accessories same as above): 61001294
 Units per pallet: 90 units, Min. order 1 Pallet
 (Vol: 2 m³)

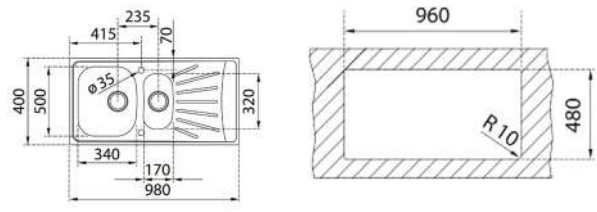

COLOR

■ Stainless Steel

PRODUCT DIMENSIONS

Sink (LxW) 980 x 500 mm
 Bowl 1 (LxWxD) 340 x 400 x 160 mm
 Bowl 2 (LxWxD) 170 x 320 x 100 mm



INSET 2B-2¹/₂B

INSET 2 BOWL 2¹/₂ BOWLS

SINKS



MAESTRO ZENIT RS15 2B 86

Ref. 115030015

- PureLine stainless steel sink, Two bowls
- Finish: Polished
- Inset installation
- Easy clean radius R15 corners, Decorative SQ cover
- SilentSmart, 50% less noise
- 90 cm base unit
- Thickness: 1.0 mm
- Packaging: Individual carton box
(Vol: 0.1 m³ – Wt: 8.8 kg)

INCLUDED ACCESSORIES

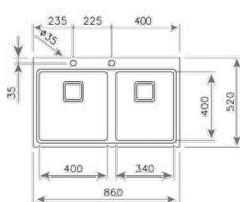

COLOR

■ Stainless Steel

PRODUCT DIMENSIONS

Sink (LxW) 860 x 520 mm
 Bowl 1 (LxWxD) 400 x 400 x 200 mm
 Bowl 2 (LxWxD) 340 x 400 x 200 mm



NEW

MAESTRO BROOKLYN 90 M-XP 2B

Ref. 115030024

- Brooklyn Series
- Stainless steel sink, Two bowls, reversible
- Finish: Polished
- 2-in-1 installation possibilities: top or flush
- V-control 3¹/₂" automatic waste basket with siphon
- New HelixPRO waste basket
- SilentSmart, 50% less noise
- 90 cm base unit
- Thickness: 1.0 mm
- Packaging: Individual carton box
(Vol: 0.1 m³ – Wt: 6.2 kg)

INCLUDED ACCESSORIES

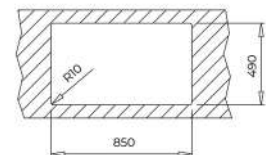
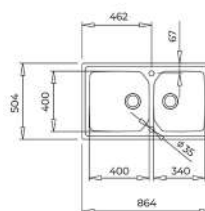

COLOR

■ Stainless Steel

PRODUCT DIMENSIONS

Sink (LxW) 864 x 504 mm
 Bowl 1&2 (LxWxD) 400 x 400 x 210 mm



TOTAL CLASSIC 2B 86

Ref. 10119021

- Stainless steel sink, Two bowls
- Finish: Polished
- Inset installation
- 90 cm base unit
- Thickness: 0.8 mm
- Packaging: Individual carton box (Vol: 0.1 m³ – Wt: 7 kg)

INCLUDED ACCESSORIES

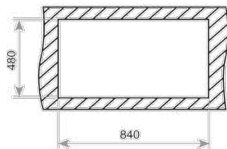
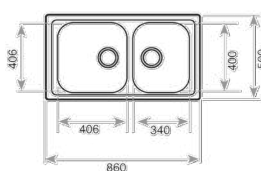

COLOR

■ Stainless Steel

PRODUCT DIMENSIONS

Sink (LxW) 860 x 500 mm
 Bowl 1 (LxWxD) 406 x 406 x 190 mm
 Bowl 2 (LxWxD) 340 x 400 x 190 mm

TOTAL UNIVERSE 80 T-XP 2B

Ref. 115040007

- Stainless steel sink, Two bowls
- Finish: Polished
- Inset installation
- 80 cm base unit
- Thickness: 0.7 mm
- Packaging: Individual carton box (Vol: 0.1 m³ – Wt: 5.2 kg)

INCLUDED ACCESSORIES



Available in pallet with cardboard protection for bulk orders :

Ref (Sink without accessories): 115040009
 Ref (Accessories same as above): 61001404
 Units per pallet: 90 units, Min. order 1 Pallet (Vol: 1.9 m³)

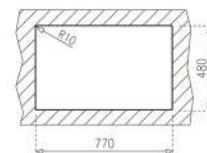
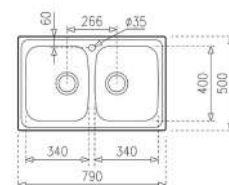

COLOR

■ Stainless Steel

PRODUCT DIMENSIONS

Sink (LxW) 790 x 500 mm
 Bowl 1&2 (LxWxD) 340 x 400 x 170 mm

SINKS



EASY STARBRIGHT 80 E-XN 2B

Ref. 115050003

- Stainless steel sink, Two bowls
- Finish: Matt
- Inset installation
- 80 cm base unit
- Thickness: 0.5 mm
- Packaging: Individual carton box (Vol: 0.1 m³ – Wt: 3.8 kg)

INCLUDED ACCESSORIES



Available in pallet with cardboard protection for bulk orders :

Ref (Sink without accessories): 115050004
 Ref (Accessories same as above): 61001294
 Units per pallet: 105 units, Min. order 1 Pallet
 (Vol: 1.9 m³)

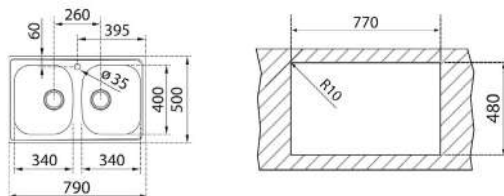

COLOR

■ Stainless Steel

PRODUCT DIMENSIONS

Sink (LxW) 790 x 500 mm
 Bowl 1&2 (LxWxD) 340 x 400 x 160 mm

TOTAL CLASSIC 2 1/2 B

Ref. 10119080

- Stainless steel sink, Two bowls and 1 auxiliary bowl
- Finish: Polished
- Inset installation
- 100 cm base unit
- Thickness: 0.8 mm
- Packaging: Individual carton box (Vol: 0.1 m³ – Wt: 8.2 kg)

INCLUDED ACCESSORIES

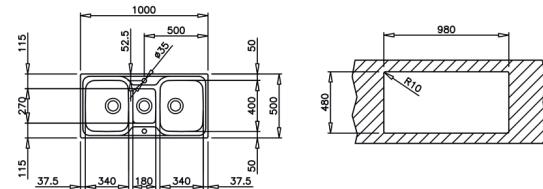

COLOR

■ Stainless Steel

PRODUCT DIMENSIONS

Sink (LxW) 1000 x 500 mm
 Bowl 1&2 (LxWxD) 340 x 400 x 190 mm
 Bowl 3 (LxWxD) 180 x 270 x 135 mm

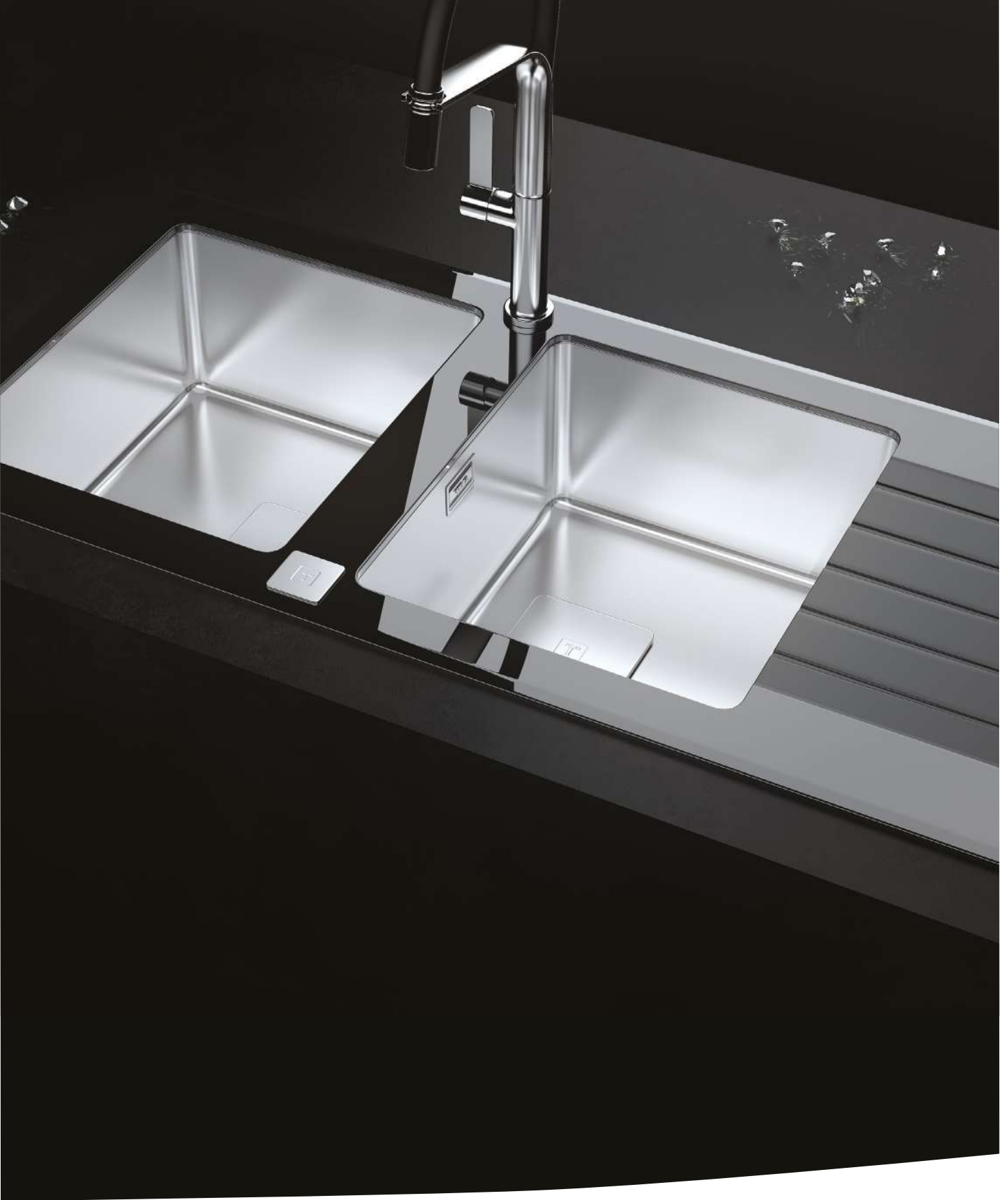

2B-1D, 2 1/2B-1D

INSET 2 BOWLS 1 DRAINER

SINKS



MAESTRO DIAMOND RS15 2B 1D AUTO

Ref. 115160007

- PureLine glass and stainless steel sink
- Two bowls and one drainer
- Safety tempered glass with bevelled edges, impact resistance, high temperatures and thermal shocks
- Inset installation, Reversible drainer
- Easy clean radius R15 corners, Decorative SQ cover
- SilentSmart, 50% less noise
- 80 cm base unit
- Thickness: 8.0 mm top / 1.0 mm bowl
- Packaging: Individual carton box (Vol: 0.2 m³ – Wt: 8.6 kg)

INCLUDED ACCESSORIES

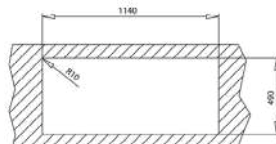
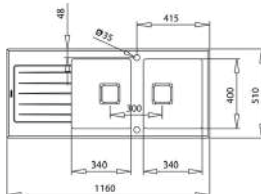

COLOR

■ Stainless Steel

PRODUCT DIMENSIONS

Sink (LxW) 1160 x 510 mm
Bowl 1&2 (LxWxD) 340 x 400 x 200 mm

MAESTRO ZENIT RS15 2B 1D R AUTO

Ref. 115160003

- PureLine stainless steel sink
- 2 bowls and 1 drainer, right hand
- Finish: Polished
- Inset installation
- Easy clean radius R15 corners, Decorative SQ cover
- SilentSmart, 50% less noise
- 80 cm base unit
- Thickness: 1.0 mm
- Packaging: Individual carton box (Vol: 0.2 m³ – Wt: 9.7 kg)

INCLUDED ACCESSORIES

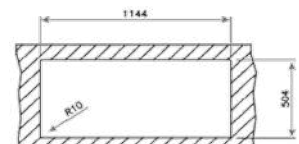
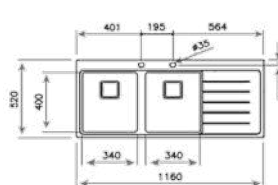

COLOR

■ Stainless Steel

PRODUCT DIMENSIONS

Sink (LxW) 1160 x 520 mm
Bowl 1&2 (LxWxD) 340 x 400 x 200 mm



NEW

MAESTRO BROOKLYN 80 M-XP 2B 1D

Ref. 115160010

- Brooklyn Series
- Stainless steel sink, Two bowls and one drainer, reversible
- Finish: Polished
- 2-in-1 installation possibilities: top or flush
- V-control 3 1/2" automatic waste basket with siphon
- New HelixPRO waste basket
- SilentSmart, 50% less noise
- 80 cm base unit
- Thickness: 1.0 mm
- Packaging: Individual carton box (Vol: 0.2 m³ – Wt: 7.8 kg)

INCLUDED ACCESSORIES



White glass chopping board

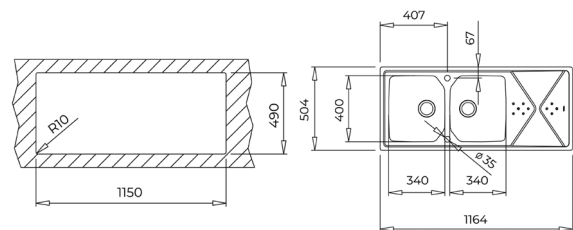

COLOR

■ Stainless Steel

PRODUCT DIMENSIONS

Sink (LxW) 1164 x 504 mm
Bowl 1&2 (LxWxD) 340 x 400 x 210 mm



TOTAL CLASSIC 2B 1D

Ref. 10119023

- Stainless steel sink, Two bowls and One drainer
- Finish: Polished
- Inset installation, Reversible drainer
- 80 cm base unit
- Thickness: 0.8 mm
- Packaging: Individual carton box (Vol: 0.1 m³ – Wt: 8.6 kg)

INCLUDED ACCESSORIES



Available in pallet with cardboard protection for bulk orders :

Ref (Sink without accessories): 10119085
Ref (Accessories same as above): 61001404
Units per pallet: 40 units, Min. order 1 Pallet
(Vol: 1.6 m³)

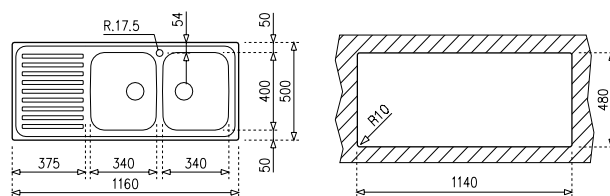

COLOR

■ Stainless Steel

PRODUCT DIMENSIONS

Sink (LxW) 1160 x 500 mm
Bowl 1&2 (LxWxD) 340 x 400 x 190 mm

2B-1D, 2 1/2B-1D

SINKS



TOTAL UNIVERSE 80 T-XP 2B 1D

Ref. 115170001

- Stainless steel sink, Two bowls and one drainer
- Finish: Polished
- Inset installation, Reversible drainer
- 80 cm base unit
- Thickness: 0.7 mm
- Packaging: Individual carton box (Vol: 0.1 m³ – Wt: 6.7 kg)

INCLUDED ACCESSORIES



Available in pallet with cardboard protection for bulk orders :

Ref (Sink without accessories): 115170002
 Ref (Accessories same as above): 61001404
 Units per pallet: 90 units, Min. order 1 Pallet
 (Vol: 2 m³)

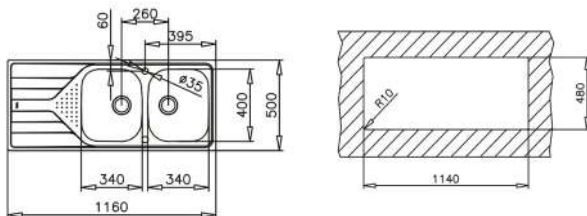

COLOR

■ Stainless Steel

PRODUCT DIMENSIONS

Sink (LxW) 1160 x 500 mm
 Bowl 1&2 (LxWxD) 340 x 400 x 170 mm



EASY STARBRIGHT 80 E-XN 2B 1D

Ref. 115180002

- Stainless steel sink, Two bowls and one drainer
- Finish: Matt
- Inset installation, Reversible drainer
- 80 cm base unit
- Thickness: 0.6 mm
- Packaging: Individual carton box (Vol: 0.1 m³ – Wt: 6.1 kg)

INCLUDED ACCESSORIES



Available in pallet with cardboard protection for bulk orders :

Ref (Sink without accessories): 115180005
 Ref (Accessories same as above): 61001294
 Units per pallet: 90 units, Min. order 1 Pallet
 (Vol: 2 m³)

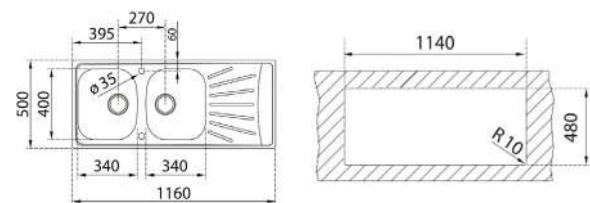

COLOR

■ Stainless Steel

PRODUCT DIMENSIONS

Sink (LxW) 1160 x 500 mm
 Bowl 1&2 (LxWxD) 340 x 400 x 160 mm



TOTAL ANGULAR 2B

Ref. 10118005

- Stainless steel sink, Two bowls and One drainer
- Finish: Polished
- Inset installation, Corner
- 90 cm base unit
- Thickness: 0.8 mm
- Packaging: Individual carton box (Vol: 0.2 m³ – Wt: 8.9 kg)

INCLUDED ACCESSORIES



TOTAL CLASSIC 2 1/2 B 1D

Ref. 10119081

- Stainless steel sink, Two bowls One auxiliary bowl and One drainer
- Finish: Polished
- Inset installation, Reversible drainer
- 100 cm base unit
- Thickness: 0.8 mm
- Packaging: Individual carton box (Vol: 0.2 m³ – Wt: 10.3 kg)

INCLUDED ACCESSORIES

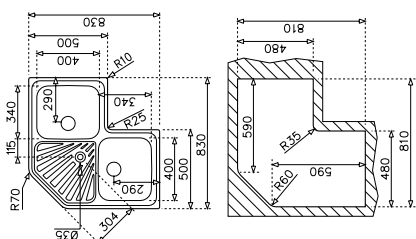

COLOR

■ Stainless Steel

PRODUCT DIMENSIONS

Sink (LxW) 830 x 830 mm
Bowl 1&2 (LxWxD) 340 x 400 x 190 mm

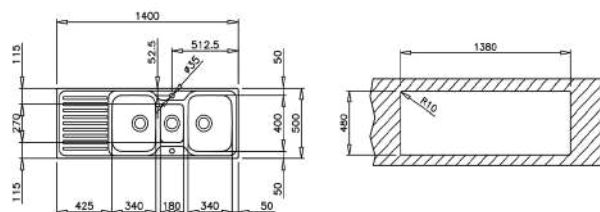

COLOR

■ Stainless Steel

PRODUCT DIMENSIONS

Sink (LxW) 1400 x 500 mm
Bowl 1&2 (LxWxD) 340 x 400 x 190 mm
Bowl 3 (LxWxD) 180 x 270 x 135 mm



UNDERMOUNT



NEW

MAESTRO PURE CLEAN FLEXLINA RS15 71.40

Ref. 115000054

- FlexLinea Stainless steel sink, One bowl
- PureClean waterproof effect
- SofTexture finish 3-in-1 installation: Inset/top, undermount & flush
- Easy clean radius R15 corners
- Decorative SQ cover, SilentSmart, 50% less noise
- 3 1/2" SQ manual basket waste and siphon
- 80 cm base unit
- Thickness: 1.0 mm
- Packaging: Individual carton box (Vol: 0.1 m³ – Wt: 7.3 kg)

INCLUDED ACCESSORIES

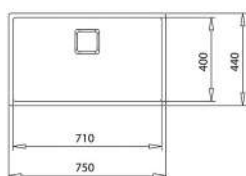
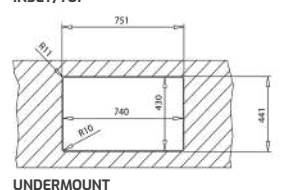
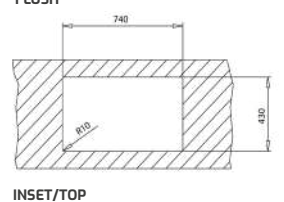
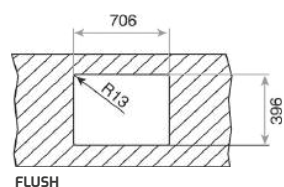

COLOR

■ Stainless Steel

PRODUCT DIMENSIONS

Sink (LxW) 750 x 440 mm
Bowl (LxWxD) 710 x 400 x 200 mm



MAESTRO FLEXLINA RS15 71.40

Ref. 115000011

- PureLine stainless steel sink, One bowl
- Finish: Polished
- 3-in-1 installation: Inset/top, undermount & flush
- Easy clean radius R15 corners
- Decorative SQ cover
- SilentSmart, 50% less noise
- 80 cm base unit
- Thickness: 1.0 mm
- Packaging: Individual carton box (Vol: 0.1 m³ – Wt: 7.3 kg)

INCLUDED ACCESSORIES

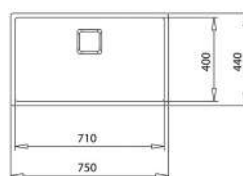
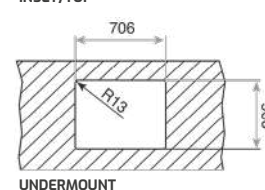
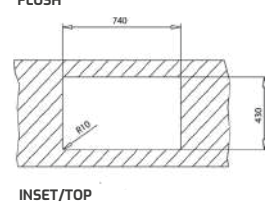
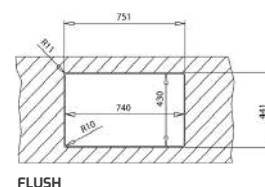

COLOR

■ Stainless Steel

PRODUCT DIMENSIONS

Sink (LxW) 750 x 440 mm
Bowl (LxWxD) 710 x 400 x 200 mm

SINKS



MAESTRO BE LINEA RS15 71.40

Ref. 115000004

- PureLine stainless steel sink, One bowl
- Finish: Polished
- Undermount installation
- Easy clean radius R15 corners
- SilentSmart, 50% less noise
- 80 cm base unit
- Thickness: 1.0 mm
- Packaging: Individual carton box
(Vol: 0.1 m³ – Wt: 7 kg)

INCLUDED ACCESSORIES

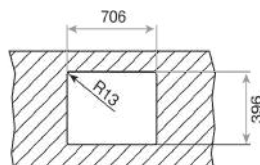
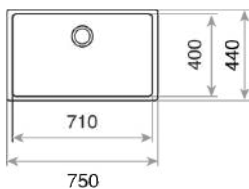

COLOR

■ Stainless Steel

PRODUCT DIMENSIONS

Sink (LxW) 750 x 440 mm
Bowl (LxWxD) 710 x 400 x 200 mm



NEW

MAESTRO PURE CLEAN FLEXLINEA RS15 50.40

Ref. 115000046

- FlexLinea Stainless steel sink, One bowl
- PureClean waterproof effect
- SofTexture finish, 3-in-1 installation: Inset/top, undermount & flush, Easy clean radius R15 corners
- Decorative SQ cover, SilentSmart, 50% less noise 3 1/2" SQ manual basket waste and siphon
- 60 cm base unit
- Thickness: 1.0 mm
- Packaging: Individual carton box
(Vol: 0.1 m³ – Wt: 5.4 kg)

INCLUDED ACCESSORIES

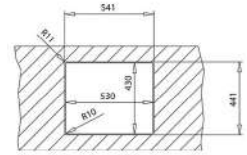

FLUSH

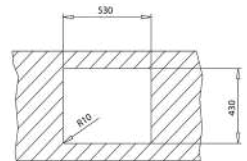

INSET/TOP

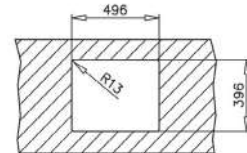

UNDERMOUNT

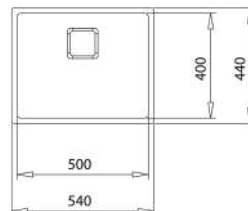

COLOR

■ Stainless Steel

PRODUCT DIMENSIONS

Sink (LxW) 540 x 440 mm
Bowl (LxWxD) 500 x 400 x 200 mm



MAESTRO FLEXLINEA RS15 50.40 BRASS

Ref. 115000023

- Metallic stainless steel + PVD coat sink, One Bowl
- Finish: Polished
- 3-in-1 installation: Inset/top, undermount & flush
- Easy clean radius R15 corners
- Decorative SQ cover
- SilentSmart, 50% less noise
- 60 cm base unit
- Thickness: 1.0 mm
- Packaging: Individual carton box (Vol: 0.1 m³ – Wt: 5 kg)

INCLUDED ACCESSORIES

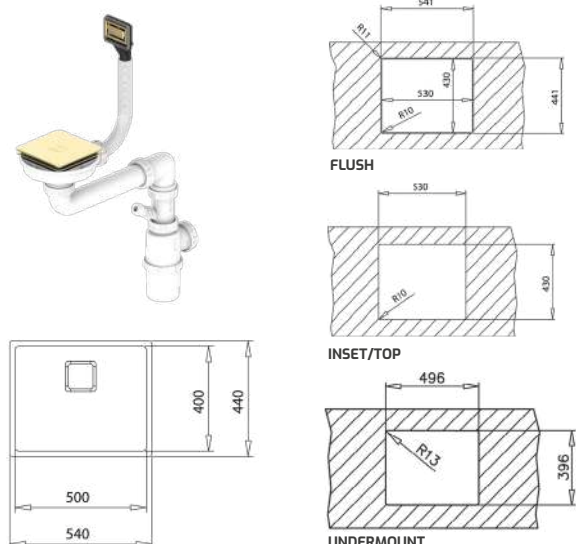

COLOR



PRODUCT DIMENSIONS

Sink (LxW) 540 x 440 mm
 Bowl (LxWxD) 500 x 400 x 200 mm

MAESTRO FLEXLINEA RS15 50.40 TITANIUM

Ref. 115000024

- Metallic stainless steel + PVD coat sink, One Bowl
- Finish: Polished
- 3-in-1 installation: Inset/top, undermount & flush
- Easy clean radius R15 corners,
- Decorative SQ cover
- SilentSmart, 50% less noise
- 60 cm base unit
- Thickness: 1.0 mm
- Packaging: Individual carton box (Vol: 0.1 m³ – Wt: 5 kg)

INCLUDED ACCESSORIES

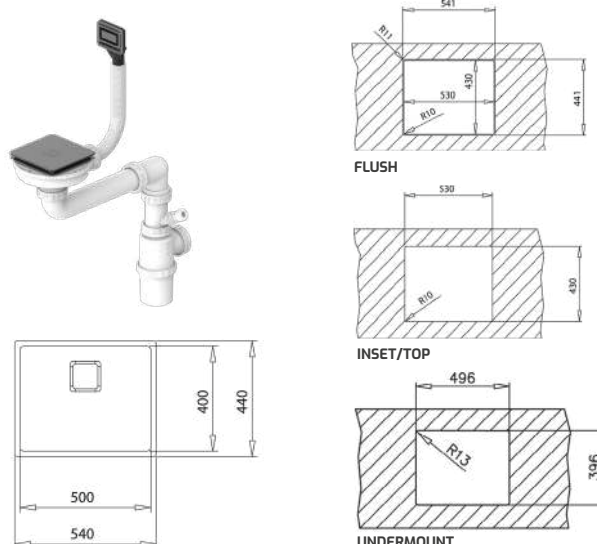

COLOR



PRODUCT DIMENSIONS

Sink (LxW) 540 x 440 mm
 Bowl (LxWxD) 500 x 400 x 200 mm

SINKS



MAESTRO FLEXLINEA RS15 50.40

Ref. 115000012

- PureLine stainless steel sink, One bowl
- Finish: Polished
- 3-in-1 installation: Inset/top, undermount & flush
- Easy clean radius R15 corners
- Decorative SQ cover
- SilentSmart, 50% less noise
- 60 cm base unit
- Thickness: 1.0 mm
- Packaging: Individual carton box
(Vol: 0.1 m³ – Wt: 5.4 kg)

INCLUDED ACCESSORIES

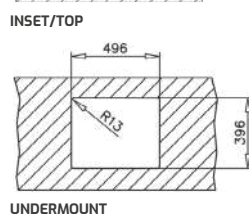
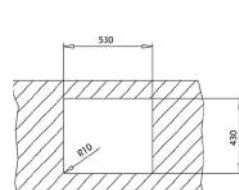
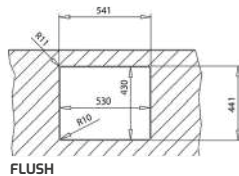
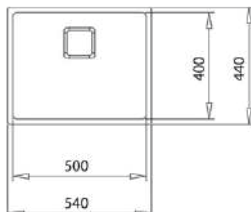

COLOR

■ Stainless Steel

PRODUCT DIMENSIONS

Sink (LxW) 540 x 440 mm
Bowl (LxWxD) 500 x 400 x 200 mm

MAESTRO BE LINEA RS15 50.40

Ref. 115000005

- PureLine stainless steel sink, One bowl
- Finish: Polished
- Undermount installation
- Easy clean radius R15 corners
- SilentSmart, 50% less noise
- 60 cm base unit
- Thickness: 1.0 mm
- Packaging: Individual carton box
(Vol: 0.1 m³ – Wt: 5.1 kg)

INCLUDED ACCESSORIES

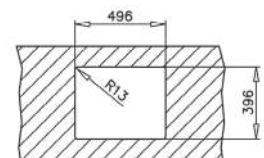
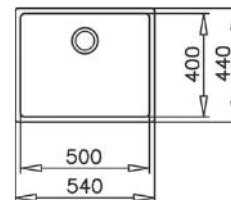

COLOR

■ Stainless Steel

PRODUCT DIMENSIONS

Sink (LxW) 540 x 440 mm
Bowl (LxWxD) 500 x 400 x 200 mm



NEW

MAESTRO PURE CLEAN FLEXLINEA RS15 40.40

Ref. 115000053

- FlexLinea Stainless steel sink, One bowl
- PureClean waterproof effect
- SofTexture finish, 3-in-1 installation: Inset/top, undermount & flush, Easy clean radius R15 corners
- Decorative SQ cover, SilentSmart, 50% less noise
- 3 1/2" SQ manual basket waste and siphon
- 50 cm base unit
- Thickness: 1.0 mm
- Packaging: Individual carton box (Vol: 0.1 m³ – Wt: 4.3 kg)

INCLUDED ACCESSORIES

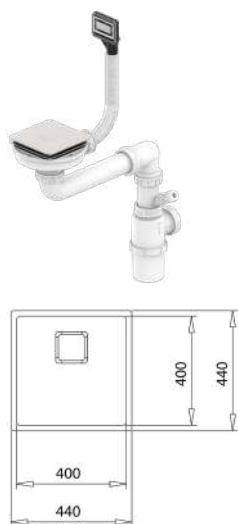

COLOR

■ Stainless Steel

PRODUCT DIMENSIONS

Sink (LxW) 504 x 514 mm
Bowl (LxWxD) 440 x 440 x 200 mm



MAESTRO FLEXLINEA RS15 40.40

Ref. 115000014

- PureLine stainless steel sink, One bowl
- Finish: Polished
- 3-in-1 installation: Inset/top, undermount & flush
- Easy clean radius R15 corners
- Decorative SQ cover
- SilentSmart, 50% less noise
- 50 cm base unit
- Thickness: 1.0 mm
- Packaging: Individual carton box (Vol: 0.1 m³ – Wt: 4.3 kg)

INCLUDED ACCESSORIES

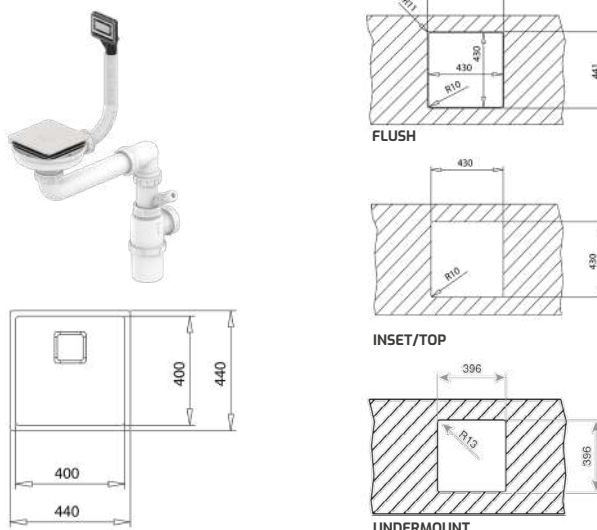

COLOR

■ Stainless Steel

PRODUCT DIMENSIONS

Sink (LxW) 440 x 440 mm
Bowl (LxWxD) 400 x 400 x 200 mm

UNDERMOUNT

SINKS



MAESTRO BE LINEA RS15 40.40

Ref. 115000007

- PureLine stainless steel sink, One bowl
- Finish: Polished
- Undermount installation
- Easy clean radius R15 corners
- SilentSmart, 50% less noise
- 50 cm base unit
- Thickness: 1.0 mm
- Packaging: Individual carton box (Vol: 0.1 m³ – Wt: 4.4 kg)

INCLUDED ACCESSORIES

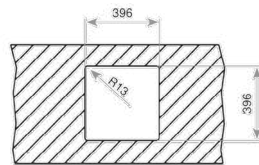
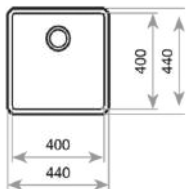

COLOR

■ Stainless Steel

PRODUCT DIMENSIONS

Sink (LxW) 440 x 440 mm
Bowl (LxWxD) 400 x 400 x 200 mm

TOTAL TU 31.19-10

Ref. 10125114

- Stainless steel sink, One bowl
- Finish: Polished
- Undermount installation
- 90 cm base unit
- Thickness: 1.0 mm
- Packaging: Individual carton box (Vol: 0.1 m³ – Wt: 6.6 kg)

INCLUDED ACCESSORIES

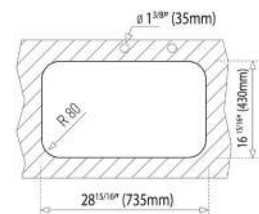
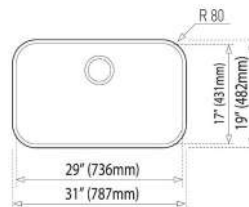

COLOR

■ Stainless Steel

PRODUCT DIMENSIONS

Sink (LxW) 787 x 482 mm
Bowl (LxWxD) 736 x 431 mm x 250 mm



TOTAL BE 40.40.25 1B

Ref. 10125021

- Stainless steel sink, One bowl
- Finish: Polished
- Undermount installation
- 50 cm base unit
- Thickness: 1.0 mm
- Packaging: Individual carton box (Vol: 0.1 m³ – Wt: 4 kg)

TOTAL BE Ø390 1B

Ref. 10125006

- Stainless steel sink, One bowl
- Finish: Polished
- Undermount installation
- 45 cm base unit
- Thickness: 0.8 mm
- Packaging: Individual carton box (Vol: 0.1 m³ – Wt: 2.3 kg)

INCLUDED ACCESSORIES

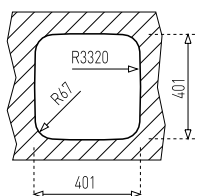
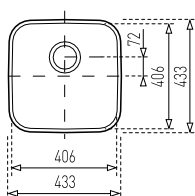

COLOR

■ Stainless Steel

PRODUCT DIMENSIONS

Sink (LxW) 435 x 435 mm
Bowl (LxWxD) 406 x 406 x 250 mm

INCLUDED ACCESSORIES

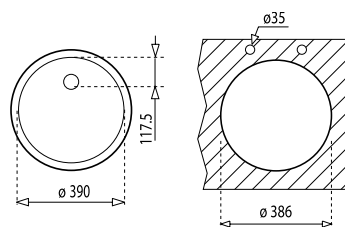

COLOR

■ Stainless Steel

PRODUCT DIMENSIONS

Sink (Ø) 390 mm
Bowl (Ø x D) 385 x 180 mm

SINKS



MAESTRO BE LINEA RS15 2B 860

Ref. 115030006

- PureLine stainless steel sink, Two bowls
- Finish: Polished
- Undermount installation
- Easy clean radius R15 corners
- SilentSmart, 50% less noise
- 90 cm base unit
- Thickness: 1.0 mm
- Packaging: Individual carton box (Vol: 0.1 m³ – Wt: 8.8 kg)

INCLUDED ACCESSORIES

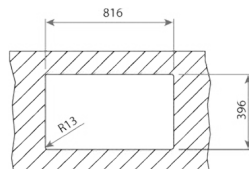
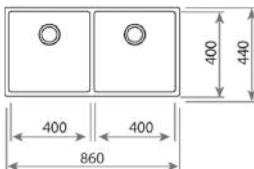

COLOR

■ Stainless Steel

PRODUCT DIMENSIONS

Sink (LxW) 860 x 440 mm
Bowl 1&2 (LxWxD) 400 x 400 x 200 mm



TOTAL BE 2B 845 R

Ref. 10125029

- Stainless steel sink, Two bowls
- Finish: Polished
- Undermount installation
- 90 cm base unit
- Thickness: 1.0 mm
- Packaging: Individual carton box (Vol: 0.1 m³ – Wt: 7.8 kg)

INCLUDED ACCESSORIES

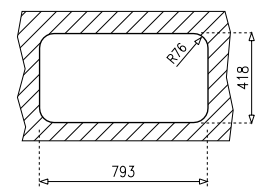
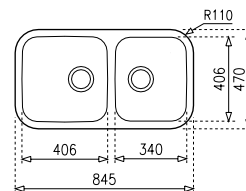

COLOR

■ Stainless Steel

PRODUCT DIMENSIONS

Sink (LxW) 845 x 470 mm
Bowl 1 (LxWxD) 406 x 406 x 180 mm
Bowl 2 (LxWxD) 340 x 406 x 180 mm



TOTAL BE 2B 780

Ref. 10125026

- Stainless steel sink, Two bowls
- Finish: Polished
- Undermount installation
- 90 cm base unit
- Thickness: 1.0 mm
- Packaging: Individual carton box
(Vol: 0.1 m³ – Wt: 6.9 kg)

INCLUDED ACCESSORIES

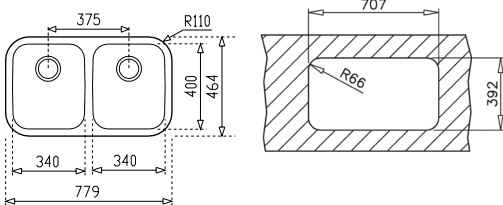

COLOR

■ **Stainless Steel**

PRODUCT DIMENSIONS

Sink (LxW) 779 x 464 mm
Bowl 1&2 (LxWxD) 340 x 400 x 200 mm





TEGRANITE



MAESTRO SQUARE 72.40 TG BK

Ref. 115230015

- Tegrinite+ sink, One bowl
- Undermount installation
- High resistance surface to impacts, thermal shocks and high temperatures
- Excellent UV resistance against decoloring
- Bacteria-free surface very easy to clean, 80% quartz and resins
- 80 cm base unit
- Thickness: 8.0 mm
- Packaging: Individual carton box (Vol: 0.2 m³ – Wt: 14.6 kg)

MAESTRO SQUARE 72.40 TG SG

Ref. 115230016

- Tegrinite+ sink, One bowl
- Undermount installation
- High resistance surface to impacts, thermal shocks and high temperatures
- Excellent UV resistance against decoloring
- Bacteria-free surface very easy to clean, 80% quartz and resins
- 80 cm base unit
- Thickness: 8.0 mm
- Packaging: Individual carton box (Vol: 0.2 m³ – Wt: 14.6 kg)

INCLUDED ACCESSORIES

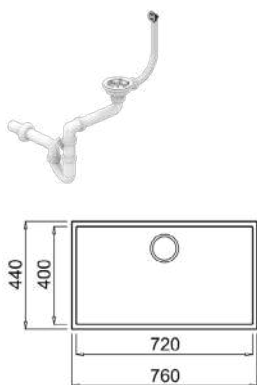

INCLUDED ACCESSORIES

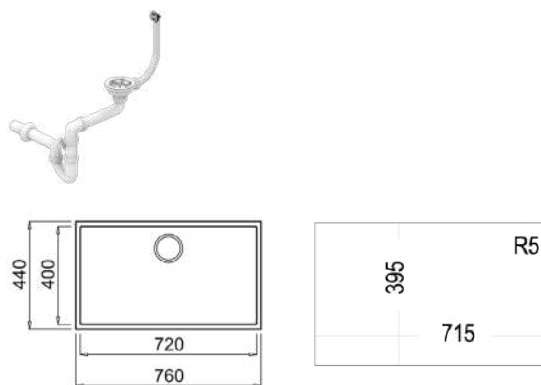

COLOR

■ Black

PRODUCT DIMENSIONS

Sink (LxW) 760 x 440 mm
Bowl (LxWxD) 720 x 400 x 200 mm

COLOR

■ Stone Grey

PRODUCT DIMENSIONS

Sink (LxW) 760 x 440 mm
Bowl (LxWxD) 720 x 400 x 200 mm

SINKS



MAESTRO SQUARE 50.40 TG BK

Ref. 115230020

- Tegrinite+ sink, One bowl
- Undermount installation
- High resistance surface to impacts, thermal shocks and high temperatures
- Excellent UV resistance against decoloring
- Bacteria-free surface very easy to clean, 80% quartz and resins
- 60 cm base unit
- Thickness: 8.0 mm
- Packaging: Individual carton box (Vol: 0.1 m³ – Wt: 10.8 kg)

MAESTRO SQUARE 50.40 TG SG

Ref. 115230021

- Tegrinite+ sink, One bowl
- Undermount installation
- High resistance surface to impacts, thermal shocks and high temperatures
- Excellent UV resistance against decoloring
- Bacteria-free surface very easy to clean, 80% quartz and resins
- 60 cm base unit
- Thickness: 8.0 mm
- Packaging: Individual carton box (Vol: 0.1 m³ – Wt: 10.8 kg)

INCLUDED ACCESSORIES

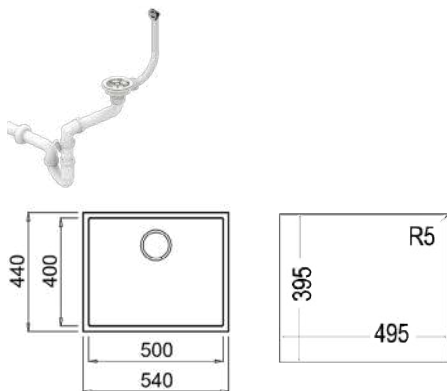

INCLUDED ACCESSORIES

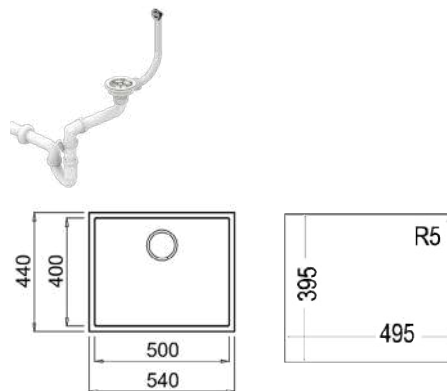

COLOR

■ Black

PRODUCT DIMENSIONS

Sink (LxW) 540 x 440 mm
Bowl (LxWxD) 500 x 400 x 200 mm

COLOR

■ Stone Grey

PRODUCT DIMENSIONS

Sink (LxW) 540 x 440 mm
Bowl (LxWxD) 500 x 400 x 200 mm



MAESTRO STONE 60 L-TG 1B 1D BC

Ref. 115330001

- Tegrinite+ sink, One bowl and one drainer
- Inset installation, Reversible drainer
- High resistance surface to impacts, thermal shocks and high temperatures
- Excellent UV resistance against decoloring
- Bacteria-free surface very easy to clean, 80% quartz and resins
- 60 cm base unit
- Thickness: 10 mm bowl / 7 mm top
- Packaging: Individual carton box (Vol: 0.2 m³ – Wt: 19.5 kg)

MAESTRO STONE 60 L-TG 1B 1D MG

Ref. 115330000

- Tegrinite+ sink, One bowl and one drainer
- Inset installation, Reversible drainer
- High resistance surface to impacts, thermal shocks and high temperatures
- Excellent UV resistance against decoloring
- Bacteria-free surface very easy to clean, 80% quartz and resins
- 60 cm base unit
- Thickness: 10 mm bowl / 7 mm top
- Packaging: Individual carton box (Vol: 0.2 m³ – Wt: 19.5 kg)

INCLUDED ACCESSORIES

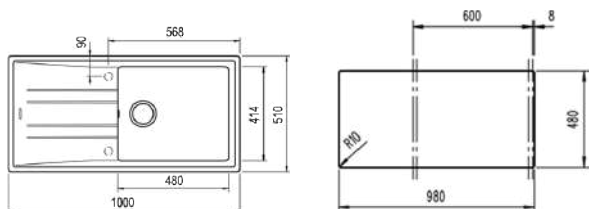

COLOR

 **Black Carbon**

PRODUCT DIMENSIONS

Sink (LxW) 1000 x 510 mm
Bowl (LxWxD) 480 x 414 x 200 mm

INCLUDED ACCESSORIES

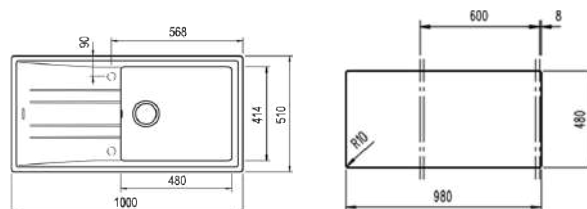

COLOR

 **Metallic Grey**

PRODUCT DIMENSIONS

Sink (LxW) 1000 x 510 mm
Bowl (LxWxD) 480 x 414 x 200 mm

SINKS



MAESTRO STONE 80 B-TG 2B 1D AUTO BC

Ref. 115400009

- Tegrante+ sink, Two bowls and one drainer
- Inset installation, Reversible drainer
- High resistance surface to impacts, thermal shocks and high temperatures
- Excellent UV resistance against decoloring
- Bacteria-free surface very easy to clean, 80% quartz and resins
- 80 cm base unit
- Thickness: 10 mm bowl / 7 mm top
- Packaging: Individual carton box (Vol: 0.2 m³ – Wt: 25.2 kg)

MAESTRO STONE 80 B-TG 2B 1D AUTO MG

Ref. 115400008

- Tegrante+ sink, Two bowls and one drainer
- Inset installation, Reversible drainer
- High resistance surface to impacts, thermal shocks and high temperatures
- Excellent UV resistance against decoloring
- Bacteria-free surface very easy to clean, 80% quartz and resins
- 80 cm base unit
- Thickness: 10 mm bowl / 7 mm top
- Packaging: Individual carton box (Vol: 0.2 m³ – Wt: 25.2 kg)

INCLUDED ACCESSORIES



INCLUDED ACCESSORIES

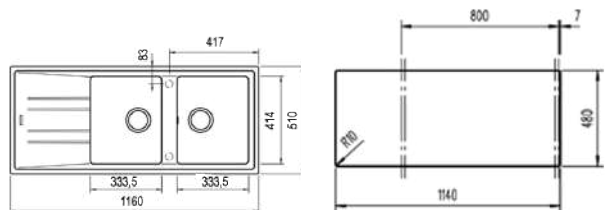
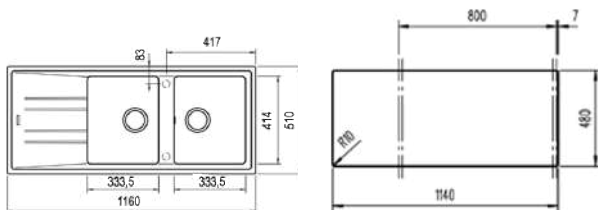

COLOR

 Black Carbon

PRODUCT DIMENSIONS

Sink (LxW) 1160 x 510 mm
Bowl 1&2 (LxWxD) 333.5 x 414 x 200 mm

COLOR

 Metallic Grey

PRODUCT DIMENSIONS

Sink (LxW) 1160 x 510 mm
Bowl 1&2 (LxWxD) 333.5 x 414 x 200 mm





TAPS

OPERA ICO 915, sleek stylish line

An exclusive, fresh and state-of-the-art design, focused on making an essential part of the kitchen, the tap, more functional. The revolutionary concept of open spout with its 5 aerators means a significant water saving, optimizing water flow.

A tap with personality to fit the style of your kitchen and to add a professional design to it, with its striking look. Nobody will remain indifferent to this tap.





TAPS



Overcome barriers

The best place to place the sink and the kitchen tap is in front of the window, if space permits. Opening or closing the window with a high spout tap ahead, is no longer a problem. Aura AUK 983, the single-lever retractable mixer tap from Teka, allows you to hide or extract your high spout whenever necessary so that nothing stumbles in your way. Thanks to its 2 positions, Aura offers maximum flexibility in the kitchen.

Teka ceramic discs

Longer taps life

All Teka cartridges use sintered ceramic discs with high resistance. These discs all have porous surfaces which retain grease longer, helping to achieve smoother, gentler movements which help to prolong the life of the taps. The operating gear is insulated from water giving therefore continuous lubrication.



Ceramic cartridge. Greater durability.



Temperature limiter

Save the energy used to heat the water with the temperature regulator that is incorporated into the cartridge.



Water saving

The cartridge incorporates an adjustable flow gauge to save water every time you use the mixer.



Anti-Scalding

Forget about scalding caused by water at high temperatures. We take care of you and your loved ones.



TAPS

* Not all taps have temperature and flow regulators in the cartridge.

KITCHEN TAPS



MAESTRO ICO 915 Brass

Ref. 116030032



- Revolutionary open spout concept
- Swivel Spout
- Anti-scale aerators integrated in the spout
- 3/8"- 1/2" Flexible inlet pipes
- High resistance (PVD Coated)

COLOR



Brass



MAESTRO ICO 915 Titanium

Ref. 116030031



- Revolutionary open spout concept
- Swivel Spout
- Anti-scale aerators integrated in the spout
- 3/8"- 1/2" Flexible inlet pipes
- High resistance (PVD Coated)

COLOR



Titanium



MAESTRO ICO 915

Ref. 116030009



- Revolutionary open spout concept
- Swivel Spout
- Anti-scale aerators integrated in the spout
- 3/8"- 1/2" Flexible inlet pipes

COLOR



Chrome



TOTAL IC 915

Ref. 339150200



- Flat design
- Swivel spout
- Cartridge with ceramic discs of high resistance
- Anti-scale aerator integrated in the spout
- 3/8" flexible inlet pipes

COLOR



Chrome



NEW

MAESTRO BKY 915

Ref. 116030056



- High spout kitchen tap, Swivel spout
- Anti-scale aerator, Waterflow limited to 5 l/min
- Cartridge with ceramic discs of high resistance
- High precise temperature control
- Easy-Quick fixation system
- 3/8" flexible inlet pipes with adaptor for 1/2"

COLOR

■ Chrome



MAESTRO FOT 999

Ref. 116010003

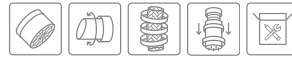

- Professional sink mixer with swivel & flexible spout
- Extra spout to fill recipients
- Hand shower with stop function, 1 function: shower
- Cartridge with ceramic discs, High resistant flexible spring
- Stainless steel flexible hose
- Easy- Quick fixation system

COLOR

■ Chrome



MAESTRO MY1

Ref. 1816002



- Swivel and flexible spout, Anti-scale aerator
- Cartridge with ceramic discs of high resistance
- Pull-down shower functions: normal & shower spray
- High resistant flexible spring
- Stainless Steel flexible hose reinforced with plastic for better protection and easy cleaning

COLOR

■ Chrome



MAESTRO FOT 939

Ref. 116010002



- Professional sink mixer with swivel & flexible spout
- Hand shower with stop function.
- Pull-down shower functions: normal & shower spray
- Cartridge with ceramic discs, High resistant flexible spring
- Stainless steel flexible hose
- Easy- Quick fixation system

COLOR

■ Chrome

KITCHEN TAPS



MAESTRO IN 934 N

Ref. 53934120N



- Swivel and flexible spout
- 35mm cartridge
- Cartridge with ceramic discs of high resistance
- Anti-scale aerator
- Certified 3/8" flexible inlet pipes

COLOR



Black



TOTAL FO 915

Ref. 629150200



- Minimalistic design
- High swivel spout
- Cartridge with ceramic discs of high resistance
- Anti-scale aerator integrated in the spout
- 3/8" flexible inlet pipes

COLOR



Chrome



MAESTRO ARK 938

Ref. 239381200



- Single lever kitchen tap
- Swivel spout
- Pull-out shower 1 function
- Anti-scale aerator
- 3/8" flexible inlet pipes

COLOR



Chrome



MAESTRO VTK 938

Ref. 249380200



- Metallic pull-out shower with 1 function
- Swivel spout
- Cartridge with ceramic discs of high resistance
- Anti-scale aerator
- 3/8" flexible inlet pipes

COLOR



Chrome



TOTAL FOT 994

Ref. 116030029



- Swivel spout
- Cartridge with ceramic discs of high resistance
- Anti-scale aerator
- 3/8" - 1/2" flexible inlet pipes
- Easy quick fixation system

COLOR

■ Chrome



TOTAL INX 915

Ref. 749150200



- Made of stainless steel of high quality AISI 304
- Swivel high spout
- Cartridge with ceramic discs of high resistance
- Anti-scale aerator
- 3/8" flexible inlet pipes

COLOR

■ Stainless Steel



EASY MTP 984

Ref. 116030000



- Under window sink mixer
- Swivel spout, Folding spout:
Max. height: 363mm, Min. height: 76mm
- Cartridge starting in cold with ceramic discs
- Anti-scale aerator, Easy-Quick fixation system
- 3/8" flexible inlet pipes

COLOR

■ Chrome



TOTAL FOT 995 Black

Ref. 116030023



- Swivel spout
- Cartridge with ceramic discs of high resistance
- Anti-scale aerator integrated in the spout
- 3/8" - 1/2" flexible inlet pipes
- Easy quick fixation system

COLOR

■ Chrome Black

KITCHEN TAPS



TOTAL FOT 995 White

Ref. 116030024



- Swivel spout
- Cartridge with ceramic discs of high resistance
- Anti-scale aerator integrated in the spout
- 3/8" - 1/2" flexible inlet pipes
- Easy quick fixation system

COLOR

Chrome White



TOTAL FOT 995

Ref. 116030022



- Swivel spout
- Cartridge with ceramic discs of high resistance
- Anti-scale aerator integrated in the spout
- 3/8" - 1/2" flexible inlet pipes
- Easy quick fixation system

COLOR

Chrome



EASY IN 995

Ref. 5399512



- Minimalistic design
- Swivel spout
- Cartridge with ceramic discs of high resistance
- Anti-scale aerator
- 3/8" flexible inlet pipes

COLOR

Chrome



EASY MN

Ref. 8191462



- Swivel spout
- Cartridge with ceramic discs of high resistance
- Anti-scale aerator
- 3/8" flexible inlet pipes

COLOR

Chrome



EASY IN 912

Ref. 5391212



- Swivel spout
- Cartridge with ceramic discs of high resistance
- Anti-scale aerator
- 3/8" flexible inlet pipes

COLOR

■ Chrome



MAESTRO MTP 978

Ref. 469781200



- Swivel Spout
- Cartridge with ceramic discs
- Pull-out shower 2 functions
- Anti-scale aerator
- 3/8" Flexible inlet pipes

COLOR

■ Chrome



EASY IN 993

Ref. 116050000



- Swivel Spout
- 40mm Cartridge with ceramic discs of high resistance
- Highly precise temperature control
- Greater handling sensitivity with smoother movements
- 3/8" flexible inlet pipes

COLOR

■ Chrome



EASY ML

Ref. 8191362



- Swivel spout
- Cartridge with ceramic discs of high resistance
- Anti-scale aerator
- 3/8" flexible inlet pipes

COLOR

■ Chrome

KITCHEN TAPS

INSTALLATION DIAGRAM

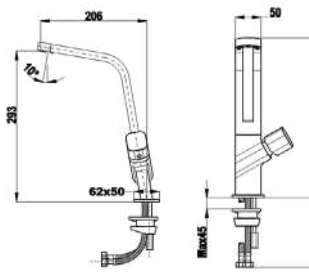

ICO 915

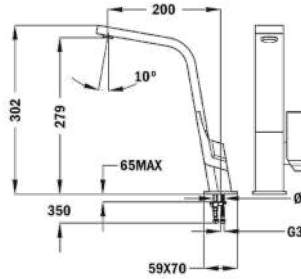

IC 915

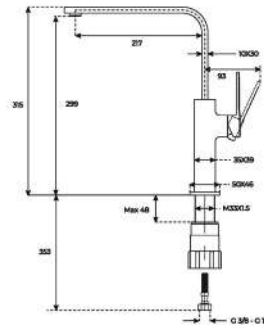

BKY 915

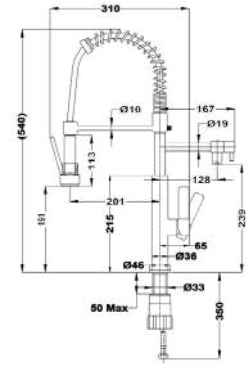

FOT 999

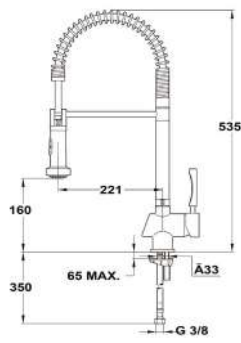

MY1

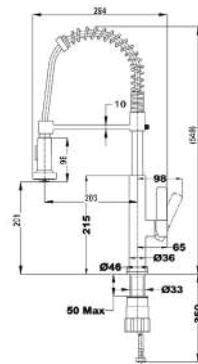

FOT 939

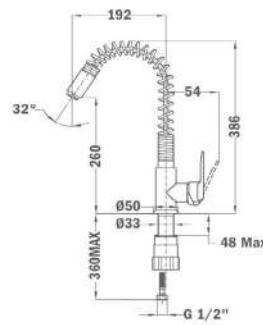

IN 934 N

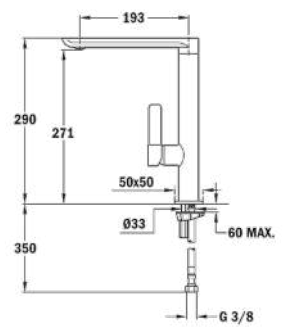

FO 915

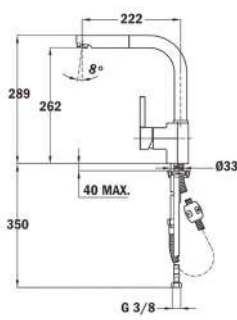

ARK 938

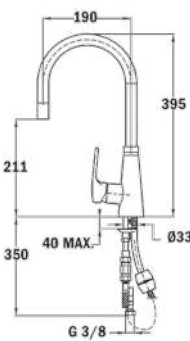

VTK 938

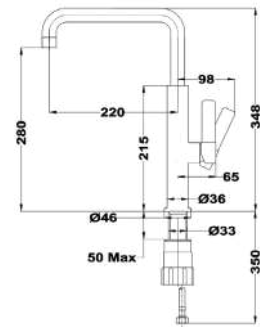

FOT 994

KITCHEN TAPS

INSTALLATION DIAGRAM

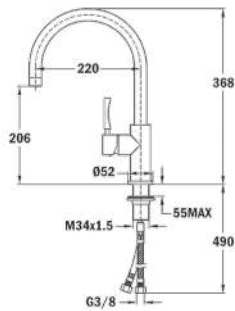

INX 915

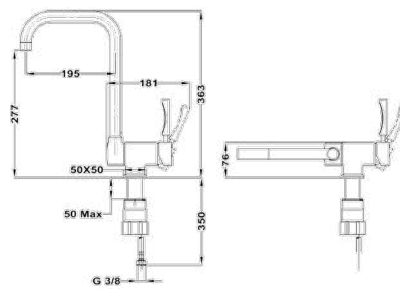

MTP 984

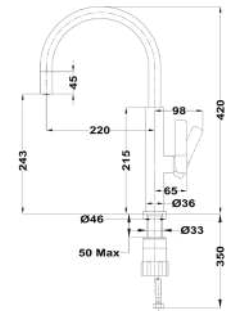

FOT 995

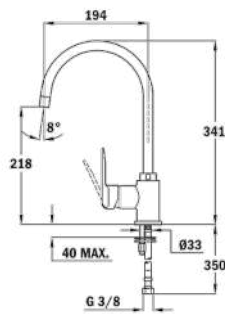

IN 995

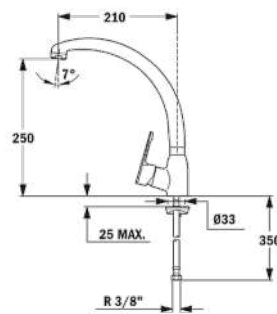

MN

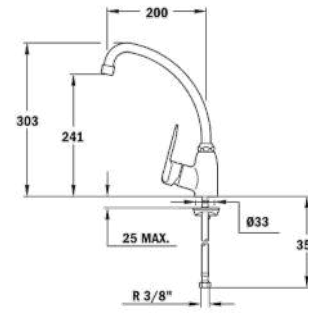

IN 912

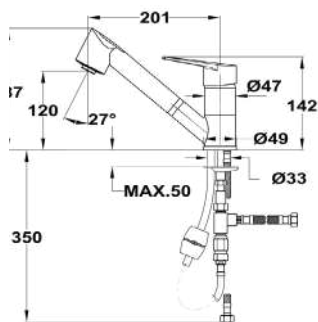

MTP 978

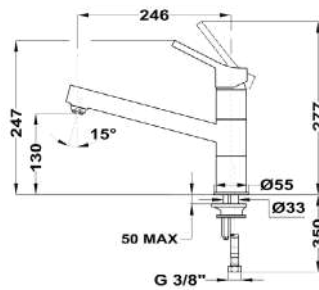

IN 993

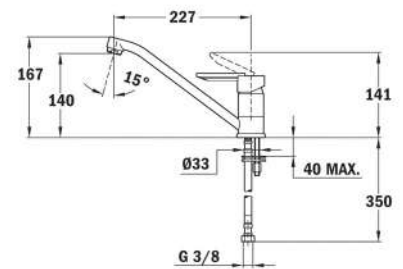

ML



The Eraser

NEW RANGE OF WASTE DISPOSERS

**Practical,
comfortable,
silent and safe**

Teka's new organic waste disposers help to keep the kitchen free of bacteria, odors, and rubbish in a comfortable and hygienic way.

It converts the waste into very fine particles that are removed through the pipes, reducing the volume of rubbish in the kitchen and the amount of plastic bags that are used.

You are one touch away from having **total hygiene** in your kitchen.

Do you have organic waste in the sink? Do you know where to throw the scraps? Get rid of all of them in just three easy steps:

1

Open the tap

2

Press the button

3

Waste is removed in a matter of seconds



Only **benefits**

- ▶ **Greater hygiene** in your kitchen.
- ▶ **Sustainability:** reduces the accumulated rubbish as well as the use of bags.
- ▶ **Safety:** Teka's waste disposals do not use blades or fans for operation.
- ▶ The disposers are very **quiet**, thanks to their high-torque **Dura-Drive®** induction motor and their new grinding technology.
- ▶ They do not need maintenance.
- ▶ Their consumption of water and energy is **minimal**.



TR 550

Ref: 115890013

- Waste grinder
- Stainless steel, corrosion protection
- Power 0.55 hp (380 W)
- Weight: 14.5 kg
- Dimensions: 173 x 318 mm
- Equipment included: externally mounted pneumatic switch

COLOR

■ Stainless Steel

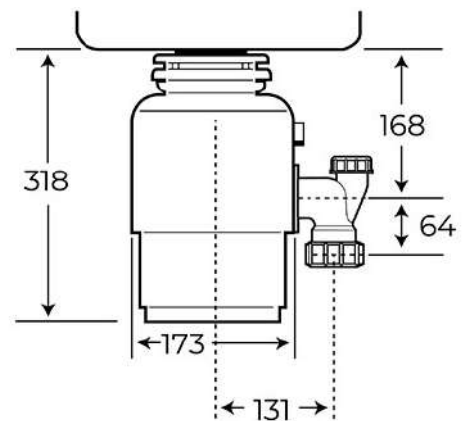

SINK ACCESSORIES



DISH BASKET
370X315X145 S/ST

Ref: 40199037



S. STEEL COLANDER
(420 X 200 X 74) R15

Ref: 40199072



BAMBOO CUTTING BOARD

Ref: 40199236



UNIVERSAL FOLDABLE
COLANDER

Ref: 115890024



SOAP DISPENSER SQUARE
PS111-BN INOX

Ref: 115890012



BASKET VALVE DECORATIVE
LID

Ref: 40199510



WASTES AND CONNECTION KITS



KIT MAN. WASTE **HELIXPRO**
1B W/OVF RND SP

Ref: 61001403



KIT MAN. WASTE **HELIXPRO**
1 1/2 B W/WO/OVF RND SP

Ref: 61001404

HELIXPRO
Exclusive strainer
design by Teka

More **ergonomic** and functional with an avant-garde **design**. An efficient basket designed to facilitate faster and more **hygienic** evacuation of liquids.



BASKET WASTE **HELIXPRO**
1B WO/OVF

Ref: 61001401



BASKET WASTE SET **HELIXPRO**
1 1/2 B/2B W/WO/OVF RND

Ref: 61001402



BASKET WASTE **HELIXPRO**
1B W/OVF RND

Ref: 61001400





WASTE KIT 1B MANUAL VALVE ASSY. **SQUARE** DRAINAGE +1 COVER

Ref: 61001278



WASTE KIT 1B MANUAL VALVE ASSY. **SQUARE** DRAINAGE +1 COVER MICROTEXTURE

Ref: 61001290

FLEXLINEA

Suitable for square fittings. Top line **design** with straight lines and maximum **efficiency**.



KIT MAN. WASTE TEKA 1B W/OVF RND SP

Ref: 61001293



KIT MAN. WASTE TEKA 1^{1/2}/2B W/WO/OVF RND SP

Ref: 61001294

New concept

SPACE SAVER

Set of **connections** for sinks with 1 Bowl and 2 Bowls to **optimize and provide free space** under the sink.



WASTES AND CONNECTION KITS



FITTINGS FOR 2B: CONNECTION, SIPHON, PIPE TO WALL + DECORATIVE END CAP

Ref: 61001314



FITTINGS FOR 1^{1/2} & 2B (DIFFERENT HEIGHTS): CONNECTION, SIPHON, PIPE TO WALL + DECORATIVE END CAP

Ref: 61001315

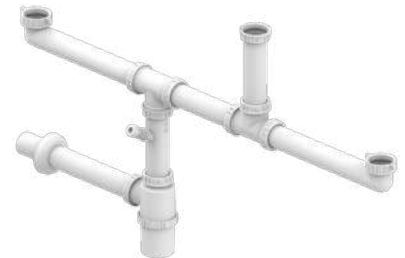

FITTINGS FOR 2^{1/2}B: CONNECTION, SIPHON, PIPE TO WALL + DECORATIVE END CAP

Ref: 61001316

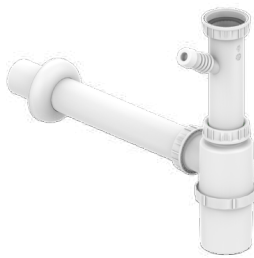

FITTINGS FOR 1B: SIPHON, PIPE TO WALL + DECORATIVE END CAP

Ref: 61001313



1^{1/2} WASTE WITH OVERFLOW

Ref: 61001300



1^{1/2} WASTE WITHOUT OVERFLOW

Ref: 61001301



3^{1/2} BASKET WASTE WO/OVERFLOW S/ST

Ref: 61001303



3^{1/2} BASKET WASTE SET W/WO/OVF

Ref: 61001305



3^{1/2} BASKET WASTE W/OVERFLOW S/ST

Ref: 61001302

