



**ARK 915 Mixer**



Anti-scale  
aerator



Swivel spout

**DESCRIPTION**

Mixer

**LIFE STYLE**

Easy

**COLOURS**



**REFERENCE**

REF. 239151210  
EAN. 8421152084700



## ARK 915

### FEATURES

Mixer  
Swivel spout 3/8" flexible inlet pipes  
Anti-scale aerator



**ARK 915**

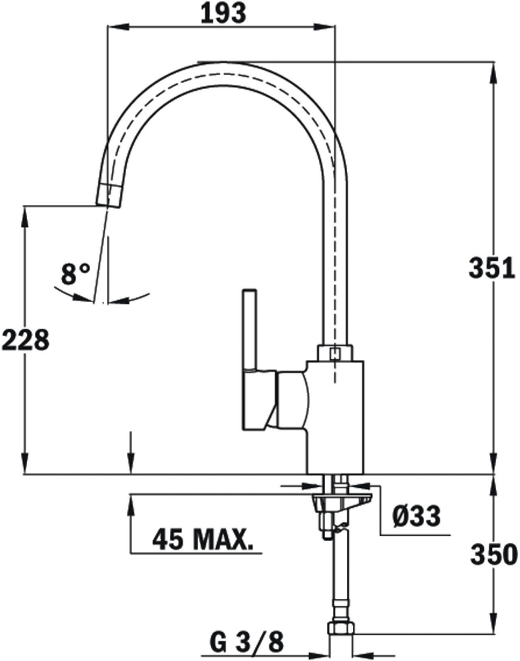

**DIMENSIONS**

- Product height (mm): 351
- Product width (mm):
- Product depth (mm):
- Product length (mm):
- Net weight (Kg): 1,7

**TECH SPECS**

**MODELS**

**Type of installation:** Free standing

