



EWH 50 D SLIM Slim Water heater with double installation system and 50L capacity



Dry Heating Protection



ELCB Earth Leakage Circuit Breaker



Humidity Control



Overheating Protection



Slim heater



Type of Installation

DESCRIPTION

Slim Water heater with double installation system and 50L capacity

COLOURS



REFERENCE

REF. 42080060
EAN. 8421152156834



TEKA

EWH 50 D SLIM

FEATURES

Slim shape
Vertical and horizontal installation
Capacity: 47 litres
Average number of users: 2-3
Tank ultra-resistant protective polish
Enamelled heating element
Temperature regulation 30° - 75° C
Max input pressure: 0.75 Mpa
Over-pressure protection
Over-heating protection
Humidity protection
Dry-heating protection
Earth leakage circuit breaker ELCB
Power rate: 2000 W
Isolation thickness: 18 mm
Power levels: 2

TEKA

EWH 50 D SLIM

DIMENSIONS

Product height (mm): 860
Product width (mm): 470
Product depth (mm): 250
Product length (mm):
Net weight (Kg): 25,81

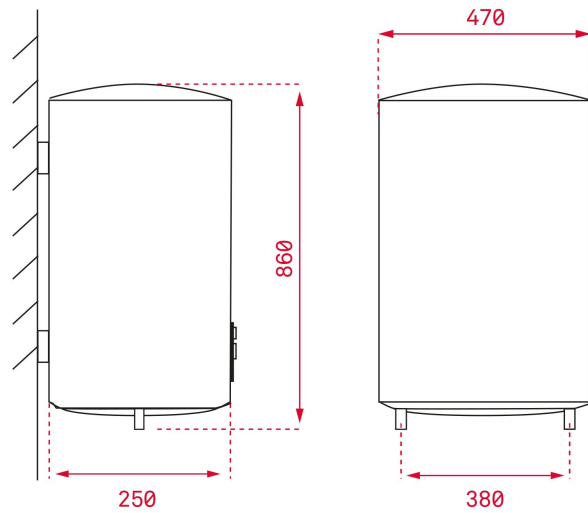

TECHNICAL DETAILS

ELECTRIC CONNECTION

Frequency (Hz): 50
Power rate (V): 220
Plug type: EU

ENERGY EFFICIENCY

Energy Efficiency Class: B

MODELS

Control panel: ELECTRONIC



EWH 50 D SLIM

ENERGY LABEL

