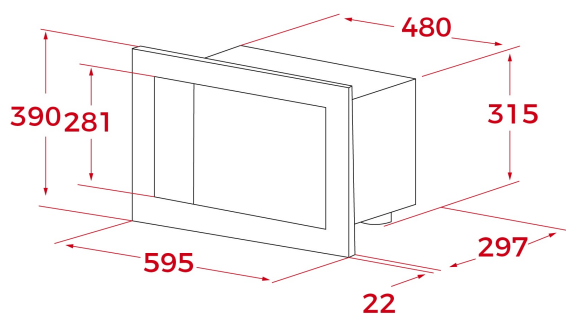

TEKA**ML 820 BI**
20L Built-in Mechanical MicrowaveDefrost By
Time**REFERENCE**

REF: 40584201 EAN: 8421152145562

FEATURES

Microwave
Capacity: 20 litres
Electromechanical controls
5 power levels, 700 W
1 cooking function
Automatic defrosting by time
Double glazed door
Stainless steel inner cavity

DIMENSIONS**Product height (mm):** 390**Product width (mm):** 595**Product depth (mm):** 325**Product length (mm):****Net weight (Kg):** 17,5**TECHNICAL DETAILS**

MWO Power (W): 750

Frequency (Hz): 50

Maximum Nominal Power (W): 1200

Grill (W): -

COLOURS

40584201 Black Glass with StainlessSteel frame