

TKI3 150 EU

Built-in refrigerator with inverter motor and antibacterial gasket

**REFERENCE**

REF: 113470005

EAN: 8434778014372

FEATURES

Built-in top freezer refrigerator
 Manual defrost
 Manual adjustable thermostat
 FreshBox drawers
 3 safety glass shelves
 Front adjustable feet
 LED illumination
 Reversible doors
 Climate class: SN/T
 Total capacity (gross/net): 135 / 126 litres

Motor
Inverter

Easy 90



Fresh Box

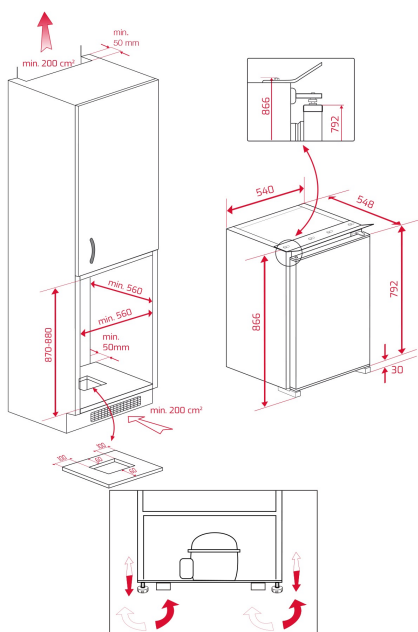

LED

**DIMENSIONS****Product height (mm):** 866**Product width (mm):** 545**Product depth (mm):** 545**Product length (mm):****Net weight (Kg):** 30,5**TECHNICAL DETAILS**

Energy efficiency class (UE 2019/2016): A++

Climate Class: SN/T

Energy Consumption (Kw/day): 0,258

Annual Consumption (kWh/year): 94

Freezing Capacity: NA

Noise Level (dBA): 35

Power rate (V): 230

Frequency (Hz): 50

COLOURS