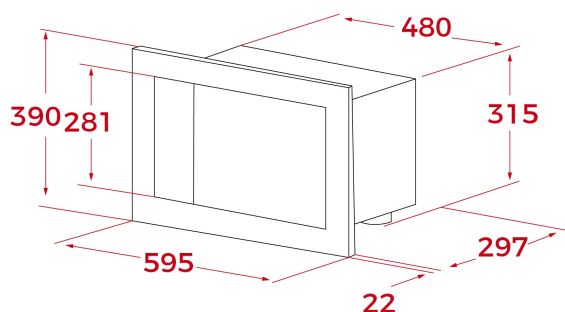

TEKA**ML 820 BI BK-SS**

Built-in mechanical microwave with automatic defrosting mode

Defrost By
Time**REFERENCE**

REF: 40584201

EAN: 8421152145562

FEATURES

Built-in Microwave
1 cooking function
5 power levels, 1200 W
Defrost by time
Mechanical control knobs
Double glazed door with right opening
Automatic disconnection when open door
Capacity (gross/net): 18 / 20 litres
Stainless steel cavity

DIMENSIONS**Product height (mm):** 390**Product width (mm):** 595**Product depth (mm):** 325**Product length (mm):****Net weight (Kg):** 17,5**TECHNICAL DETAILS**

MWO Power (W): 750

Frequency (Hz): 50

Maximum Nominal Power (W): 1200

Grill (W): -

COLOURS

40584201

Black glass with frame