



CNL 6415 60cm Pull-out Hood with ECOPOWER motor and and 2+1 speeds



LED



Stop Delay
Timer

DESCRIPTION

60cm Pull-out Hood with ECOPOWER motor and and 2+1 speeds

LIFE STYLE

Total

COLOURS

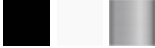

REFERENCE

REF. 40436812
EAN. 8421152146194

FEATURES

Pull-out hood
EcoPower motor
Energy Efficiency class: A
Electronic control panel
5+1 speeds
Exhaust capacities:
Free Outlet, m³/h: 393
Qboost, m³/h: 385
Max., m³/h: 293
Min., m³/h: 141
Noise (LwA) Boost Speed, dB: 69
Noise (LwA) Max Speed, dB: 63,9
Noise (LwA) Min Speed, dB: 51,6
1 LED bar
2 stainless Steel filters MMX
Reinforced Black Glass upper structure
Automatic Lighting
Exchangeable Front Panel

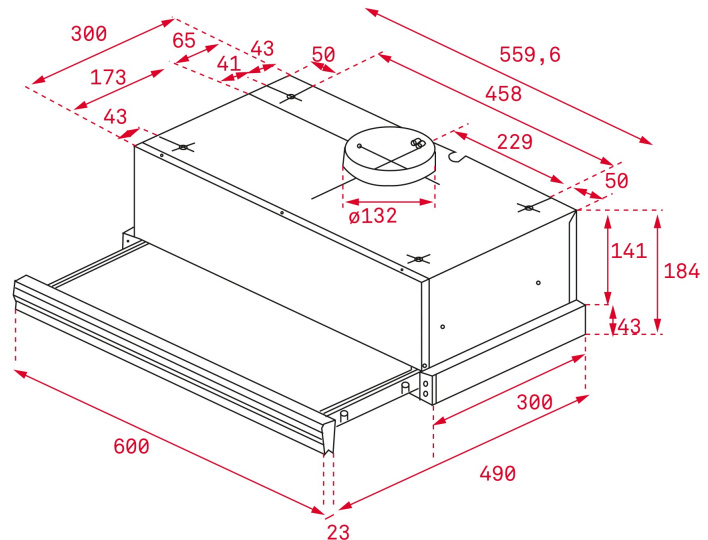

DIMENSIONS

Product height (mm): 184

Product width (mm): 600

Product depth (mm): 300/490

Product length (mm):

Net weight (Kg): 7,10

TECH SPECS

PARTICULAR CHARACTERISTICS

Type of hood: Pull-out

Style: Integrated

Certificates: CE; CB; Rohs

Ø Outlet (mm): 120

Type of inner light: LED

Inside light Consumption (W): 1,5

Plug type: European plug

Power rate (V): 230

Frequency (Hz): 50

Total hood power (W): 113

Number of motors: 1

Motor power (W): 110

Exhaust Capacity - Free Outlet (m³/h): 393

**EU REGULATION NO. 65/2014
&66/2104**

Annual energy consumption AEC kWh/annum (kWh): 25,9

Energy Efficiency Class: A

Fluid Dynamic Efficiency (FDEhood): 26,7

Fluid Dynamic Efficiency class: B

Light Efficiency (Lehood) lux/Watt: 42,7

Lighting Efficiency class: A

Grease Filtering Efficiency class: D
Air flow (Qmin) m3/h: 226
Air flow (Qmax): 312
Air flow (Qboost): 385
Noise (LwA) Min Speed (dB): 57
Noise (LwA) Max Speed (dB): 64
Noise (LwA) boost speed (dB): 69
Energy Efficiency Index (EEI): 49,1
Time increase factor: 1,0
Electric power input at best efficiency point (Wbep) W: 65,0
Nominal power of the lighting system (WL) W: 3
Average illumination of the lighting system on the cooking surface (Emiddle) Lux: 128

ACCESSORIES

Anti Return valve: Yes
Optional Charcoal Filter: CNL 1C
Charcoal filter description: CHARCOAL FILTER CNL 1C

MODELS

Number of filters: 2
Filter description: Stainless Steel filters
Control panel: Electronic
Stop delay timer: Yes
Automatic lighting: Yes
Number of speeds: 2+1

PRODUCT INFORMATION SHEET - DELEGATED REGULATION (EU) 65/2014

Supplier name or trademark: TEKA
Model identifier: CNL 6415
Annual Energy Consumption: 25,9
Energy Efficiency Class: A
Fluid Dynamic Efficiency: 26,7
Fluid Dynamic Efficiency class: B
Lighting Efficiency: 42,7
Lighting Efficiency class: A
Grease Filtering Efficiency class: D
Air flow (min speed normal use): 226
Air flow (max speed normal use): 312
Air flow (intensive or boost use): 385
Airborne acoustical A-weighted sound power emissions (min speed normal use): 57
Airborne acoustical A-weighted sound power emissions (intensive or boost use): 69
Power consumption in off mode (W): n.a
Power consumption in standby mode (W): n.a



CNL 6415

ENERGY LABEL

