



WMT 70945 PremiumCare Series Free Standing Washing Machine with 15 washing programs



Quick Cycle

DESCRIPTION

PremiumCare Series Free Standing Washing Machine with 15 washing programs

LIFE STYLE

Maestro

COLOURS



REFERENCE

REF. 113900005
EAN. 8434778016628

FEATURES

PremiumCare series
Free standing Washing Machine
Inverter motor
Electronic control panel with display
Washing capacity: 9 kg
15 washing programs
Fast program: 12 minutes
Special programs: ECO mode, Wool care, Delicate, Anti-allergies mode
Special functions: Delay timer, Speed wash, Steam, Anti-allergies, Stain type, Extra rinse
SmartWash system
Maximum spinning speed: 1400 RPM
Automatic water regulation
Automatic door lock safety system
Child lock
Balance control system
SoftCare drum
Delay timer: 1-24 hours
33 cm wide porthole door

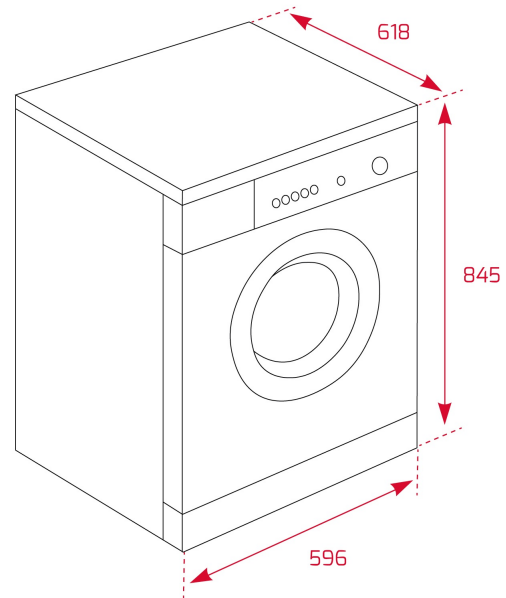

DIMENSIONS

Product height (mm): 845
Product width (mm): 596
Product depth (mm): 618
Product length (mm):
Net weight (Kg): 75

TECH SPECS

PRODUCT SHEET

Type of installation: Free standing
Energy consumption (kWh/year): 151
Water consumption (litres/year): 12100

POWER SUPPLY

Frequency (Hz): 50
Power rate (V): 220-240
Plug type: EU
Cable Connection Length (cm): 1,6
Maximum Nominal Power (W): 2200
Nominal power motor (W): No
Power of heating element (W): 1850
Water outlet hose length (m): 1.615
Water inlet hose length (m): 1470

PARTICULAR CHARACTERISTICS

Stainless Steel Drum: Yes
Glass door diameter (cms): 47
Number of programs: 15
Number Of Washing Temperatures: 8
Control panel: ELECTRONIC

CONTROL INDICATOR LIGHTS

SPECIAL FUNCTIONS

EQUIPMENT

Electronic washing management: Yes

Child lock: Yes

Auto lock door: Yes

Cancel spin cycle button: Yes

Removable work top: Yes

Selected program indicator: Yes

Remaining time: Yes

Fast program: Yes

Fast program (minutes): 12

Economic program: Yes

Delicate fabrics: Yes

Adjustable Feet Back: Yes

Adjustable feet front: Yes



WMT 70945

ENERGY LABEL

