



SMART EWH 100 VE-D Smart Control water heater with temperature LED indicator and 100L capacity



Dry Heating Protection



Electronic Smart Control



Humidity Control



Overheating Protection

DESCRIPTION

Smart Control water heater with temperature LED indicator and 100L capacity

LIFE STYLE

Maestro

COLOURS



REFERENCE

REF. 42080340
EAN. 8421152149256

FEATURES

Smart series: Habits-based adapting system
Vertical installation
Capacity: 100 litres
Average number of users: 3-5
Tank ultra-resistant protective polish
Enamelled heating element
Temperature regulation 30° - 75° C
Max input pressure: 0.75 Mpa
Over-pressure protection
Over-heating protection
Humidity protection
Dry-heating protection
Power rate: 1500 W
Isolation thickness: 20 mm

DIMENSIONS

Product height (mm): 956
Product width (mm): 450
Product depth (mm): 450
Product length (mm):
Net weight (Kg): 29,26

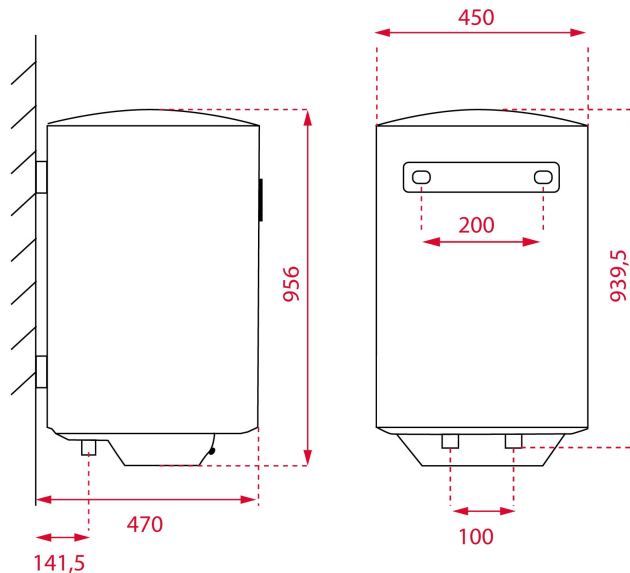

TECH SPECS

PARTICULAR CHARACTERISTICS

Power rate (V): 220-240
Frequency (Hz): 50/60
Power rate (W): 1.500
Plug type: EU
Type of installation: Vertical
Certificates: CE
Average number of users: 3-5
Control panel: ELECTRONIC
Number of power levels: 1
Maximum input pressure (Mpa): 0,75
Sapphire Enamelled Steel Tank: Yes
Magnesium protection anode: Yes
Heating element indicator lamp: Yes
Insulation thickness (mm): 20,00
Degree of protection against humidity: IPX4
Protection against heating: Yes
Dry heating protection: Yes

EU REGULATION NO.
812/2013

Declared load profile: M
Water heating energy efficiency class: B
Annual energy consumption AEC kWh/annum (kWh): 1161,00
Sound power level L WA (dB): 15

**EU REGULATION NO.
814/2013**

Storage Volume V L (L): 100



SMART EWH 100 VE-D

ENERGY LABEL

