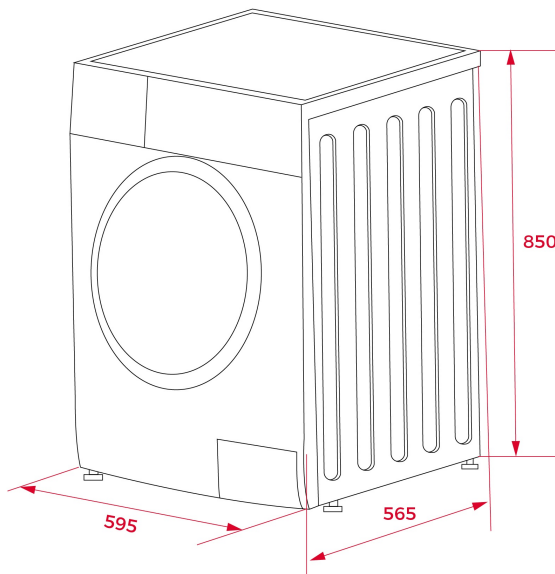

TEKA**AutoDose WMK 81050 WH**

Quick
cycle
program

**REFERENCE**

REF: 113900015

EAN: 8434778028478

FEATURES

Free standing washing machine
AutoDose system
Inverter Motor
Electronic control panel with display
Washing capacity: 10 kg
14 washing programs
Special programs: Fast program: 15 minutes, ECO mode program, wool care program, sport program
Special functions: Delay timer function, speed wash function, steam function, extra rinse function
SmartWash system
Maximum spinning speed: 1500 RPM
Automatic water regulation
Automatic door lock safety system
Child lock
Balance control system
48 cm wide porthole door

DIMENSIONS**Product height (mm):** 850**Product width (mm):** 595**Product depth (mm):** 630**Product length (mm):****Net weight (Kg):** 72**TECH SPECS**

Energy efficiency class (UE 2019/2016): A

Washing performance Class: /

Spinning efficiency class: B

Water consumption (litres/year): /

Noise Level (dBA): 0 + 80

Power rate (V): 220-240 V~

Frequency (Hz): 50 Hz

COLORS

113900015 White