

TEKA

SHK 81030 WH

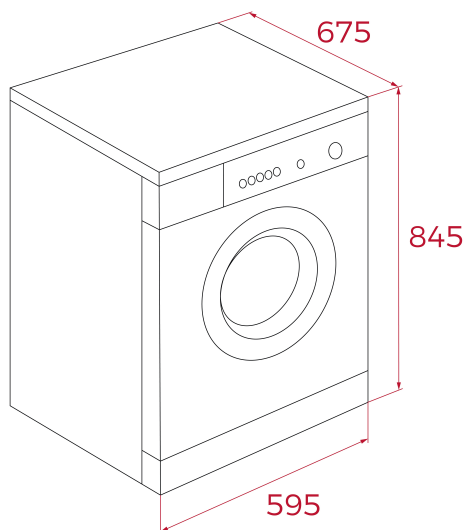

REFERENCE

REF: 114060006

EAN: 8434778031829

FEATURES

Free standing dryer
Condensed heat pump drying technology
Electronic control panel with display
Drying capacity: 10 kg
Drying programs: 14
ECO mode program
Wool care program
Baby Care program
Refresh program
Delay timer function
Delicate program
Drying level function
Hygiene function
SoftCare drum
Child lock

DIMENSIONS

Product height (mm): 845

Product width (mm): 595

Product depth (mm): 675

Product length (mm):

Net weight (Kg): 48

TECH SPECS

Energy Efficiency Class: C

Energy Consumption (Kw/day): -

Drying Efficiency Class: B

Noise level drying (dB): 65

Power rate (V): 220-240

Frequency (Hz): 50Hz

COLORS

114060006 White