

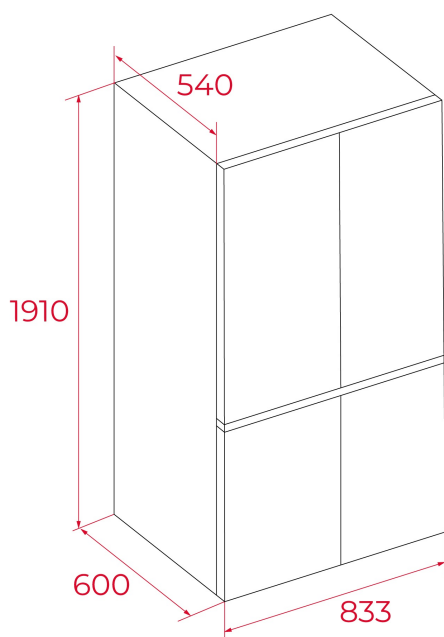

High efficiency
Inverter
Motor



LED
lighting



REFERENCE

REF: 113430087

EAN: 8434778038736

FEATURES

In-Line Series
Slot-in Cross door refrigerator
Antiox Zone
BioPure Zone
1 FreshBox drawer
6 UltraFreeze Box -30°C
IonGuard Technology
GlassCooling
Total No Frost
Inverter motor
Electronic adjustment thermostat
3 safety shelves with metallic finish
6 door balconies with metallic finish
LED Illumination
Fast freezing and fast cooling function
Key lock indicator
Acoustic alarm
Climate class: SN/N/ST/T
Total capacity (net): 514 litres
Energy Class: E

DIMENSIONS

Product height (mm): 1910

Product width (mm): 833

Product depth (mm): 600

Product length (mm):

Net weight (Kg): 133

TECH SPECS

Energy efficiency class (UE 2019/2016): -

Climate Class: SN/N/ST/T

Energy Consumption (Kw/day): 0.845

Annual Consumption (kWh/year): 310

Freezing Capacity: 12

Noise Level (dBA): 37C

Power rate (V): 220-240

Frequency (Hz): 50

COLORS



113430087

Stone Grey