



DLH 985 T 90cm Decorative Hood with Touch Control Display and ECOPOWER A4 motor



LED lighting



Full A 4 energy label: A class in energy efficiency, fluid dynamic, lightning and grease filtering.



Stop delay timer

DESCRIPTION

90cm Decorative Hood with Touch Control Display and ECOPOWER A4 motor

LIFE STYLE

Maestro

COLORS



REFERENCE

REF. 40437100
EAN. 8421152145661

FEATURES

Ultraslim decorative hood
EcoPower motor
Energy Efficiency class: A
4A (Energy efficiency A, Fluid dynamic efficiency A, lighting efficiency A, grease filtering efficiency A)
Touch control panel
Operating Pilot Light
3 speeds + 1 intensive
Exhaust capacities:
Free Outlet, m³/h: 795
Qboost, m³/h: 740
Max., m³/h: 586
Min., m³/h: 306
Noise (LwA) Boost Speed, dB: 72
Noise (LwA) Max Speed, dB: 68
Noise (LwA) Min Speed, dB: 54
1 LED BAR
3 stainless steel filters (12 layers)
Stop delay timer
Filter saturation indicator

DIMENSIONS

Product height (mm): 670-1000
Product width (mm): 900
Product depth (mm): 480
Product length (mm):
Net weight (Kg): 15,33

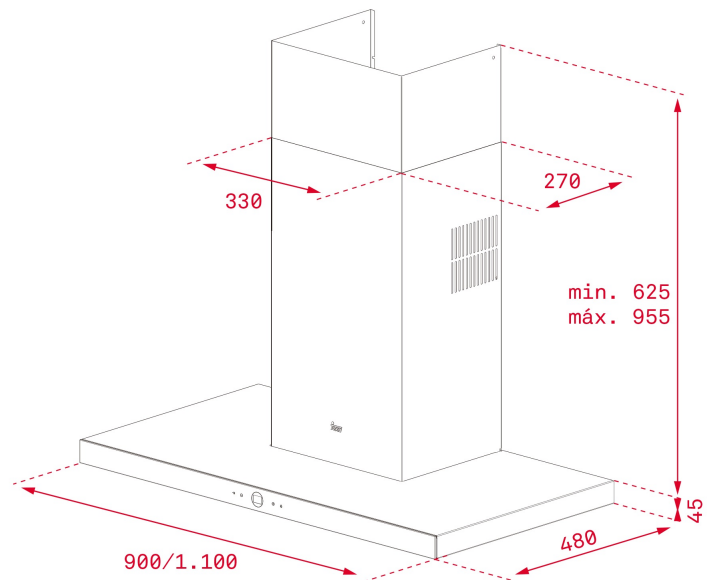

TECH SPECS

PARTICULAR CHARACTERISTICS

Type of hood: Horizontal
Style: Decoratives
Certificates: CE; CB; Rohs
Ø Outlet (mm): 150
Inside light Consumption (W): 1,7
Plug type: Schuko plug
Power rate (V): 230
Frequency (Hz): 50
Total hood power (W): 287
Number of motors: 1
Motor power (W): 280
Exhaust Capacity - Free Outlet (m³/h): 795

**EU REGULATION NO. 65/2014
&66/2104**

Annual energy consumption AEC kWh/annum (kWh): 41,0
Energy Efficiency Class: A
Fluid Dynamic Efficiency (FDEhood): 34,3
Fluid Dynamic Efficiency class: A
Light Efficiency (Lehood) lux/Watt: 55,7
Lighting Efficiency class: A
Grease Filtering Efficiency class: A

Air flow (Qmin) m³/h: 352
Air flow (Qmax): 651
Air flow (Qboost): 760
Noise (LwA) Min Speed (dB): 54
Noise (LwA) Max Speed (dB): 68
Noise (LwA) boost speed (dB): 72
Off mode Power (Po) W: 0,32
Energy Efficiency Index (EEI): 47,2
Time increase factor: 0,8
Electric power input at best efficiency point (Wbep) W: 123,0
Nominal power of the lighting system (WL) W: 7
Average illumination of the lighting system on the cooking surface (Emiddle) Lux: 390

ACCESSORIES

Anti Return valve: Yes
Outlet reduction: Yes
Conventional recirculation kit (with tube cover): 40490147

MODELS

Number of filters: 3
Stop delay timer: Yes
Filter saturation indicator: Yes
Time clock: Yes
Number of speeds: 3+1



DLH 985 T

ENERGY LABEL

