



DH2 90.1 AD 90cm Island Hood With Electronic Control Panel



DESCRIPTION

90cm Island Hood With Electronic Control Panel

LIFE STYLE

Maestro

COLORS



REFERENCE

REF. 40491920
EAN. 8421152145050



TEKA

DH2 90.1 AD

FEATURES

Island Hood
Electronic Control Panel
3 Speeds With 2 LED Lamps (1.5W)
Exhaust Capacity: 1,500M³/H
Sound Power Level: 65dBA
Metal Filters
Conventional Extraction
Optional Recirculating Or Ducting System
Kraftvoll Technology



DH2 90.1 AD

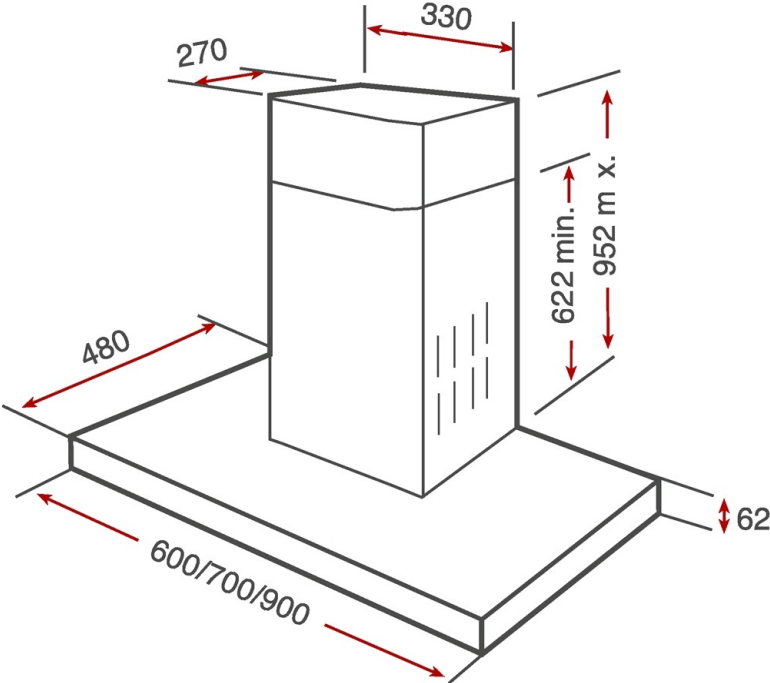

DIMENSIONS

- Product height (mm):
- Product width (mm):
- Product depth (mm):
- Product length (mm):
- Net weight (Kg):

TECH SPECS

PARTICULAR CHARACTERISITICS

Type of hood: Island
Style: Decoratives

