



DPL Island 1185 110cm Island Hood with Contour Rim extraction, Touch control and ECOPOWER motor



LED



Perimeter extraction



Stop Delay Timer

DESCRIPTION

110cm Island Hood with Contour Rim extraction, Touch control and ECOPOWER motor

LIFE STYLE

Maestro

COLOURS



REFERENCE

REF. 40483172
EAN. 8421152145777

FEATURES

Decorative horizontal island hood
Electronic control with display
Rim extraction
EcoPower motor
3 speeds + 1 intensive
Free Outlet exhaust capacity (m³/h): 920
Intensive speed exhaust capacity (m³/h): 782
Max speed exhaust capacity (m³/h): 629
Min speed exhaust capacity (m³/h): 331
Intensive speed sound level (dBA): 69
Max speed sound level (dBA): 66
Min speed sound level (dBA): 54
4 LED lamps
3 aluminium filters
Stop delay timer
Filter saturation indicator
Operating pilot light
Anti-return valve included
Outlet reduction included
Optional recirculation kit with tube cover installation: SET 1/T1
Optional Charcoal Filter: D4C

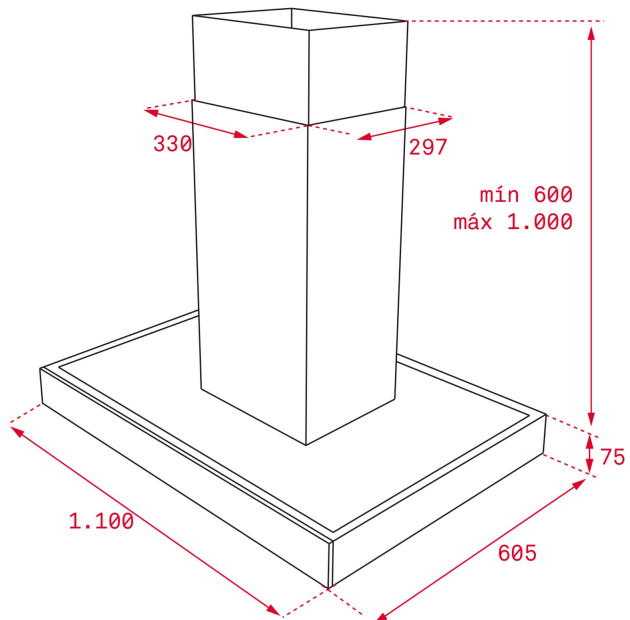

DIMENSIONS

Product height (mm): 817-1117

Product width (mm): 1100

Product depth (mm): 605

Product length (mm):

Net weight (Kg): 17,4

TECH SPECS

PARTICULAR CHARACTERISTICS

Ø Outlet (mm): 150
Type of inner light: LED
Inside light Consumption (W): 3
Plug type: European plug
Power rate (V): 220240
Frequency (Hz): 50
Total hood power (W): 292
Number of motors: 1
Motor power (W): 280
Air flow (Qmin) m³/h: 331
Air flow (Qmax): 629
Air flow (Qboost): 782

ACCESSORIES

Anti Return valve: Yes
Outlet reduction: Yes
Optional Charcoal Filter: D4C
Conventional recirculation kit (opt) - w/tube cover: SET 1/T1

MODELS

Number of filters: 3

Filter description: inox panel; aluminum filters below

Control panel: Touch control

Stop delay timer: Yes

Filter saturation indicator: Yes

Number of speeds: 3+1



DPL Island 1185

ENERGY LABEL

