



CC 485 ISLAND 40cm Tubular Island Hood Design With Touch Control And ECOPOWER Motor



LED lighting



Stop delay timer

DESCRIPTION

40cm Tubular Island Hood Design With Touch Control And ECOPOWER Motor

LIFE STYLE

Maestro

COLORS



REFERENCE

REF. 40480330
EAN. 8421152145869

FEATURES

Tubular Island Hood
ECOPOWER Motor
Energy Efficiency Class: A
Touch Control Panel
White Digital Display
3 Speeds + 1 Intensive
Exhaust Capacities:
Free Outlet, M³/H: 920
Qboost, M³/H: 771
Max., M³/H: 525
Min., M³/H: 305
Noise (Lwa) Boost Speed, db: 78
Noise (Lwa) Max Speed, db: 72
Noise (Lwa) Min Speed, db: 50
2 LED Lamps
1 Stainless Steel Filter
Stop Delay Timer
Filter Saturation Indicator

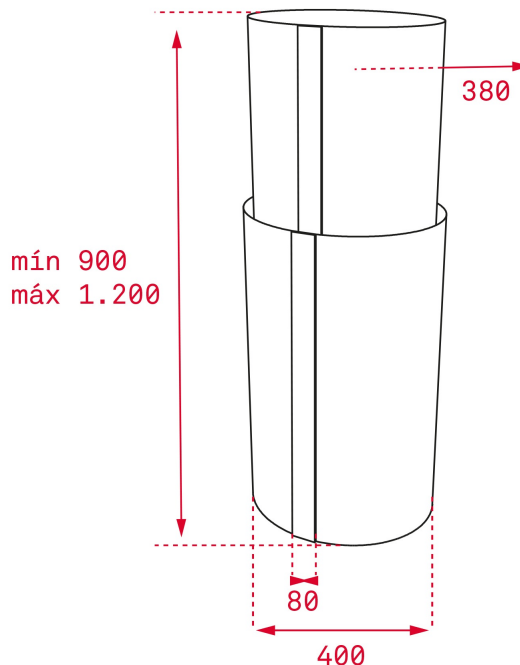

DIMENSIONS

Product height (mm): 900-1200
Product width (mm): 400
Product depth (mm): 400
Product length (mm):
Net weight (Kg): 21,5

TECH SPECS

PARTICULAR CHARACTERISTICS

Certificates: CE; CB
Ø Outlet (mm): 150
Inside light Consumption (W): 3
Plug type: European plug
Power rate (V): 220240
Frequency (Hz): 50
Total hood power (W): 286
Number of motors: 1
Motor power (W): 280

ACCESSORIES

Anti Return valve: Yes
Outlet reduction: Yes
Optional Charcoal Filter: D4C
Conventional recirculation kit (opt) - w/tube cover: SET 1/11

MODELS

Number of filters: 1
Stop delay timer: Yes
Filter saturation indicator: Yes
Number of speeds: 3+1



CC 485 ISLAND

ENERGY LABEL

