

TEKA

DPL 1185 110cm Island Hood with Contour Rim extraction, Touch control and ECOPOWER motor



LED lighting



Rim extraction



Stop delay
timer

DESCRIPTION

110cm Island Hood with Contour Rim extraction, Touch control and ECOPOWER motor

LIFE STYLE

Maestro

COLORS



REFERENCE

REF. 40483172
EAN. 8421152145777

FEATURES

Island hood
Rim extraction
EcoPower motor
Energy Efficiency class: A
Rim extraction
Touch control White display
Operating pilot light
3 speeds + 1 intensive
Exhaust capacities:
Free Outlet, m³/h: 920
Qboost, m³/h: 651
Max., m³/h: 629
Min., m³/h: 331
Noise (LwA) Boost Speed, dB: 65,2
Noise (LwA) Max Speed, dB: 66
Noise (LwA) Min Speed, dB: 54
LED illumination
Reinforced black glass
2 hidden aluminum filters
Stop delay timer
Filter saturation indicator

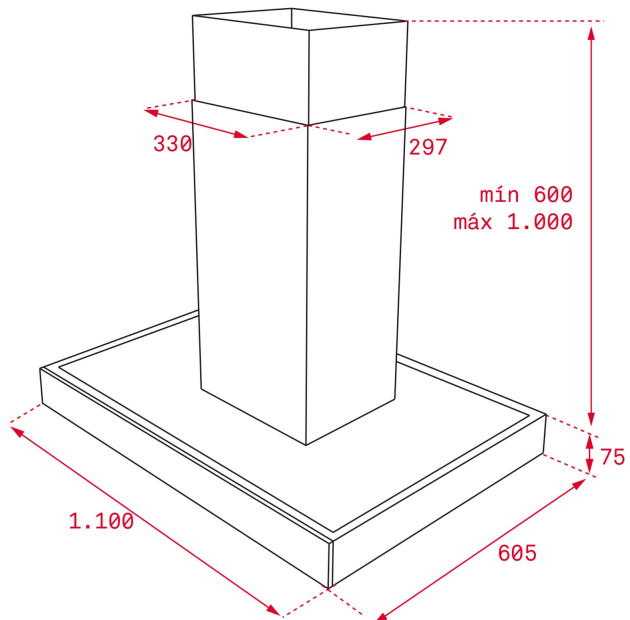

DIMENSIONS

Product height (mm): 817-1117

Product width (mm): 1100

Product depth (mm): 605

Product length (mm):

Net weight (Kg): 17,4

TECH SPECS

FEATURES

Ø Outlet (mm): 150
Inside light Consumption (W): 3
Plug type: European plug
Power rate (V): 220240
Frequency (Hz): 50
Total hood power (W): 292
Number of motors: 1
Motor power (W): 280

ACCESSORIES

Anti Return valve: Yes
Outlet reduction: Yes
Optional Charcoal Filter: D4C
Conventional recirculation kit (opt) - w/tube cover: SET 1/T1

MODELS

Number of filters: 3
Stop delay timer: Yes
Filter saturation indicator: Yes
Number of speeds: 3+1



DPL 1185

ENERGY LABEL

