



GFH 55 55cm Built-in Hood with push buttons control panel and 2 aluminum filters



LED lighting

DESCRIPTION

55cm Built-in Hood with push buttons control panel and 2 aluminum filters

LIFE STYLE

Easy

COLOURS



REFERENCE

REF. 40446700
EAN. 8421152036396



TEKA

GFH 55

FEATURES

Filter group
Push buttons control panel
Operating pilot light
Conventional aspiration
3 speeds
Exhaust capacities:
Free Outlet (m³/h): 367
Max. (m³/h): 329
Min. (m³/h): 223
Noise (LwA) Max Speed 69 dB
Noise (LwA) Min Speed 62 dB
Integrated halogen lamps
2 aluminium filters

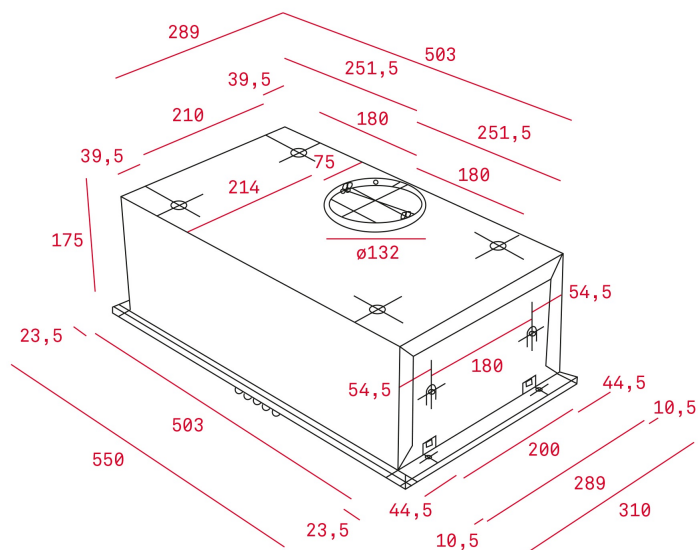

DIMENSIONS

Product height (mm): 175
Product width (mm): 550
Product depth (mm): 310
Product length (mm):
Net weight (Kg): 5,34

TECH SPECS

PARTICULAR CHARACTERISTICS

Type of hood: Integrated
Style: Integrated
Certificates: CE, CB, Rohs
Ø Outlet (mm): 120
Type of inner light: LED
Inside light Consumption (W): 2
Plug type: EU
Power rate (V): 220-240
Frequency (Hz): 50/60
Total hood power (W): 134
Number of motors: 1
Motor power (W): 130
Exhaust Capacity - Free Outlet (m3/h): 367

**EU REGULATION NO. 65/2014
&66/2104**

Annual energy consumption AEC kWh/annum (kWh): 67,9
Energy Efficiency Class: D
Fluid Dynamic Efficiency (FDEhood): 10,5
Fluid Dynamic Efficiency class: E
Light Efficiency (Lehood) lux/Watt: 33,8
Lighting Efficiency class: A

Grease Filtering Efficiency class: C
Air flow (Qmin) m3/h: 296
Air flow (Qmax): 337
Noise (LwA) Min Speed (dB): 62
Noise (LwA) Max Speed (dB): 69
Energy Efficiency Index (EEI): 86,3
Time increase factor: 1,6
Electric power input at best efficiency point (Wbep) W: 111,3
Nominal power of the lighting system (WL) W: 4
Average illumination of the lighting system on the cooking surface (Emiddle) Lux: 135

ACCESSORIES

Anti Return valve: Yes
Outlet extension: yes
Optional Charcoal Filter: C3C
Charcoal filter description: CHARCOAL FILTER C3C

MODELS

Number of filters: 2
Filter description: Aluminium
Control panel: Push buttons
Number of speeds: 3

PRODUCT INFORMATION SHEET - DELEGATED REGULATION (EU) 65/2014

Supplier name or trademark: TEKA
Model identifier: GFH 55
Annual Energy Consumption: 67,9
Energy Efficiency Class: D
Fluid Dynamic Efficiency: 10,5
Fluid Dynamic Efficiency class: E
Lighting Efficiency: 33,8
Lighting Efficiency class: A
Grease Filtering Efficiency:
Grease Filtering Efficiency class: C
Air flow (min speed normal use): 296
Air flow (max speed normal use): 337
Air flow (intensive or boost use):
Airborne acoustical A-weighted sound power emissions (min speed normal use): 62
Airborne acoustical A-weighted sound power emissions (max speed normal use): 69
Airborne acoustical A-weighted sound power emissions (intensive or boost use):
Power consumption in off mode (W):
Power consumption in standby mode (W):



GFH 55

ENERGY LABEL

The image shows a standard European Energy Label for a TEKA GFH 55/GFH 73 unit. The label is rectangular with a blue border and contains the following information:

- Header:** The European Union flag, the word "ENERG" in large letters, and "енергия · енергiя" in smaller letters below it. To the right are two circular icons: one with "Y" and "A" and another with "IE" and "IA".
- Brand and Model:** "TEKA" on the left and "GFH 55/GFH 73" on the right.
- Energy Efficiency Scale:** A vertical bar on the left shows efficiency levels from A++ (top, green) to E (bottom, red). A black arrow points to the "D" level.
- Annual Energy Consumption:** A box on the right contains the number "68" and "kWh/annum" below it.
- Performance Indicators:** Four icons in a row: a fan (labeled "A B C D E F G"), a lightbulb (labeled "A B C D E F G"), water droplets (labeled "A B C D E F G"), and a speaker (labeled "69 dB").
- Footer:** "65/2014" in the bottom left and "1231085-C" in the bottom right.