



# DH2 985 ISLAND 90cm A Decorative Hood with Touch Control display and ECOPOWER motor



A Energy Class



LED lighting



Stop delay timer

**DESCRIPTION**

90cm A Decorative Hood with Touch Control display and ECOPOWER motor

**LIFE STYLE**

Maestro

**COLOURS**



**REFERENCE**

REF. 40484640  
EAN. 8421152145715

**FEATURES**

Island hood  
EcoPower motor  
Energy Efficiency class: A  
Electronic panel  
White display  
Operating pilot light  
3 speeds + 1 intensive  
Exhaust capacities:  
Free Outlet, m<sup>3</sup>/h: 920  
Qboost, m<sup>3</sup>/h: 796  
Max., m<sup>3</sup>/h: 605  
Min., m<sup>3</sup>/h: 311  
Noise (LwA) Boost Speed, dB: 71  
Noise (LwA) Max Speed, dB: 66  
Noise (LwA) Min Speed, dB: 52  
4 LED lamps  
4/3 stainless steel-aluminium filters  
Reinforced Black Glass  
Easy to clean inside panel  
Stop delay timer  
Filter saturation indicator

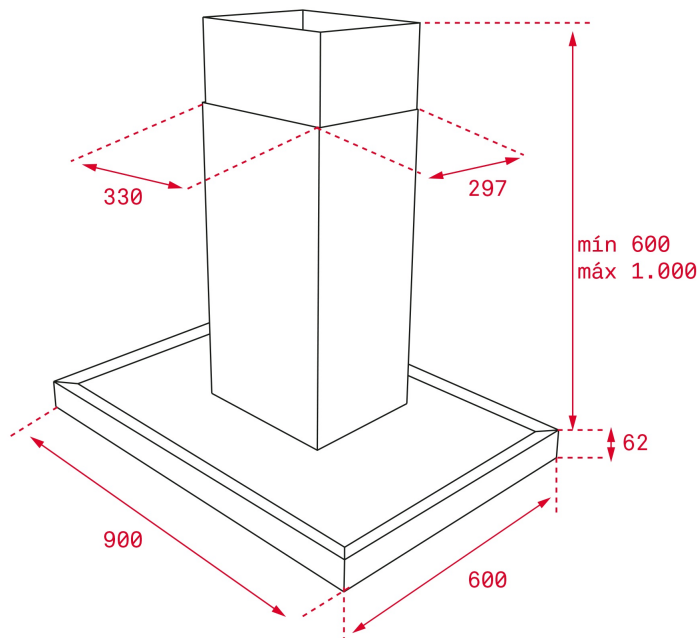

## DIMENSIONS

**Product height (mm):** 817 /  
1117 + 62  
**Product width (mm):** 900  
**Product depth (mm):** 600  
**Product length (mm):**  
**Net weight (Kg):** 36,01

## TECH SPECS

### PARTICULAR CHARACTERISTICS

**Type of hood:** Horizontal  
**Style:** Decoratives  
**Certificates:** CE; CB; Rohs  
**Type of inner light:** LED  
**Inside light Consumption (W):** 3  
**Plug type:** European plug  
**Power rate (V):** 220240  
**Frequency (Hz):** 50  
**Total hood power (W):** 292  
**Number of motors:** 1  
**Motor power (W):** 280  
**Exhaust Capacity - Free Outlet (m3/h):** 920

**EU REGULATION NO. 65/2014  
&66/2104**

**Annual energy consumption AEC kWh/annum (kWh):** 47,8  
**Energy Efficiency Class:** A  
**Fluid Dynamic Efficiency (FDEhood):** 32,3  
**Fluid Dynamic Efficiency class:** A  
**Light Efficiency (Lehood) lux/Watt:** 58,3  
**Lighting Efficiency class:** A  
**Grease Filtering Efficiency class:** C

**Air flow (Qmin) m3/h:** 311  
**Air flow (Qmax):** 605  
**Air flow (Qboost):** 796  
**Noise (LwA) Min Speed (dB):** 52  
**Noise (LwA) Max Speed (dB):** 66  
**Noise (LwA) boost speed (dB):** 71  
**Off mode Power (Po) W:** 0,00  
**Standby Power (Ps) W:** 0,56  
**Energy Efficiency Index (EEI):** 50,1  
**Time increase factor:** 0,8  
**Electric power input at best efficiency point (Wbep) W:** 133,7  
**Nominal power of the lighting system (WL) W:** 12  
**Average illumination of the lighting system on the cooking surface (Emiddle) Lux:** 700

## **ACCESSORIES**

**Anti Return valve:** Yes  
**Outlet reduction:** Yes  
**Optional Charcoal Filter:** D4C  
**Charcoal filter description:** CHARCOAL FILTER D4C  
**Conventional recirculation kit (with tube cover):** 40490149

## **MODELS**

**Number of filters:** 3  
**Filter description:** Stainless Steel filters  
**Control panel:** Backlit electronic control with white display  
**Stop delay timer:** Yes  
**Filter saturation indicator:** Yes  
**Easy-clean inside panel:** Yes  
**Number of speeds:** 3+1



DH2 985 ISLAND

ENERGY LABEL

