



# HSB 615 Four multifonctionnel WISH HSB 615 par Teka



Capacité 70L



HydroClean®



Guide  
télescopique  
Plus

## DESCRIPTIONS

Four multifonctionnel WISH HSB 615 par Teka

## LIFESTYLE

Total

## COULEURS



## RÉFÉRENCE

REF. 41560120  
EAN. 8421152148648

**DESCRIPTION**

Multifonction  
Système de nettoyage HydroClean ECO®  
Email lisse  
Classe énergétique A  
Capacité brute / nette : 71/70 litres  
Bip minutes  
Fonction de préchauffage express automatique  
Fonctions ECO et décongélation  
Double porte vitrée amovible  
Porte intérieure en verre intégral  
1 rail coulissant à ouverture télescopique facile  
Lèchefrite antibasculement et grille renforcée  
Ventilation dynamique  
Plaque The SteamBox et plaque en fonte d'aluminium en option

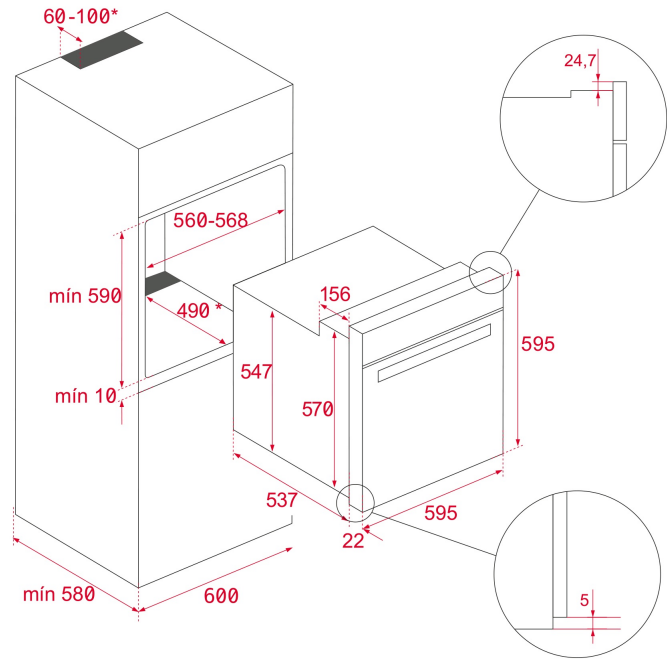

## DIMENSIONS

Hauteur du produit (mm): 595

Largeur du produit (mm): 595

Profondeur du produit (mm):  
537+22

Longueur du produit (mm):

Poids net (kg): 27



HSB 615

LABEL ÉNERGÉTIQUE

The image shows a standard European energy label for a TEKA HSB 615 dishwasher. At the top, it features the EU flag, the word 'ENERG' in large letters, and its translations in Greek (ενέργεια) and Russian (энергия). Below this is the TEKA logo and the model number 'HSB 615'. The central part of the label is a vertical bar with seven colored segments representing energy efficiency classes: A+++ (dark green), A++ (medium green), A+ (light green), A (yellow), B (orange), C (red-orange), and D (red). A black arrow points to the 'A' class. Below the bar, there are two boxes: the first shows a dishwasher icon and '70 L' (volume), and the second shows a cycle icon and '0.71 kWh/cycle\*' (energy consumption). To the right of these boxes, there is another cycle icon and '0.82 kWh/cycle\*' (energy consumption). At the bottom, there is a small line of text in Greek and Russian, and the number '65/2014'.