



**HLF 940 BK** Multifunction oven with 9 cooking functions and HydroClean system. 90cm - XXL capacity



Full extension guides: 100% extraction



77L



HydroClean steam cleaning system



SurroundTemp

**DESCRIPTION**

Multifunction oven with 9 cooking functions and HydroClean system. 90cm - XXL capacity

**COLOURS**



**REFERENCE**

REF. 41592223  
EAN. 8421152155042



**TEKA**

**HLF 940 BK**

**FEATURES**

Multifunction SurroundTemp oven  
9 cooking functions  
Automatic HydroClean system  
Mechanical control knobs  
Electronic timer  
Chrome supports with 5 cooking levels  
Full extension telescopic guides  
Removable triple glazed door  
Children safety lock  
Automatic disconnection safety system  
Manual quick preheating  
Anti-tip deep tray and reinforced grid  
Capacity (gross/net): 91 / 77 litres

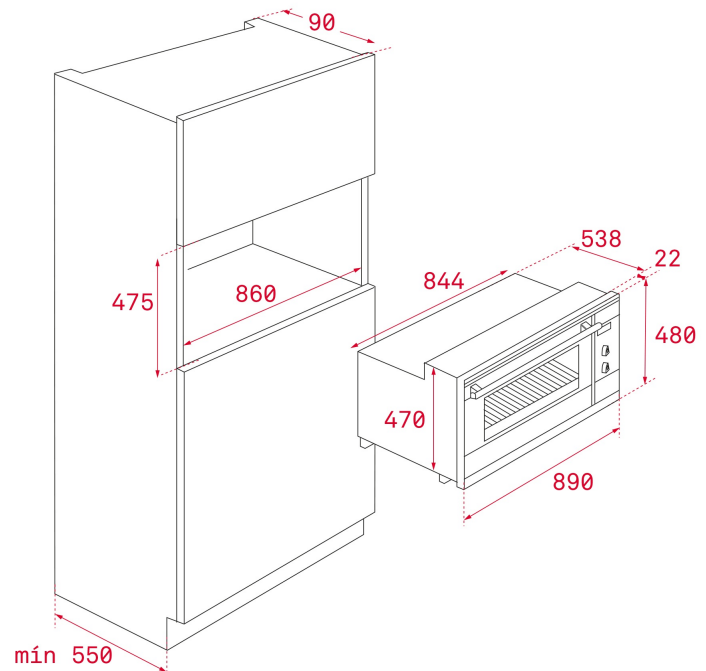

## DIMENSIONS

**Product height (mm):** 480

**Product width (mm):** 890

**Product depth (mm):** 538+22

**Product length (mm):**

**Net weight (Kg):** 51

## TECHNICAL DETAILS

### FEATURES

**Certificates:** N / CE / CCA / CB / GMARK

**Number of cavities:** 1

**Type of inner light:** Halogen

**Inside light position:** SIDE

**Enamelled cavity:** Yes

**Min. Temperature Regulator (°C):** 50

**Max. Temperature Regulator (°C):** 250

**Function selector:** 10+0

**Number of cooking functions:** 9

**Top + Bottom function:** Yes

**Grill + Bottom function:** Yes

**Grill function:** Yes

**MaxiGrill function:** Yes

**Top + Bottom + Fan function:** Yes

**Bottom function:** Yes

**Bottom + TURBO (Pizza) function:** Yes

**Turbo function:** Yes

**Touch Control Programmer:** Yes

**Knobs type:** MMX FIX KNOB knurling

**Removable chromed tray guides:** Yes

**Number of guide levels:** 5

**Full extension telescopic guides:** Yes

## **ELECTRIC CONNECTION**

**Drop-down grill:** Yes  
**Forced refrigeration tangential 1 speed:** Yes

**Maximum Nominal Power (W):** 3551  
**Frequency (Hz):** 50/60  
**Power rate (V):** 220-240  
**Cable Connection Length (cm):** 110  
**Inside light Consumption (W):** 25

## **ENERGY CONSUMPTION**

**Energy consumption per cycle in conventional mode (kWh):** 1.1  
**Energy consumption per cycle in fan-forced convection mode (kWh):** 0,86  
**Bottom Heating Element (W):** 1055  
**Grill (W):** 1700  
**Maxi Grill (W):** 2750  
**Traditional (W):** 2105  
**Turbo (W):** 2400  
**Multifunction Turbo (W):** 30  
**Cooling Fan Motor (W):** 18

## **SAFETY SYSTEMS**

**Automatic disconnection when opening the door:** Yes  
**Panel blocking system:** Yes  
**Children safety block option:** Yes  
**Grill protection:** Yes  
**Anti-tip tray system:** Yes  
**Safety Thermostat:** Yes

## **CLEANING SYSTEM**

**Crystal Clean Enamel (Slippery):** Yes  
**Hydroclean PRO:** Yes

## **ACCESSORIES**

**Baking Tray:** 1  
**Deep Tray (50 mm):** 1  
**Reinforced grid:** 1

## **ENERGY EFFICIENCY**

**Energy Efficiency Class:** A  
**Energy Efficiency Index (EEI):** 98,9



HLF 940 BK

ENERGY LABEL

**ENERG** Y UJ  
енергия · ενέργεια IE IA

**TEKA** HLF 940

A+++  
A++  
A+ **A**  
B  
C  
D

77<sub>L</sub> 1.10 kWh/cycle\*  
0.86 kWh/cycle\*

\* цыклаў - cycles - portion - siklus - პროგრამა - ciclo - tsükkel - ohjelma - ciklus  
ciklus - ciklus - ciklu - siklus - cykl - ciklu - program - cykel

65/2014